



PRODUCT CATALOGUE



WWW.HYVA.COM



Hyva Pacific Catalogue, Edition 1, 01-05-2015

Dear customer,

We are pleased to offer you the first edition of our Hyva Pacific product catalogue which provides you with a representative selection of our comprehensive product range. In order to supply you quickly with our equipment we do keep a range of stock in our warehouse and at our Distributors across Australia and New Zealand.

However should a popular item not be listed in our catalogue please call us and we will provide you with advice and support.

To keep up to date with our evolving product line, Hyva world news items, your nearest Hyva Distributor, visit Hyva Pacific at:

www.hyva.com/au

We also invite you like and follow our Hyva Pacific Facebook page for recent deliveries, specials, news items and related information at:

www.facebook.com/pages/Hyva-Pacific/1450806725177905

I hope this catalogue will help you to select the right equipment in your day to day business.

With kind regards,

André Bremmer
Managing Director

Contents

Page 6

Oil Tanks

- Small steel tanks
- Steel side mounted tanks
- Aluminium side mounted tanks
- Top flange mounted tanks
- Rear mounted tanks
- Oil tank spare parts
- Oil tank accessories
- External return filters

Page 24

Power Take Offs

- PTO's
- PTO accessories

Page 27

Pumps

- Bi – directional Gear pumps
- L/R directional gear pumps
- Piston pumps
- Variable displacement piston pumps
- PTO – Pump adaptors
- Hydro-electric Power Packs

Page 44

Valves

- Tipping valves
- Diverter Valves
- Pressure relief valves
- Hose burst valves
- Multi section valves
- Knock off valves
- Valve accessories

Page 56

Tip Controls

- Proportional tipping controls
- Multi section air switches
- Multi section proportional controls
- Electronic tipping controls
- Tip control accessories

Contents

Page 62

Tipping Cylinders

- Flash hoists – FE (well mount)
- Flash foot-mounts
- Flash hoists – FC (front mount)
- Flash seal kits
- Underbody hoists
- Underbody hoists accessories
- Hyfix body lock
- Polyp grip & slope detector

Page 75

Hoses and Fittings

- Hoses
- Fittings
- Quick release Couplings

Page 80

Towing Hitches & Body Hardware

- King pins
- Pintle-hooks
- Dual purpose hitches
- Tow rings
- V. Orlandi (ringfeeder style) couplings
- Body hardware – Pivot & hinge kits
- Mud flaps & Landing Leg

Page 104

Hyva Lift Skip & Hook Loaders

- Skip loaders
- Hook loaders

Page 115

Ferrari Truck Cranes

- 300 series – T boom up to 3.5tm
- 500 series – Knuckle boom from 2.5tm to 8.0tm
- 700 series – Knuckle boom from 9.5 tm to 50.0tm

Page 124

Hyva Crane Attachments

- Rotators
- Pallet forks
- Grabs & Manipulators

Hyva Oil Tanks

Hyva offers a complete range of state of the art oil tanks, both steel and aluminium. The design of the tanks is fully adapted to the modern trucks and tractors. The available tank supports, straps and profiles make fitting very easy. Our oil tanks are robot welded to secure constant quality. Most tanks are equipped with a 10 micron air breather filter integrated in the filler cap and an oil level indicator. The optional return line filter has a 25 micron filter with an efficiency of 98.7%. To complete your hydraulic kit, Hyva can supply all necessary components related to our hydraulic oil tanks like straps, nuts, tank supports, rubbers, vibration dampers, suction hoses, high pressure hoses, bolts, filler caps, adapters, ball valves and hose pillars (for straight and 90° mounting).

The multifunctional tanks; marked MR are fitted with a covered opening which can accommodate a return filter (Mounting plate- Return filter).

Hyva offers oil tanks for mounting behind the cabin on the chassis (RM), for side mounting (SM) and mounted by a top flange (TM). For each hydraulic system on all types of trucks Hyva has a suitable oil tank, both supplied in steel as well as in aluminium. Hyva tanks are standard equipped with a 1½" BSPOT or 1½" BSPIT suction connection and in general with a Hyva tipping valve mounting plate with a ¾" BSPIT connection.

Steel oil tanks

Side mounted tanks

The SM-range consists of oil tanks with a volume ranging from 12 to 200 litres. SM tanks can be fitted with a return filter when using the Mounting plate-Return filter. In general, the PT-valve can be mounted on the side. To guide the return flow from the tipper valve through the return filter on top of the tank we have created kit L211. This 1¼ inch hose is flexible and can be mounted under the sharp 90 degree corner between valve and filter. The kit is complete with adapters and bonded seals and plug (14799175) to close the tank port on the valve.

Top flange mounted tank

The TM-range consists of oil tanks with a volume ranging from 43 to 85 litres.

Rear mounted tanks (Behind Cab)

The RM-range consists of oil tanks with a volume ranging from 65 to 213 litres.

Aluminium oil tanks

Side mounted tanks

The SM(ALU)-range consists of oil tanks with a volume ranging from 110 to 200 litres. These oil tanks are made of high quality aluminium and are light weight. SM tanks can be fitted with a return filter when using the Mounting plate-Return filter. The PT- valve can be mounted on the side. To guide the return flow from the tipper valve through the return filter on top of the tank we have created kit L211. This 1¼ inch hose is flexible and can be mounted under the sharp 90 degree corner between valve and filter. The kit is complete with adapters, bonded seals and plug (14799175) to close the tank port on the valve.

All tank kits include - tank, filler breather, brackets, straps and return filter

Hydraulic Tanks

In this overview you can find everything about the oil tanks: the coding, the kits and the parts. Also we present you a 'How to order' system, so you can choose your own suitable oil tank and kit in an easy way.

Code system oil tanks

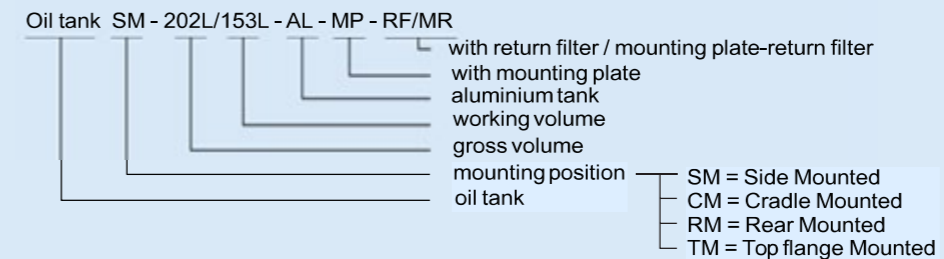

Oil tank RM-252L/213L-MP-RF
Rear mounted tank with 252L total volume and 213L working volume with mounting plate

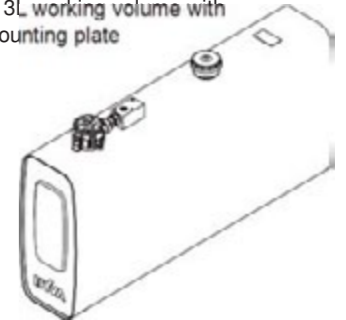

The description of the oil tank is corresponding with the way to choose the correct oil tank. At first the type of tank is chosen, then the gross and working volume. The working volume of the tank must be larger than the gross volume of the cylinder. The material of the tank is the next step. The last two codes explain whether the tank has a valve mounting plate and/or a tank return filter.

Code system oil tank kits

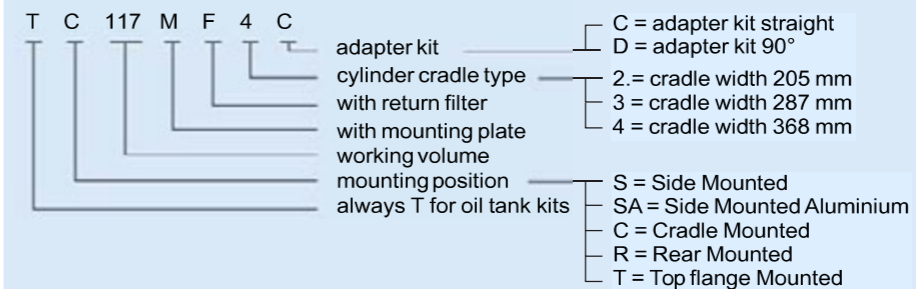

Cradle mounted tank 052L working volume with mounting plate and filter on a FC 149

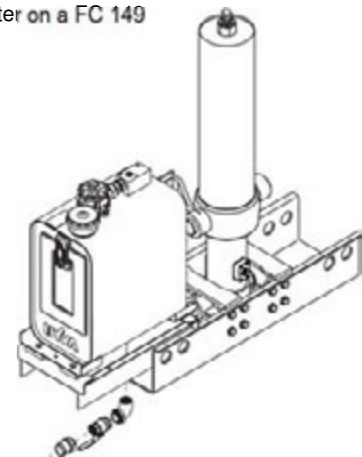

Small Steel Oil Tanks

| Oil tank | Description | Including |
|-----------|-------------------|--------------|
| 14735330H | Oil tank 15 litre | Breather cap |

| | |
|--------------------|--|
| Dims. | L300xW250xH220mm |
| Weight | 12kg |
| Volume | 15L |
| Ports | Inlet: 3/4" F BSP Outlet: 3/4" M BSP |
| Valve mount | Bolts spacing – 50 x 55 (M10) Return – 1/2" F BSP |



| Oil tank | Description | Including |
|-----------|-------------------|--------------|
| 14735335H | Oil tank 26 litre | Breather cap |

| | |
|--------------------|--|
| Dims. | L350xW300xH260mm |
| Weight | 16kg |
| Volume | 26L |
| Ports | Inlet: 3/4" F BSP Outlet: 3/4" M BSP |
| Valve mount | Bolts spacing – 50 x 55 (M10) Return – 1/2" F BSP |

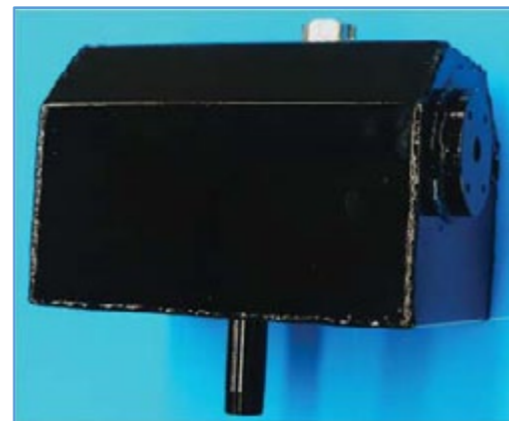

Steel Side Mounted Oil Tanks

TS110M - 110L working volume

| Oil tank | Description | Including |
|----------|--|----------------------|
| TS110M | Oil tank SM-132L/110L-MP-MR single support | Filler cap & support |

*) The weight is including all mounting equipment
Tank kit includes - tank, filler breather, brackets, straps and return filter

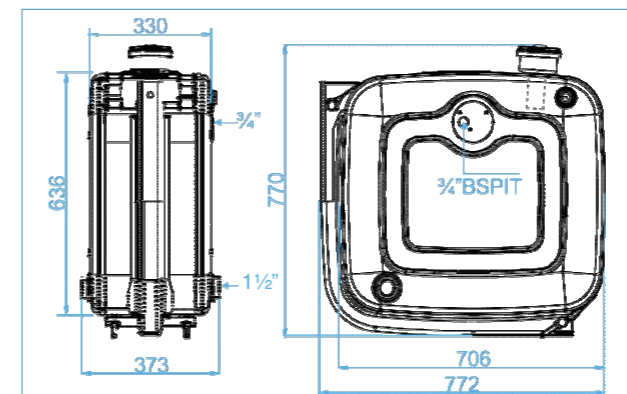

| | |
|--------------------|----------------|
| Weight *) | 46 kg |
| Inlet | 3/4" BSPIT |
| Outlet (2x) | 1 1/2" BSPIT |
| WxHxL | 772x770x373 mm |

TS129MFC - 129L working volume

| Oil tank kit | Oil tank | Description | Mounting equipment incl. Supports, strap & rubbers | Return filter with mounting kit |
|--------------|----------|-----------------------------|--|---------------------------------|
| TS129MFC | 14017206 | Oil tank SM-155L/129L-MP-MR | 14020106 | 14780303 |

*) The weight is including all mounting equipment excluding return filter with mounting kit (=3.2 Kg)

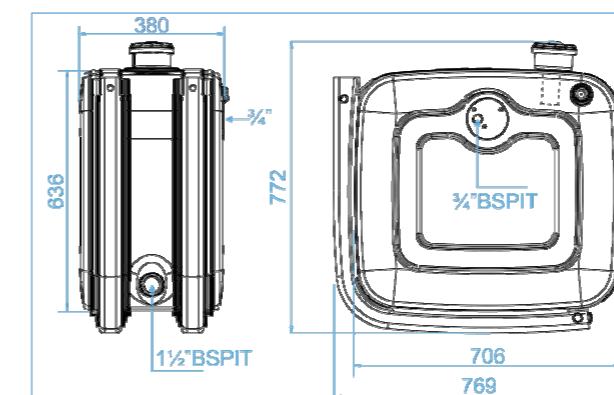

| | |
|------------------|----------------|
| Weight *) | 52 kg |
| Inlet | 3/4" BSPIT |
| Outlet | 1 1/2" BSPIT |
| WxHxL | 706x636x380 mm |

Steel Side Mounted Oil Tanks

TS150MFC - 150L working volume

| Oil tank kit | Oil tank | Description | Mounting equipment incl. Supports, strap & rubbers | Return filter with mounting kit |
|--------------|----------|-----------------------------|--|---------------------------------|
| TS150MFC | 14017208 | Oil tank SM-179L/150L-MP-MR | 14020106 | 14780303 |

*) The weight is including all mounting equipment excluding return filter with mounting kit (=3.2 Kg)

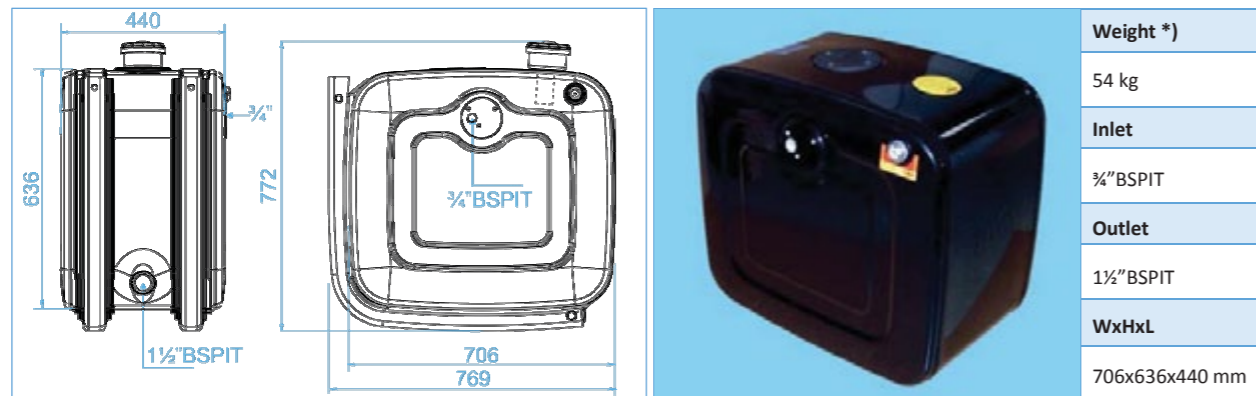

TS170MFC - 170L working volume

| Oil tank kit | Oil tank | Description | Mounting equipment incl. Supports, strap & rubbers | Return filter with mounting kit |
|--------------|----------|-----------------------------|--|---------------------------------|
| TS170MFC | 14017210 | Oil tank SM-201L/170L-MP-MR | 14020106 | 14780303 |

*) The weight is including all mounting equipment excluding return filter with mounting kit (=3.2 Kg)

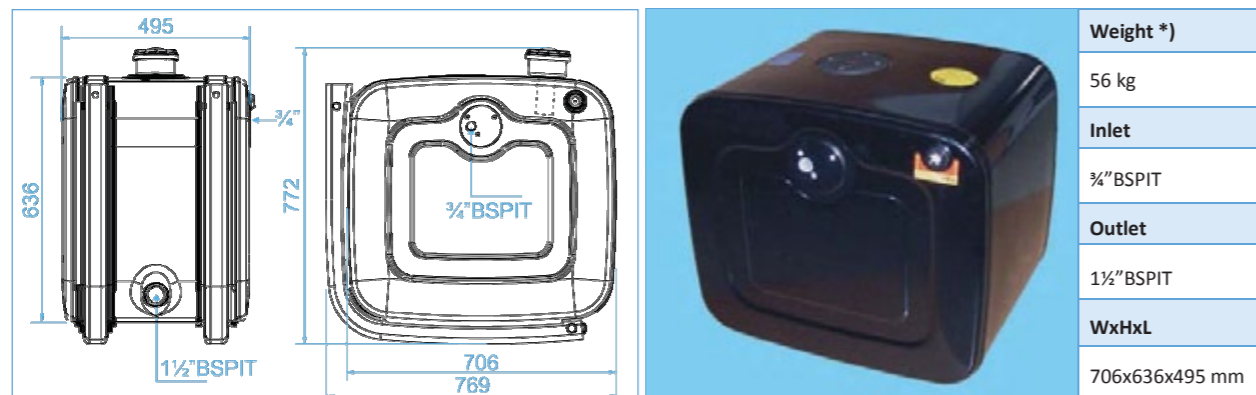

Steel Side Mounted Oil Tanks

TS200MFC - 200L working volume

| Oil tank kit | Oil tank | Description | Mounting equipment incl. Supports, strap & rubbers | Return filter with mounting kit |
|--------------|----------|-----------------------------|--|---------------------------------|
| TS200MFC | 14017232 | Oil tank SM-236L/200L-MP-MR | 14020106 | 14780303 |

*) The weight is including all mounting equipment excluding return filter with mounting kit (=3.2 Kg)

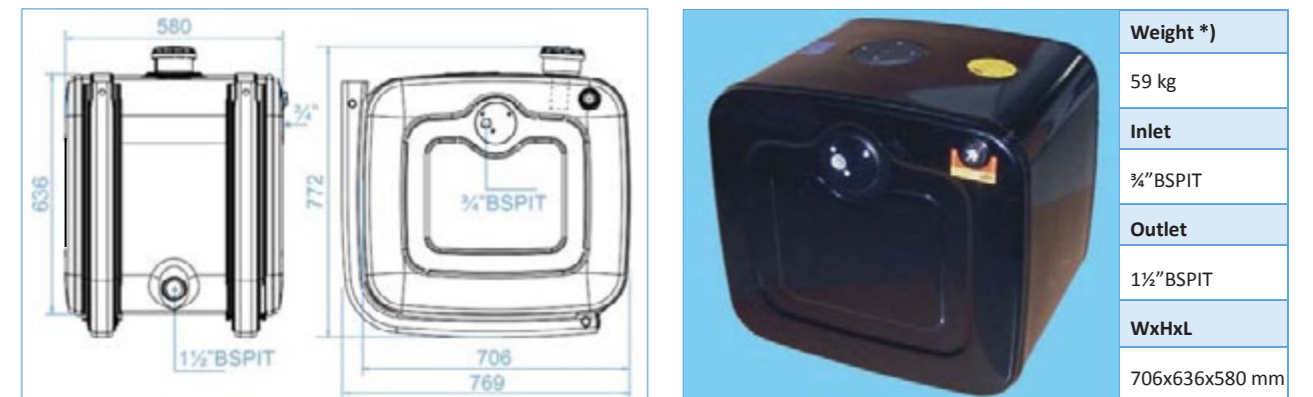

Side Mounted Oil Tank Mounting Kit

| Part No: | Description |
|------------|---|
| 140 20 160 | Mounting equipment for 706x636 SM oil tanks |
| 081 02 116 | Consisting of Air breather filter |
| 140 20 300 | Strap for oil tank 706 x 636 (2x) |
| 140 20 328 | Rubber kit for 2 straps 706 x 636 (1x) |
| 140 20 320 | Tank support for oil tank 706 x 636 (2x) |



Aluminium Side Mounted Oil Tanks

TSA110M - 110L working volume

| Oil tank | Description | Including |
|----------|---|----------------------|
| TSA110M | Oil tank SM-132L/110L-AL-MP-MR single support | Filler cap & support |

The weight is including all mounting equipment
Tank kit includes - tank, filler breather, brackets, straps and return filter



TSA129MFC - 129L working volume

| Oil tank kit | Oil tank | Description | Mounting equipment incl. Supports, strap & rubbers | Return filter with mounting kit |
|--------------|----------|--------------------------------|--|---------------------------------|
| TSA129MFC | 14018226 | Oil tank SM-155L/129L-AL-MP-MR | 14020106 | 14780303 |

*) The weight is including all mounting equipment excluding return filter with mounting kit (=3.2 Kg)

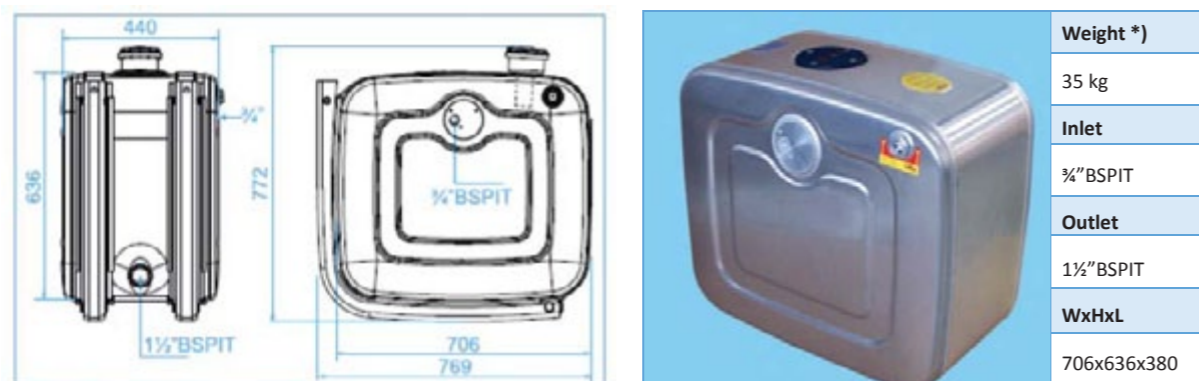

Aluminium Side Mounted Oil Tanks

TSA150MFC - 150L working volume

| Oil tank kit | Oil tank | Description | Mounting equipment incl. Supports, strap & rubbers | Return filter with mounting kit |
|--------------|----------|--------------------------------|--|---------------------------------|
| TSA150MFC | 14018228 | Oil tank SM-179L/150L-AL-MP-MR | 14020106 | 14780303 |

*) The weight is including all mounting equipment excluding return filter with mounting kit (=3.2 Kg)

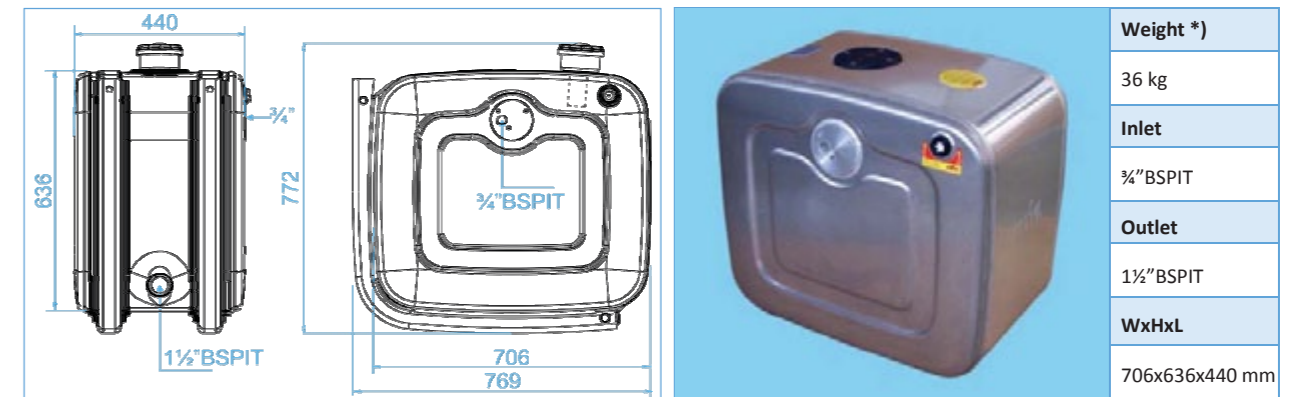

TSA170MFC - 170L working volume

| Oil tank kit | Oil tank | Description | Mounting equipment incl. Supports, strap & rubbers | Return filter with mounting kit |
|--------------|----------|--------------------------------|--|---------------------------------|
| TSA170MFC | 14018230 | Oil tank SM-201L/170L-AL-MP-MR | 14020106 | 14780303 |

*) The weight is including all mounting equipment excluding return filter with mounting kit (=3.2 Kg)

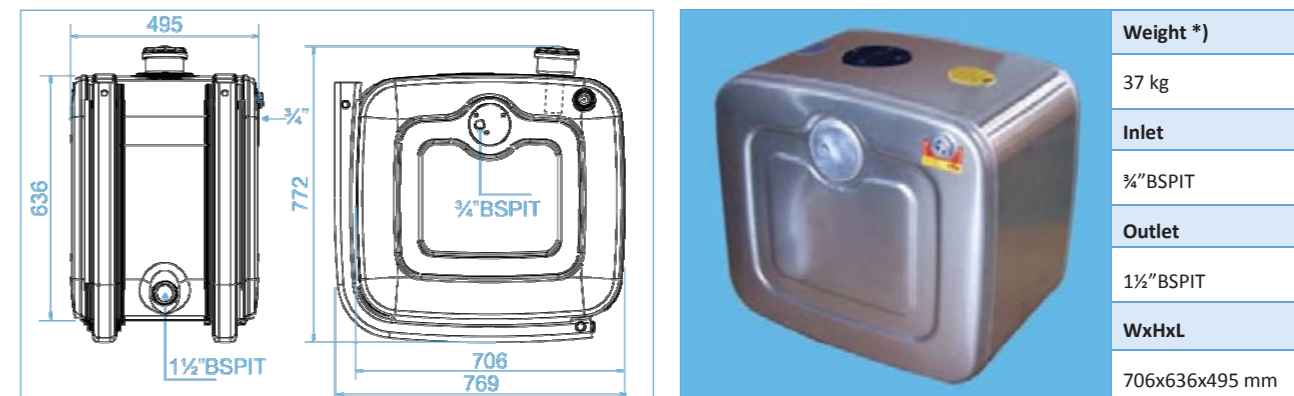

Aluminium Side Mounted Oil Tanks

TSA200MFC - 200L working volume

| Oil tank kit | Oil tank | Description | Mounting equipment incl. Supports, strap & rubbers | Return filter with mounting kit |
|--------------|----------|--------------------------------|--|---------------------------------|
| TSA200MFC | 14018232 | Oil tank SM-236L/200L-AL-MP-MR | 14020106 | 14780303 |

*) The weight is including all mounting equipment excluding return filter with mounting kit (=3.2 Kg)

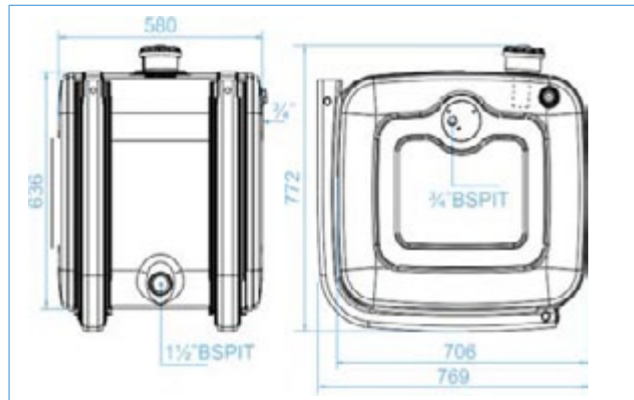

| | |
|------------------|----------------|
| Weight *) | 38 kg |
| Inlet | 1/2" BSPIT |
| Outlet | 1 1/2" BSPIT |
| WxHxL | 706x636x580 mm |

Side Mounted Oil Tank Mounting Kit

| Part No: | Description |
|------------|---|
| 140 20 160 | Mounting equipment for 706x636 SM oil tanks |
| 081 02 116 | Consisting of Air breather filter |
| 140 20 300 | Strap for oil tank 706 x 636 (2x) |
| 140 20 328 | Rubber kit for 2 straps 706 x 636 (1x) |
| 140 20 320 | Tank support for oil tank 706 x 636 (2x) |



Top Flange Mounted Oil Tanks

TT070F Kits - 70L working volume

| Oil tank kit | Oil tank | Description | Filler cap | Vibration damper |
|--------------|----------|--------------------------|------------|------------------|
| Quantities: | 1x | | 1x | 4x |
| TT070F | 14016331 | Oil tank TM-097L/070L-RF | 08102116 | - |
| TT070FC | 14016331 | Oil tank TM-097L/070L-RF | 08102116 | 08101050 |

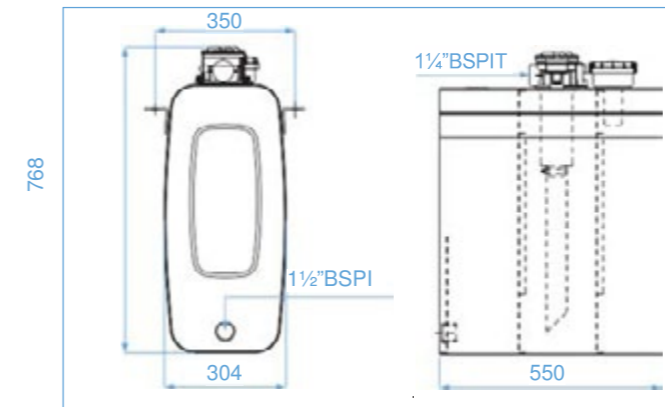

| | |
|---------------|----------------|
| Weight | 38 kg |
| Inlet | 1/4" BSPIT |
| Outlet | 1 1/2" BSPIT |
| WxHxL | 304x674x550 mm |

TT085F Kits - 85L working volume

| Oil tank kit | Oil tank | Description | Filler cap | Vibration damper |
|--------------|----------|--------------------------|------------|------------------|
| Quantities: | 1x | | 1x | 4x |
| TT085F | 14016330 | Oil tank TM-110L/085L-RF | 08102116 | - |
| TT085FC | 14016330 | Oil tank TM-110L/085L-RF | 08102116 | 08101050 |

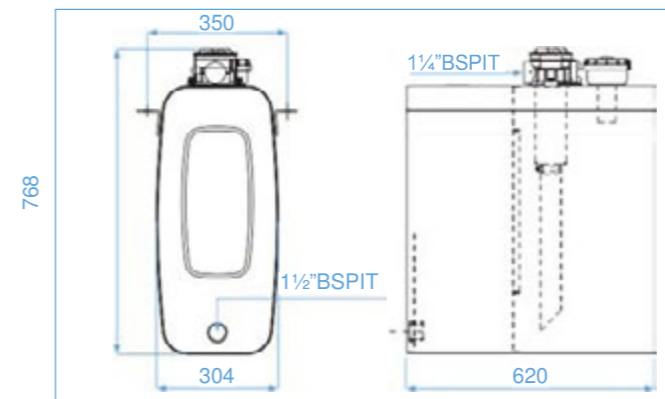

| | |
|---------------|----------------|
| Weight | 38 kg |
| Inlet | 1/4" BSPIT |
| Outlet | 1 1/2" BSPIT |
| WxHxL | 304x674x620 mm |

Rear Mounted Oil Tanks

TR065FC - 65L working volume

| Oil tank kit | Oil tank | Description | Filler cap | Straps | Rubber straps | Tank support | Rubber support | Vibration damper |
|--------------|----------|--------------------------|------------|----------|---------------|--------------|----------------|------------------|
| Quantities: | 1x | | 1x | 2x | 2x | - | - | - |
| TR065FC | 14015220 | Oil tank RM-081L/065L-RF | 08102116 | 14020000 | 14020005 | - | - | - |

*) The weight is including all mounting equipment

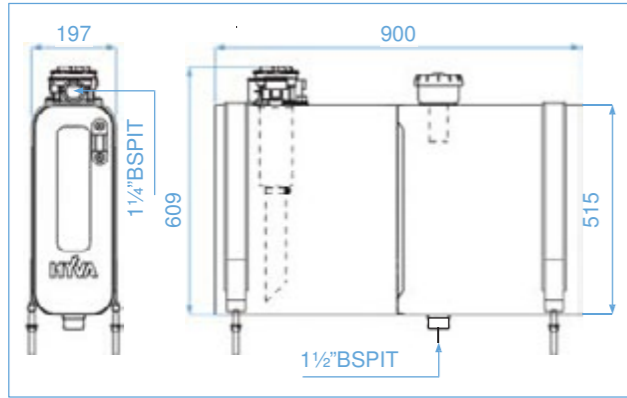

| | |
|-----------|--------------|
| Weight *) | 35 |
| Inlet | 1 1/4" BSPIT |
| Outlet | 1 1/2" BSPIT |
| WxHxL | 190x515x900 |

TR117MC - 117L working volume

| Oil tank kit | Oil tank | Description | Filler cap | Straps | Rubber straps | Tank support | Rubber support | Vibration damper |
|--------------|----------|--------------------------|------------|----------|---------------|--------------|----------------|------------------|
| Quantities: | 1x | | 1x | 2x | 2x | 2x | 2x | 4x |
| TR117MC | 14015240 | Oil tank RM-139L/117L-MP | 08102116 | 14020010 | 14020020 | 14221530 | 14221582 | 08101078 |

*) The weight is including the tank supports (14221530 2x)

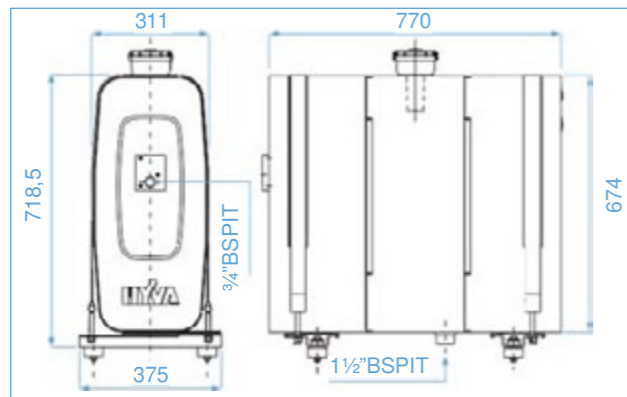

| | |
|-----------|----------------|
| Weight *) | 44.8 kg |
| Inlet | 3/4" BSPIT |
| Outlet | 1 1/2" BSPIT |
| WxHxL | 304x674x770 mm |

Rear Mounted Oil Tanks

TR165MFC - 165L working volume

| Oil tank kit | Oil tank | Description | Filler cap | Straps | Rubber straps | Tank support | Rubber support | Vibration damper |
|--------------|----------|-----------------------------|------------|----------|---------------|--------------|----------------|------------------|
| Quantities: | 1x | | 1x | 2x | 2x | 2x | 2x | 4x |
| TR165MFC | 14015280 | Oil tank RM-195L/165L-MP-RF | 08102116 | 14020010 | 14020020 | 14221530 | 14221582 | 08101078 |

*) The weight is including the tank supports (14221530 2x)

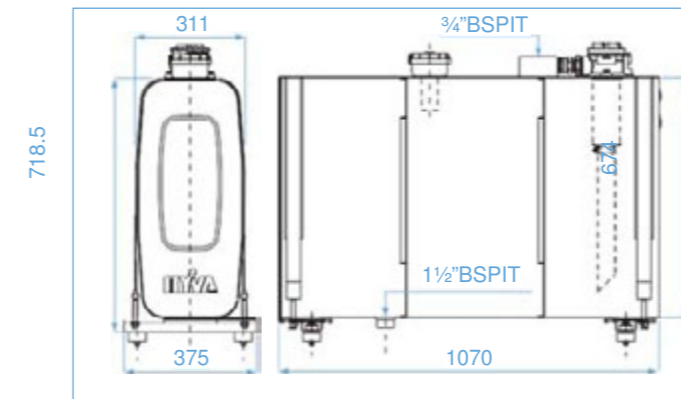

| | |
|-----------|-----------------|
| Weight *) | 56.8 kg |
| Inlet | 3/4" BSPIT |
| Outlet | 1 1/2" BSPIT |
| WxHxL | 304x674x1070 mm |

TR181MC - 181L working volume

| Oil tank kit | Oil tank | Description | Filler cap | Straps | Rubber straps | Tank support | Rubber support | Vibration damper |
|--------------|----------|--------------------------|------------|----------|---------------|--------------|----------------|------------------|
| Quantities: | 1x | | 1x | 2x | 2x | 2x | 2x | 4x |
| TR181MC | 14015265 | Oil tank RM-214L/181L-MP | 08102116 | 14020010 | 14020020 | 14221530 | 14221582 | 08101078 |

*) The weight is including the tank supports (14221530 2x)

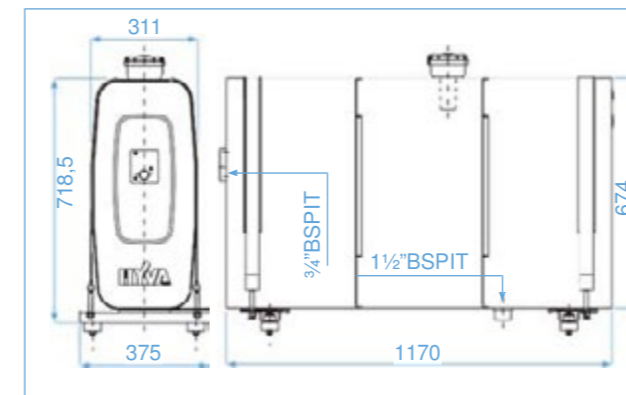

| | |
|-----------|-----------------|
| Weight *) | 57.3 kg |
| Inlet | 3/4" BSPIT |
| Outlet | 1 1/2" BSPIT |
| WxHxL | 304x674x1170 mm |

Rear Mounted Oil Tanks

TR213MFC - 213L working volume

| Oil tank kit | Oil tank | Description | Filler cap | Straps | Rubber straps | Tank support | Rubber support | Vibration damper |
|--------------|----------|-----------------------------|------------|----------|---------------|--------------|----------------|------------------|
| Quantities: | 1x | | 1x | 2x | 2x | 2x | 2x | 4x |
| TR213MFC | 14015300 | Oil tank RM-252L/213L-MP-RF | 08102116 | 14020010 | 14020020 | 14221530 | 14221582 | 08101078 |

*) The weight is including the tank supports (14221530 2x)

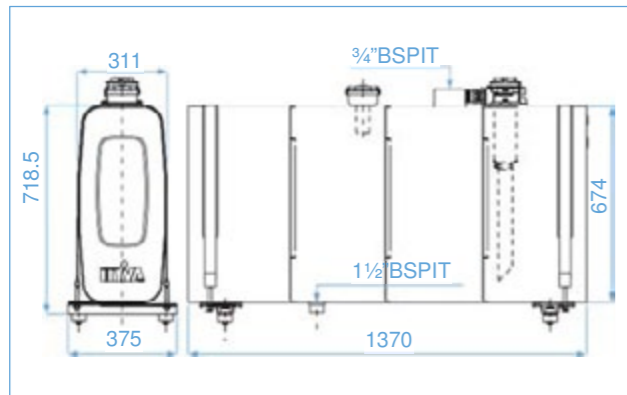

| | |
|------------------|-----------------|
| Weight *) | 64.8 kg |
| Inlet | 3/4" BSPIT |
| Outlet | 1 1/2" BSPIT |
| WxHxL | 304x674x1370 mm |

Rear Mounted Oil Tank Mounting Parts

| Part no. | Description |
|------------|-------------------------------|
| 140 20 000 | Strap for oil tank 140 15 220 |
| 140 20 005 | Rubber for strap 140 15 220 |



| Part no. | Description |
|------------|---|
| 140 20 010 | Strap for oil tank 140 15 (240/265/280/300) |
| 140 20 020 | Rubber for strap 140 15 (240/265/280/300) |



| Part no. | Description |
|------------|------------------------|
| 081 01 078 | Vibration damper round |



| Part no. | Description |
|------------|-------------------------|
| 081 01 050 | Vibration damper square |

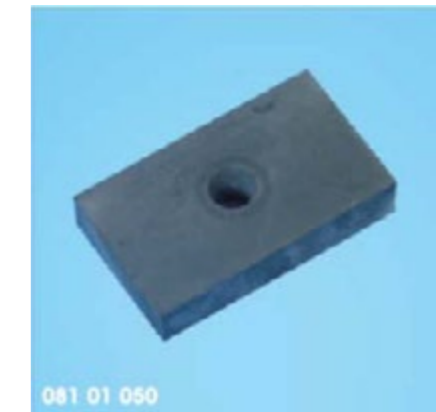

| Part no. | Description |
|------------|---|
| 142 21 530 | Tank support 140 15 (240/265/280/300) |
| 142 21 582 | Rubber for support 140 15 (240/265/280/300) |



Hyva Oil Tank Spare Parts

| Part no. | Description |
|------------|--|
| 081 02 118 | Flange steel for air filter 081 02 116 |
| 081 02 120 | Flange aluminium for air filter 081 02 116 |



| Part no. | Description |
|------------|---|
| 148 95 910 | Flange steel for return filter 147 80 303/306 |
| 148 95 911 | Flange aluminium for return filter 147 80 303/306 |

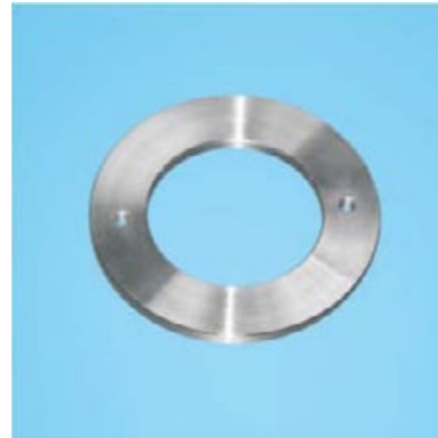

| Part no. | Description |
|------------|-------------|
| 081 02 121 | Spyglass 1" |



| Part no. | Description |
|------------|-----------------|
| 081 02 129 | Level indicator |



| Part no. | Description |
|------------|---------------------------|
| 081 02 201 | Oil filter hose (1 metre) |



| Part no. | Description |
|------------|--|
| 012 38 115 | Hose clamp 1 1/4" - Lp20 for oil filter hose |



Hyva Oil Tank Spare Parts

| 081 02 116 Air Breather Filter Kit | | | |
|------------------------------------|------------|--------------------|------|
| Pos. | Part no. | Description | Qty. |
| A | 081 02 117 | Air filter element | 1 |
| B | 081 02 128 | Sleeve | 1 |
| C | 081 02 119 | Collar | 1 |
| D | 081 02 126 | Seal | 1 |
| E | 081 02 127 | Bolt | 6 |
| F | 081 02 125 | Filter housing | 1 |



| 147 80 303 Return Filter Kit | | | |
|------------------------------|-------------|--------------------|------|
| Pos. | Part no. | Description | Qty. |
| A | 148 96 991A | Oil filter element | 1 |
| B | 148 96 920 | Body | 1 |
| C | 148 96 950 | Seal kit | 1 |
| D | 148 96 905 | Cover | 1 |
| E | 148 96 980 | Spring | 1 |



Accessories for Oil Tanks

| Part no. | Description |
|------------|---|
| 147 80 981 | Ball Valve 1 1/2" BSP Female – Male(with nut) |



| Part no. | Description |
|------------|----------------------------------|
| 147 99 082 | Pipe Elbow 90° 1" BSP (with nut) |



| Part no. | Description |
|----------------|---|
| TNKCAPUC138140 | Tank cap/breather push on Suit 38mm pipe 76mm Cap |



| Part no. | Description |
|-----------|--|
| TNK-TRM12 | Tank cap/breather Screw on 1/2" BSP 47mm Cap |



| Part no. | Description |
|------------|--|
| TNK-TRM234 | Tank cap/breather Screw on 1/4" BSP 76mm Cap |



| Part no. | Description |
|-----------------|---|
| TNK-SES3-10S080 | Tank cap/breather push on Suit 38mm pipe 76mm Cap |



External Return Filters

| Part no. | Description |
|-----------|---|
| FILTEL141 | Small return filter Max. flow 300LPM Press. 12 Bar L=148mm W=96mm |



| Part no. | Description |
|-----------|--|
| FILTHF141 | Small filter housing Ports 3/4" BSP Mount holes M8 Inc Filter L=192mm W=96 |

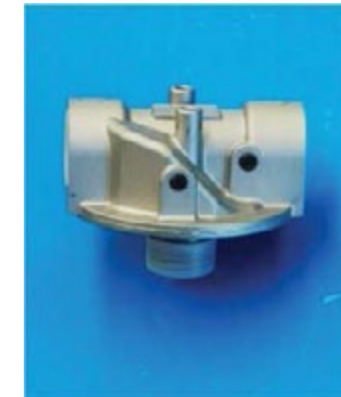

| Part no. | Description |
|-----------|--|
| FILTEL151 | Large return filter Max. flow 300LPM Press. 12 Bar L=182mm W=128mm |



| Part no. | Description |
|-----------|---|
| FILTHF151 | Large filter housing Ports 1 1/4" BSP Mount holes M8 Inc Filter L=249mm W=133mm |



Hyva Power Take Offs

Hyva offers a complete range of PTO's for every common truck gearbox applied worldwide. PTO's are available including mounting kits, adaptor plates, quill shafts, electrical and pneumatic switches and various pump connecting adaptors.

Hyva Pacific has apart from the extensive Hyva range, direct access to all major PTO manufacturers such as OMFB and Hydrocar.

To select the appropriate PTO it is important to provide the following data:

- Truck brand and model
- Gearbox number and ratio
- If a retarder or intarder is fitted
- What the PTO will be used for
 - Pump (provide flow and pressure)
 - Cardan (provide flange type and required power)



Hyva PTO's fit into a modular range. It is possible to combine a PTO, quill shaft and mounting kit to create a kit for multiple gear boxes. For this reason universal PTO's have been developed. By applying this modular system it is possible to keep stock levels low whilst being able to offer a solution for a large quantity of requirements.

Free call 1800 041 733 and talk to Hyva Pacific's experienced team for all your PTO solutions



| Part no. | Description |
|--------------|----------------------|
| PTO02002445H | PTO2000 Eaton 3 Bolt |
| MK02050191H | Mounting kit MK001 |



| Part no. | Description |
|--------------|--------------------|
| PTO02002462H | PTO 1901 Eaton |
| MK02090261H | Mounting kit MK229 |



| Part no. | Description |
|--------------|--------------------|
| PTO02005080H | PTO17A6P Allison |
| MK02051239H | Mounting kit MK322 |



| Part no. | Description |
|--------------|--------------------------|
| PTO02006883H | PTO82Z1P ZF Air MERIT |
| MK02051597H | Mounting kit MK711 |
| MK02050346H | Mounting kit MK354 |
| 02090857H | Quill shaft ADK540 |
| 02007121H | Merit switch wiring loom |



| Part no. | Description |
|--------------|-----------------------------|
| PTO021208005 | PTO Mitsubishi M038 Elec 3H |
| MK021458001 | Mounting kit PTO0121208005 |





| Part no. | Description |
|--------------|--------------------|
| PTO02002458H | PTO 1900 Fuller |
| MK02090261H | Mounting kit MK229 |



| Part no. | Description |
|--------------|------------------------------|
| PTO02005095H | PTO 17E6P Eaton 4 Bolt 400nm |
| MK02050351H | Mounting kit MK383 |



| Part no. | Description |
|--------------|---------------------|
| PTO021204070 | PTO Isuzu Air MZW6P |
| MK021454000 | Mounting kit MZW6P |



| Part no. | Description |
|--------------|---------------------|
| PTO02006710H | PTO 81V1P Volvo Air |
| MK02051599H | Mounting kit MK713 |



| Part no. | Description |
|--------------|------------------------|
| PTO021204050 | PTO Electric Isuzu MYY |
| MK021465005 | Mounting kit Isuzu MYY |
| 021417200 | Switch kit 24V PTO |

Hyva Pumps

Hyva offers a complete range of gear and piston pumps with a displacement of 20 until 150 l/min and a working pressure up to 350 bar to suit every application.

The Pressure that matters in application of pumps are:

- **Max continuous pressure** – pressure allowed constantly, without peaks
- **Max intermittent pressure** – pressure allowed for maximum 20 seconds
- **Max peak pressure** – pressure allowed for a short interval of Max 8 seconds

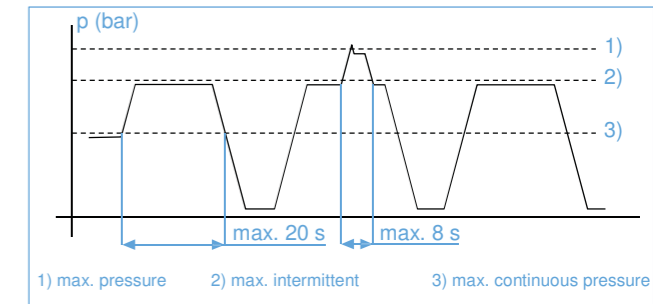

In the following tables the Max continuous pressure is given as working pressure.

For tippers we generally use Max continuous pressure as the tipping cycle does not require max pressure for long intervals.

For truck loader cranes, hook loaders, skip loaders and moving floors, we advise to use heavy duty gear pumps or piston pumps.

Piston pumps require extra attention when it comes to suction characteristics. Rotation frequency (RF) should not be too high as this negativity influences the suction performance of the pump, especially when the pump is mounted above the suction connection to the oil supply, i.e. engine mounted piston pump with a side mounted tank. Max self-priming speed (MSPS) is the speed allowed for which the pump suction still performs well, with pump fitted above tank level. Max rotation frequency, allowed with the pump below tank.

Besides the standard hyva pump range listed Hyva offers a number of special pumps for truck applications.

- *Special gear and piston pumps on request
- *Piston Pumps for engine PTO with bypass valve
- *Double pumps
- *Pumps by third parties like Parker and sun-fab
- *Double piston pumps
- *Pump Elongation adaptors

Code hydraulic pumps

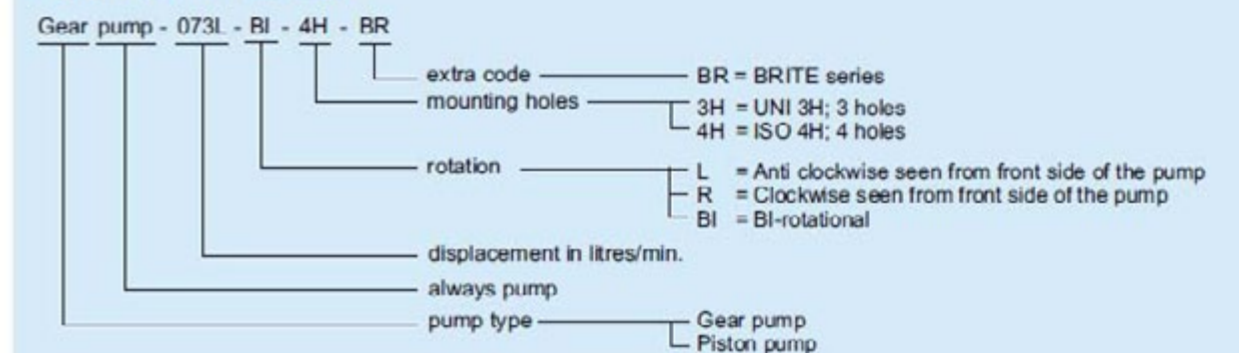

Gear Pumps UNI 3H: BI-Rotational

FP200 Series

The smallest pumps in the hyva range, the FP200 series is suitable for small tippers with underbody hoists, truck loader cranes, tilt trays and other low flow, high pressure applications.

| Part no. | Description | Displacement | Weight | Suction side | Press side | Rotation Frequency | work press | Max Inter. Press | Max Peak Press |
|------------|--|--------------------|--------|--------------|------------|--------------------|------------|------------------|----------------|
| 145 63 028 | Gear pump 020L-BI-3H | 20 cm ³ | 6,3 kg | G½" | G½" | 2000 | 260 bar | 280 bar | 290 bar |
| 145 63 033 | Gear pump 025L-BI-3H | 25 cm ³ | 6,8 kg | G¾" | G¾" | 2000 | 220 bar | 250 bar | 260 bar |
| 145 63 043 | Gear pump 032L-BI-3H | 32 cm ³ | 7,2 kg | G¾" | G¾" | 1800 | 190 bar | 210 bar | 220 bar |
| 02460055 | Seal kit FP200 series | | | | | | | | |
| 02050015H | PTO – Pump adaptor kit 6 spline to 13 spline | | | | | | | | |

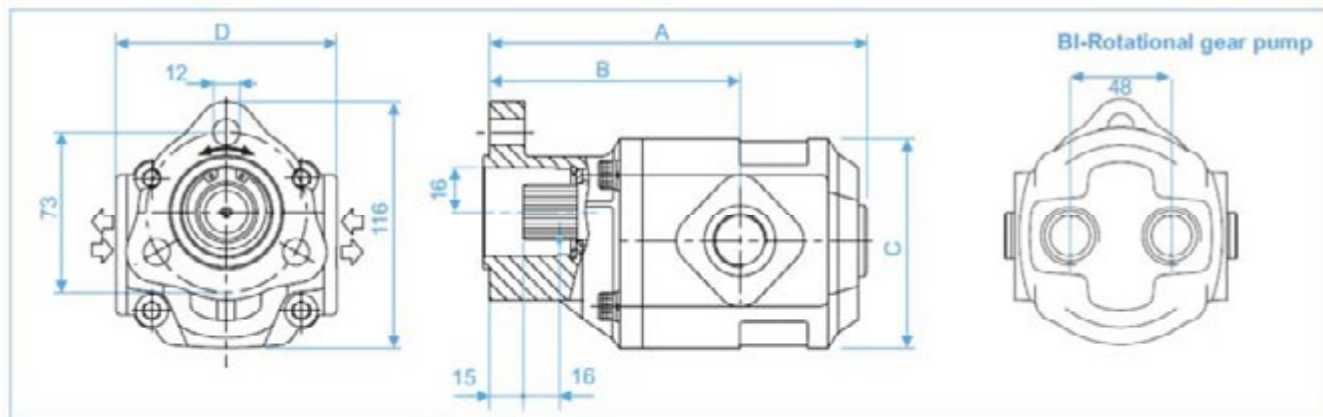

| Part no. | Description | A | B | C | D |
|------------|----------------------|-----|-----|-----|-----|
| 145 63 028 | Gear pump 020L-BI-3H | 157 | 119 | 102 | 100 |
| 145 63 033 | Gear pump 025L-BI-3H | 160 | 112 | 102 | 100 |
| 145 63 043 | Gear pump 032L-BI-3H | 175 | 122 | 102 | 100 |



Gear Pumps UNI 3H: BI-Rotational

Brite Series

The Brite series pumps have a higher working pressure and longer cycle time than the standard gear pumps. These quality pumps have the convenience of both side and rear mounting of the hoses, and are maintenance free with no standstill.

| Part no. | Description | Displacement | Weight | Suction side | Press side | Rotation Frequency | work press | Max Inter. Press | Max Peak Press |
|------------|---|---------------------|---------|--------------|------------|--------------------|------------|------------------|----------------|
| 145 63 034 | Gear pump 035L-BI-3H | 34.5cm ³ | 12kg | G¾" | G¾" | 2500 | 280 bar | 300 bar | 310 bar |
| 145 63 052 | Gear pump 052L-BI-3H | 52 cm ³ | 13kg | G1" | G1" | 2500 | 250 bar | 270 bar | 280 bar |
| 145 63 061 | Gear pump 061L-BI-3H | 61 cm ³ | 13,5 kg | G1" | G1" | 2500 | 230 bar | 250 bar | 260 bar |
| 145 63 082 | Gear pump 082L-BI-3H | 82 cm ³ | 15,5 kg | G1" | G1" | 2500 | 195 bar | 225 bar | 230 bar |
| 02460000 | Seal kit Brite pump 082L | | | | | | | | |
| 02460067 | Seal kit Brite pump 035L – 061L | | | | | | | | |
| 02050020H | PTO – Pump adaptor kit 6 spline to 6 spline | | | | | | | | |

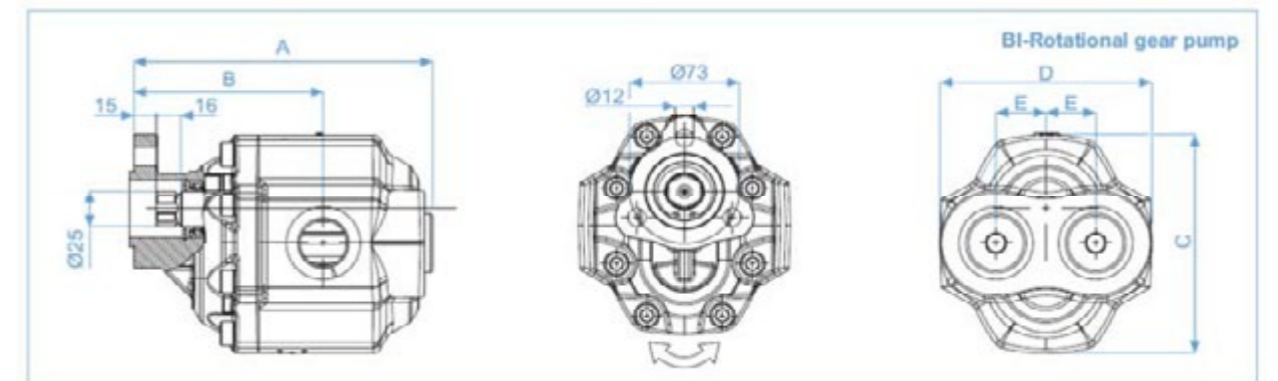

| Part no. | Description | A | B | C | D | E |
|------------|----------------------|-----|-----|-----|-----|----|
| 145 63 034 | Gear pump 035L-BI-3H | 168 | 110 | 149 | 128 | 30 |
| 145 63 052 | Gear pump 052L-BI-3H | 179 | 112 | 149 | 128 | 30 |
| 145 63 061 | Gear pump 061L-BI-3H | 185 | 118 | 149 | 128 | 30 |
| 145 63 082 | Gear pump 082L-BI-3H | 198 | 126 | 149 | 140 | 30 |



Gear Pumps UNI 3H: BI-Rotational

APL Series

The standard tipping pump, this range is primarily designed for medium to large tippers, and they have the ability for bi directional operation without having to dis-assemble and modify.

| Part no. | Description | Displacement | Weight | Suction side | Press side | Rotation Frequency | work press | Max Inter. Press | Max Peak Press |
|------------|---|---------------------|---------|--------------|------------|--------------------|------------|------------------|----------------|
| 145 63 105 | Gear pump 061L-BI-3H | 61 cm ³ | 10.7 kg | G1" | G1" | 1750 | 180 bar | 200 bar | 230 bar |
| 145 63 405 | Gear pump 082L-BI-3H | 82 cm ³ | 11 kg | G1" | G1" | 1500 | 160 bar | 180 bar | 220 bar |
| 145 63 115 | Gear pump 100L-BI-3H | 100 cm ³ | 11.5kg | G1" | G1" | 1500 | 160 bar | 180 bar | 210 bar |
| 145 63 120 | Gear pump 125L-BI-3H | 125 cm ³ | 12.3 kg | G1" | G1" | 1500 | 140 bar | 160 bar | 200 bar |
| 02470840 | Seal kit APL series | | | | | | | | |
| 02050020H | PTO – Pump adaptor kit 6 spline to 6 spline | | | | | | | | |

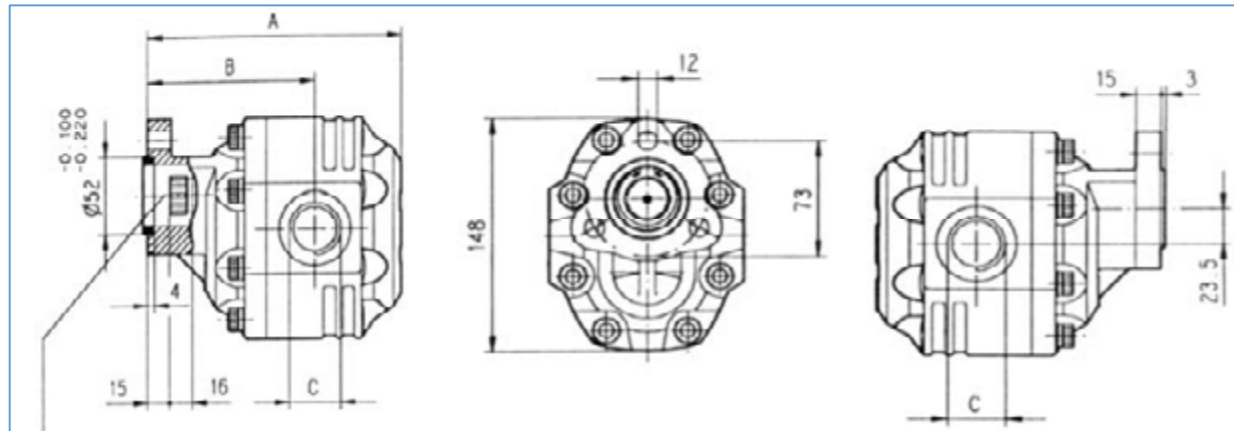

| Part no. | Description | A | B |
|------------|----------------------|-------|-------|
| 145 63 105 | Gear pump 061L-BI-3H | 178.5 | 166.5 |
| 145 63 405 | Gear pump 082L-BI-3H | 191.5 | 122.5 |
| 145 63 115 | Gear pump 100L-BI-3H | 218 | 136 |
| 145 63 120 | Gear pump 125L-BI-3H | 234 | 152 |



Gear pumps UNI 3H: Left or Right rotational

FP 300 Series

This series of pump had a dedicated rotation. They are heavy duty with high cycle time and high working pressure.

| Part no. | Description | Displacement | Weight | Suction side | Press side | Rotation Frequency | work press | Max Inter. Press | Max Peak Press |
|------------|---|----------------------|--------|-------------------|-------------------|--------------------|------------|------------------|----------------|
| 145 63 170 | Gear pump 27L-L-3H | 26 cm ³ | 9,8 kg | G $\frac{3}{4}$ " | G $\frac{3}{4}$ " | 3000 | 290 bar | 315 bar | 325 bar |
| 145 63 180 | Gear pump 27L-R-3H | 26 cm ³ | 9,8 kg | G $\frac{3}{4}$ " | G $\frac{3}{4}$ " | 3000 | 290 bar | 315 bar | 325 bar |
| 145 63 210 | Gear pump 43L-L-3H | 43.7 cm ³ | 11.9kg | G $\frac{3}{4}$ " | G $\frac{3}{4}$ " | 2500 | 270 bar | 290 bar | 300 bar |
| 145 63 220 | Gear pump 43L-R-3H | 43.7 cm ³ | 11.9kg | G $\frac{3}{4}$ " | G $\frac{3}{4}$ " | 2500 | 270 bar | 290 bar | 300 bar |
| 02460060 | Seal kit FP 300 series | | | | | | | | |
| 02050020H | PTO – Pump adaptor kit 6 spline to 6 spline | | | | | | | | |

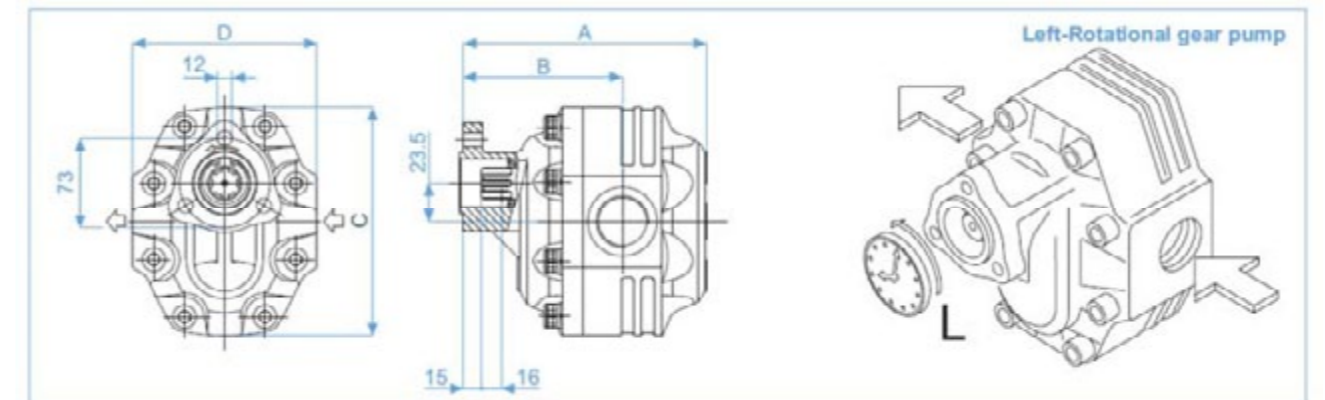

| Part no. | Description | A | B | C | D |
|------------|--------------------|-------|-------|-----|-----|
| 145 63 170 | Gear pump 27L-L-3H | 157 | 107 | 148 | 120 |
| 145 63 180 | Gear pump 27L-R-3H | 157 | 107 | 148 | 120 |
| 145 63 210 | Gear pump 43L-L-3H | 166.5 | 112.5 | 148 | 120 |
| 145 63 220 | Gear pump 43L-R-3H | 166.5 | 112.5 | 148 | 120 |



Gear pumps UNI 3H: Left or Right rotational

FP 400 Series

This series of pump had a dedicated rotation. They are a heavy duty pump with a high cycle time and high working pressure.

| Part no. | Description | Displacement | Weight | Suction side | Press side | Rotation Frequency | work press | Max Inter. Press | Max Peak Press |
|------------|---|---------------------|--------|--------------|------------|--------------------|------------|------------------|----------------|
| 145 63 262 | Gear pump 63L-L-3H | 63 cm ³ | 18.4kg | G1" | G¾" | 2700 | 290 bar | 315 bar | 325 bar |
| 145 63 264 | Gear pump 63L-R-3H | | | | | | | | |
| 145 63 310 | Gear pump 87L-L-3H | 86 cm ³ | 21.5kg | G1¼" | G1" | 2700 | 260 bar | 280 bar | 290 bar |
| 145 63 320 | Gear pump 87L-R-3H | | | | | | | | |
| 145 63 330 | Gear pump 109L-L-3H | 108 cm ³ | 22.5kg | G1¼" | G1" | 2700 | 240 bar | 260 bar | 280 bar |
| 145 63 340 | Gear pump 109L-R-3H | | | | | | | | |
| 145 63 350 | Gear pump 133L-L-3H | 133 cm ³ | 22.6kg | G1½" | G1" | 2500 | 220 bar | 250 bar | 260 bar |
| 145 63 360 | Gear pump 133L-R-3H | | | | | | | | |
| 145 63 370 | Gear pump 150L-L-3H | 150 cm ³ | 23.5kg | G1½" | G1" | 2500 | 180 bar | 200 bar | 220 bar |
| 02460070 | Seal kit FP 400 series | | | | | | | | |
| 02050020H | PTO – Pump adaptor kit 6 spline to 6 spline | | | | | | | | |

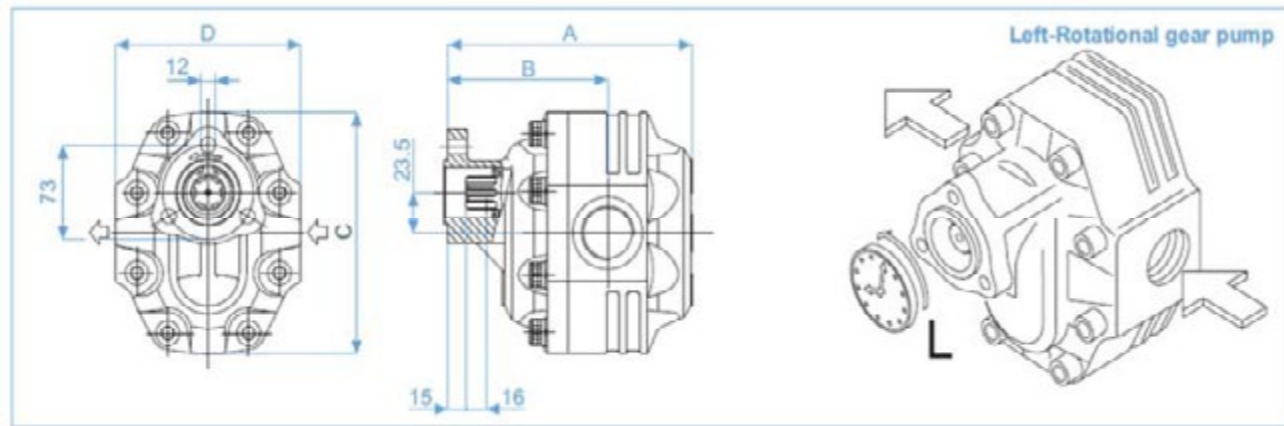

| Part no. | Description | A | B | C | D |
|------------|----------------------------|-------|-------|-----|-----|
| 145 63 262 | Gear pump 63L-(L or R)-3H | 187.5 | 119.5 | 185 | 150 |
| 145 63 264 | | | | | |
| 145 63 310 | Gear pump 87L-(L or R)-3H | 196.5 | 128.5 | 185 | 150 |
| 145 63 320 | | | | | |
| 145 63 330 | Gear pump 109L-(L or R)-3H | 204.5 | 129.5 | 185 | 150 |
| 145 63 340 | | | | | |
| 145 63 350 | Gear pump 133L-(L or R)-3H | 219.5 | 144.5 | 185 | 150 |
| 145 63 360 | | | | | |
| 145 63 370 | Gear pump 150L-L-3H | 223.5 | 150 | 185 | 150 |



Gear Pumps ISO 4H: Bi-Rotational

Brite Series

The Brite series pumps have a higher working pressure and longer cycle time than the standard gear pumps. These quality pumps have the convenience of both side and rear mounting of the hoses, and are maintenance free with no standstill.

| Part no. | Description | Displacement | Weight | Suction side | Press side | Rotation Frequency | work press | Max Inter. Press | Max Peak Press |
|------------|-------------------------------|---------------------|---------|--------------|------------|--------------------|------------|------------------|----------------|
| 145 62 005 | Gear pump 035L-BI-4H-BR | 35 cm ³ | 10.7 kg | G¾" | G¾" | 2500 | 230 bar | 250 bar | 260 bar |
| 145 62 010 | Gear pump 052L-BI-4H-BR | 52 cm ³ | 13.5 kg | G1" | G1" | 2500 | 230 bar | 275 bar | 275 bar |
| 145 62 015 | Gear pump 061L-BI-4H-BR | 61 cm ³ | 14.1 kg | G1" | G1" | 2500 | 230 bar | 250 bar | 260 bar |
| 145 62 020 | Gear pump 073L-BI-4H-BR | 73 cm ³ | 15.1 kg | G1" | G1" | 2500 | 205 bar | 225 bar | 230 bar |
| 145 62 025 | Gear pump 082L-BI-4H-BR | 82 cm ³ | 16.1 kg | G1" | G1" | 2500 | 205 bar | 225 bar | 230 bar |
| 145 62 030 | Gear pump 092L-BI-4H-BR | 92 cm ³ | 19.8 kg | G1¼" | G1¼" | 2250 | 205 bar | 265 bar | 265 bar |
| 145 62 035 | Gear pump 113L-BI-4H-BR | 113 cm ³ | 20.5 kg | G1¼" | G1¼" | 2250 | 205 bar | 225 bar | 230 bar |
| 02460000 | Seal kit 4 hole brite 52 – 82 | | | | | | | | |
| 02460005 | Seal kit 4hole brite 92 – 113 | | | | | | | | |

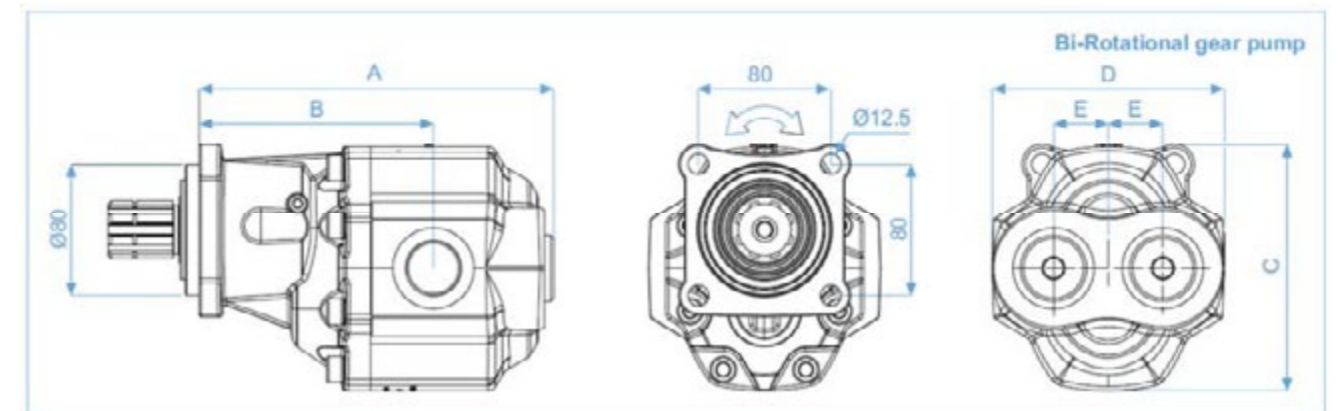

| Part no. | Description | A | B | C | D | E |
|------------|-------------------------|-----|-----|-----|-----|----|
| 145 62 005 | Gear pump 035L-BI-4H-BR | 189 | 131 | 149 | 128 | 30 |
| 145 62 010 | Gear pump 052L-BI-4H-BR | 200 | 133 | 149 | 128 | 30 |
| 145 62 015 | Gear pump 061L-BI-4H-BR | 206 | 139 | 149 | 128 | 30 |
| 145 62 020 | Gear pump 073L-BI-4H-BR | 214 | 142 | 149 | 140 | 33 |
| 145 62 025 | Gear pump 082L-BI-4H-BR | 218 | 147 | 149 | 140 | 33 |
| 145 62 030 | Gear pump 092L-BI-4H-BR | 236 | 156 | 166 | 141 | 33 |
| 145 62 035 | Gear pump 113L-BI-4H-BR | 246 | 166 | 166 | 141 | 33 |



Piston Pumps Hyva ISO 4H: Left or Right rotational

| Part no. | Description | Displacement | Weight | Suction side | Suction adapter | Press. side | Press. adapter | RF/MSPS | Work Press. | Max Int Press. |
|------------|--------------------------|---------------------|--------|--------------|-----------------|-------------|----------------|-----------|-------------|----------------|
| 145 64 600 | Piston pump 040L-R-4H | 40 cm ³ | 12kg | G1" | 1 3/4" | G 3/4" | 3/4" | 2500/1850 | 280 bar | 350 bar |
| 145 64 605 | Piston pump 040L-L-4H | | | | | | | | | |
| 145 64 610 | Piston pump 050L-R-4H | 50 cm ³ | 12kg | G1" | 1 3/4" | G 3/4" | 3/4" | 2400/1700 | 280 bar | 350 bar |
| 145 64 615 | Piston pump 050L-L-4H | | | | | | | | | |
| 145 64 620 | Piston pump 063L-R-4H | 63 cm ³ | 12kg | G1" | 1 3/4" | G 3/4" | 3/4" | 2200/1600 | 280 bar | 350 bar |
| 145 64 625 | Piston pump 063L-L-4H | | | | | | | | | |
| 145 64 630 | Piston pump 080L-R-4H | 80 cm ³ | 12kg | G1" | 1 3/4" | G 3/4" | 1" | 2000/1300 | 240 bar | 315 bar |
| 145 64 635 | Piston pump 080L-L-4H | | | | | | | | | |
| 145 64 640 | Piston pump 080L-HP-R-4H | 80 cm ³ | 16kg | G1 1/4" | 1 3/4" | G1" | 1" | 2200/1300 | 280 bar | 350 bar |
| 145 64 645 | Piston pump 080L-HP-L-4H | | | | | | | | | |
| 145 64 700 | Piston pump 110L-HP-R-4H | 110 cm ³ | 17kg | G1 1/4" | 2" | G1" | 1" | 2000/1300 | 300 bar | 350 bar |
| 145 64 705 | Piston pump 110L-HP-L-4H | | | | | | | | | |

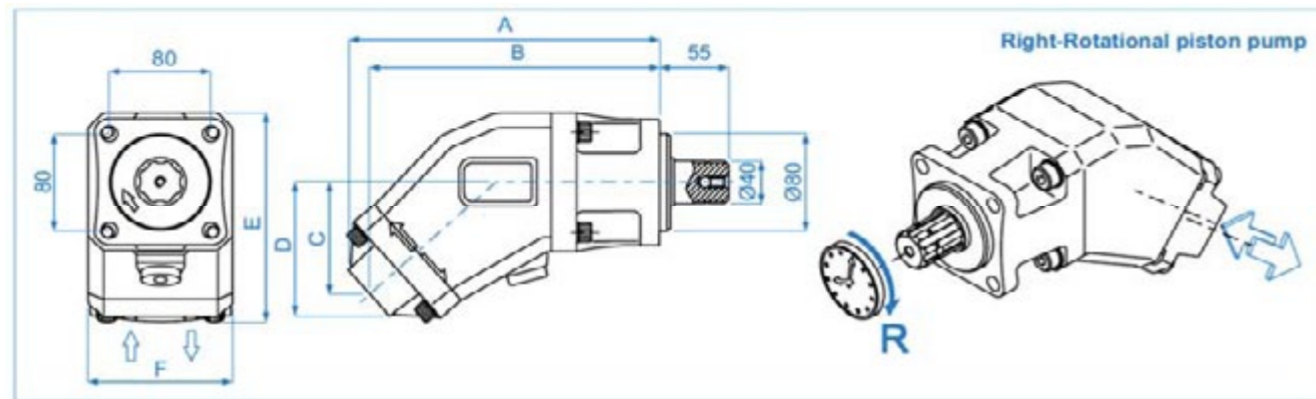

| Part no. | Description | A | B | C | D | E | F |
|------------|--------------------------|-----|-----|-----|-----|-----|-----|
| 145 64 600 | Piston pump 040L-R-4H | 244 | 228 | 91 | 110 | 173 | 116 |
| 145 64 605 | Piston pump 040L-L-4H | 244 | 228 | 91 | 110 | 173 | 116 |
| 145 64 610 | Piston pump 050L-R-4H | 244 | 228 | 91 | 110 | 173 | 116 |
| 145 64 615 | Piston pump 050L-L-4H | 244 | 228 | 91 | 110 | 173 | 116 |
| 145 64 620 | Piston pump 063L-R-4H | 244 | 228 | 91 | 110 | 173 | 116 |
| 145 64 625 | Piston pump 063L-L-4H | 244 | 228 | 91 | 110 | 173 | 116 |
| 145 64 630 | Piston pump 080L-R-4H | 244 | 228 | 91 | 110 | 173 | 116 |
| 145 64 635 | Piston pump 080L-L-4H | 244 | 228 | 91 | 110 | 173 | 116 |
| 145 64 640 | Piston pump 080L-HP-R-4H | 269 | 251 | 108 | 129 | 198 | 127 |
| 145 64 645 | Piston pump 080L-HP-L-4H | 269 | 251 | 108 | 129 | 198 | 127 |
| 145 64 700 | Piston pump 110L-HP-R-4H | 273 | 251 | 108 | 129 | 198 | 127 |
| 145 64 705 | Piston pump 110L-HP-L-4H | 273 | 251 | 108 | 129 | 198 | 127 |

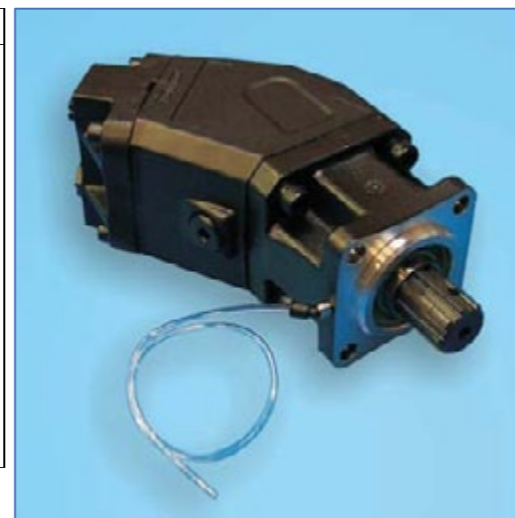

Piston Pumps - Parker Hannifin ISO 4H: L/R Rotational

To complement the Hyva pump range, Hyva uses Parker piston pumps for high pressure applications. They can be fitted with a bypass valve for mounting to constant drives.

| Part no. | Description | Displacement | Weight | Press. side | Torque @ 350 bar | Shaft speed @ 350 bar | Work Press. | Max Int Press. |
|----------|--------------------------|-----------------------|--------|-------------|------------------|-----------------------|-------------|----------------|
| 14535150 | Piston Pump 025-R-4H-PAR | 25.6 cm ³ | 8.5kg | G 3/4" | 142Nm | 2600 RPM | 350 bar | 400 bar |
| 14535155 | Piston Pump 025-L-4H-PAR | | | | | | | |
| 14535160 | Piston Pump 041-R-4H-PAR | 40.9 cm ³ | 8.5kg | G 3/4" | 227Nm | 2400 RPM | 350 bar | 400 bar |
| 14535165 | Piston Pump 041-L-4H-PAR | | | | | | | |
| 14535170 | Piston Pump 050-R-4H-PAR | 51.1 cm ³ | 8.5kg | G 3/4" | 284Nm | 2200 RPM | 350 bar | 400 bar |
| 14535175 | Piston Pump 050-L-4H-PAR | | | | | | | |
| 14535180 | Piston Pump 061-R-4H-PAR | 59.5 cm ³ | 8.5kg | G 3/4" | 331Nm | 2200 RPM | 350 bar | 400 bar |
| 14535185 | Piston Pump 061-L-4H-PAR | | | | | | | |
| 14535190 | Piston Pump 081-R-4H-PAR | 81.6 cm ³ | 12.5kg | G1" | 453Nm | 2000 RPM | 350 bar | 400 bar |
| 14535195 | Piston Pump 081-L-4H-PAR | | | | | | | |
| 14535200 | Piston Pump 101-R-4H-PAR | 102.9 cm ³ | 12.5kg | G1" | 572Nm | 1800 RPM | 350 bar | 400 bar |
| 14535205 | Piston Pump 101-L-4H-PAR | | | | | | | |

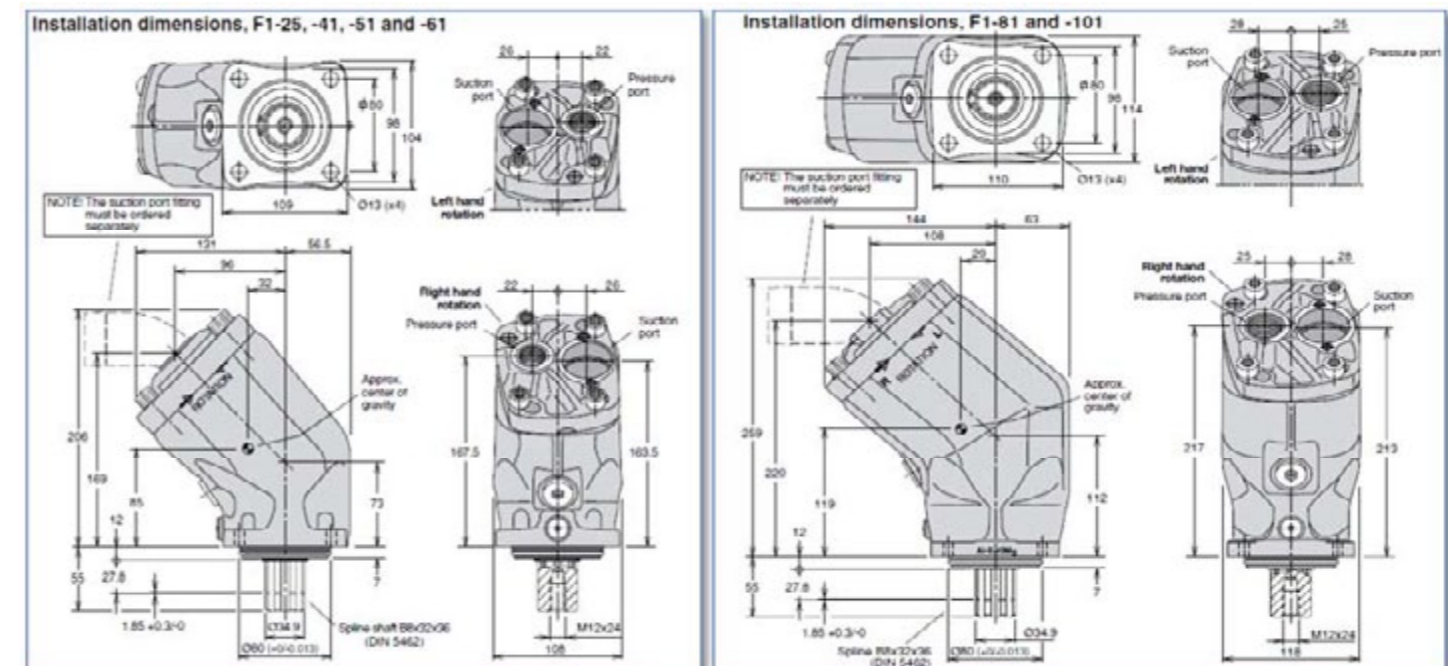

Parker Suction fittings – (Not included with pump)

*Includes fitting, clamps, cap screws & o ring

Straight Adaptor

| Part no. | Description | A mm | B mm | C inch |
|----------|-------------------------|------|------|--------|
| 14535310 | Suction adaptor ST 1 ½" | 0 | 85 | 1 ½" |
| 14535311 | Suction adaptor ST 2" | 17 | 136 | 2" |
| 14535312 | Suction adaptor ST 2 ½" | 25 | 145 | 2 ½" |

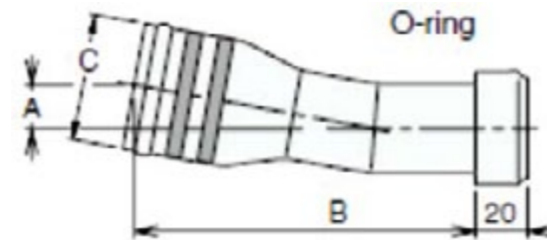

90° Adaptor

| Part no. | Description | A mm | B mm | C inch |
|----------|--------------------------|------|------|--------|
| 14535320 | Suction adaptor 90° 1 ½" | 126 | 83 | 1 ½" |
| 14535321 | Suction adaptor 90° 2" | 135 | 83 | 2" |
| 14535322 | Suction Adaptor 90° 2 ½" | 147 | 103 | 2 ½" |

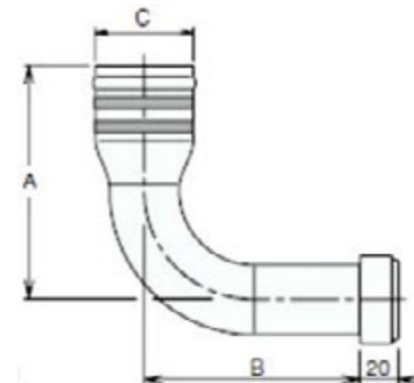

45° Adaptor

| Part no. | Description | A mm | B mm | C inch |
|----------|--------------------------|------|------|--------|
| 14535300 | Suction adaptor 45° 1 ¼" | 60 | 104 | 1 ¼" |
| 14535303 | Suction adaptor 45° 1 ½" | 60 | 104 | 1 ½" |
| 14535305 | Suction Adaptor 45° 2" | 67 | 110 | 2" |
| 14535306 | Suction Adaptor 45° 2 ½" | 75 | 117 | 2 ½" |

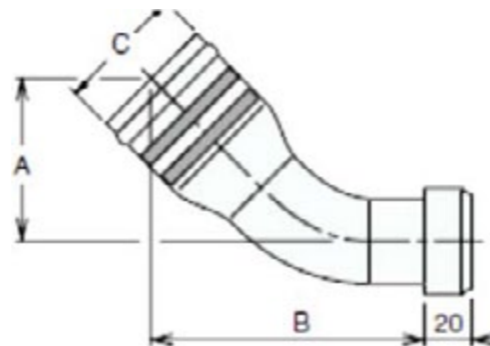

Parker Bypass Valve

The bypass valve is used when the pump is driven from a constant drive i.e.: engine mounted. The valve function is activated by an electric solenoid.

| | |
|-------------------|--|
| MAX press cont: | 350 bar |
| MAX press int: | 400 bar |
| Solenoid voltage: | 24vDc |
| Power req: | 17w |
| Operating mode: | Activated solenoid check valve closed |

| Part no. | Description | volts |
|----------|------------------------------|-------|
| 14535380 | Bypass valve VOAC 12v-25-61 | 12vdc |
| 14535381 | Bypass valve VOAC 24v-25-61 | 24vdc |
| 14535385 | Bypass valve VOAC 12v-81-101 | 12vdc |
| 14535386 | Bypass valve VOAC 24v-81-101 | 24vdc |

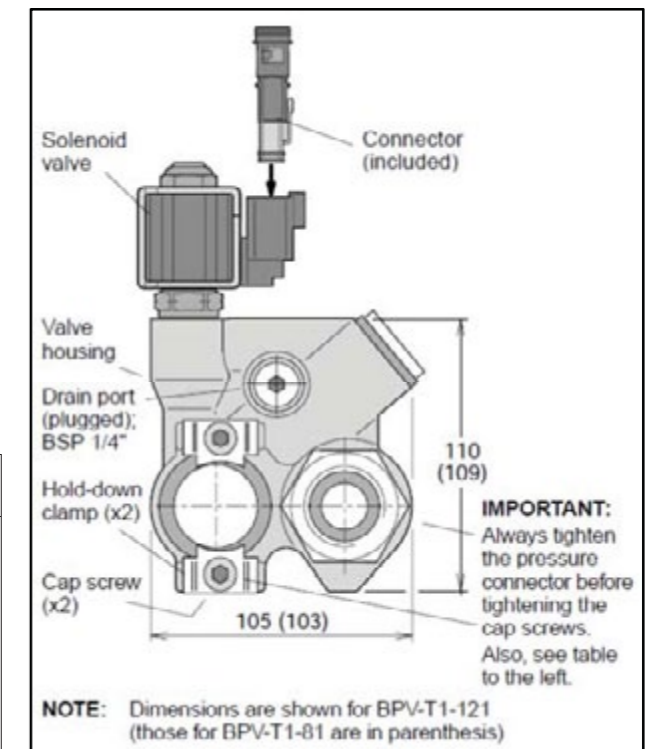

Variable Displacement Piston Pump ISO 4 H: L/R Rotational

| Part no. | Description | displacement | weight | inlet | outlet | LS line | rotation frequency | max. press. | torque (at 300 bar) |
|------------|--------------------------------|---------------------|---------|-------|--------|---------|--------------------|-------------|---------------------|
| 145 25 052 | Piston pump 075L-R-4H variable | 75 cm ³ | 26.8 kg | G1½" | G¾" | G¾" | 2000 | 400 bar | 410 Nm |
| 145 25 053 | Piston pump 075L-L-4H variable | 75 cm ³ | 26.8 kg | G1½" | G¾" | G¾" | 2000 | 400 bar | 410 Nm |
| 145 25 054 | Piston pump 092L-R-4H variable | 92 cm ³ | 26.8 kg | G1½" | G¾" | G¾" | 1900 | 380 bar | 483 Nm |
| 145 25 055 | Piston pump 092L-L-4H variable | 92 cm ³ | 26.8 kg | G1½" | G¾" | G¾" | 1900 | 380 bar | 483 Nm |
| 145 25 056 | Piston pump 120L-R-4H variable | 120 cm ³ | 26.8 kg | G1½" | G1" | G¾" | 2100 | 360 bar | 680 Nm |
| 145 25 057 | Piston pump 120L-L-4H variable | 120 cm ³ | 26.8 kg | G1½" | G1" | G¾" | 2100 | 360 bar | 680 Nm |

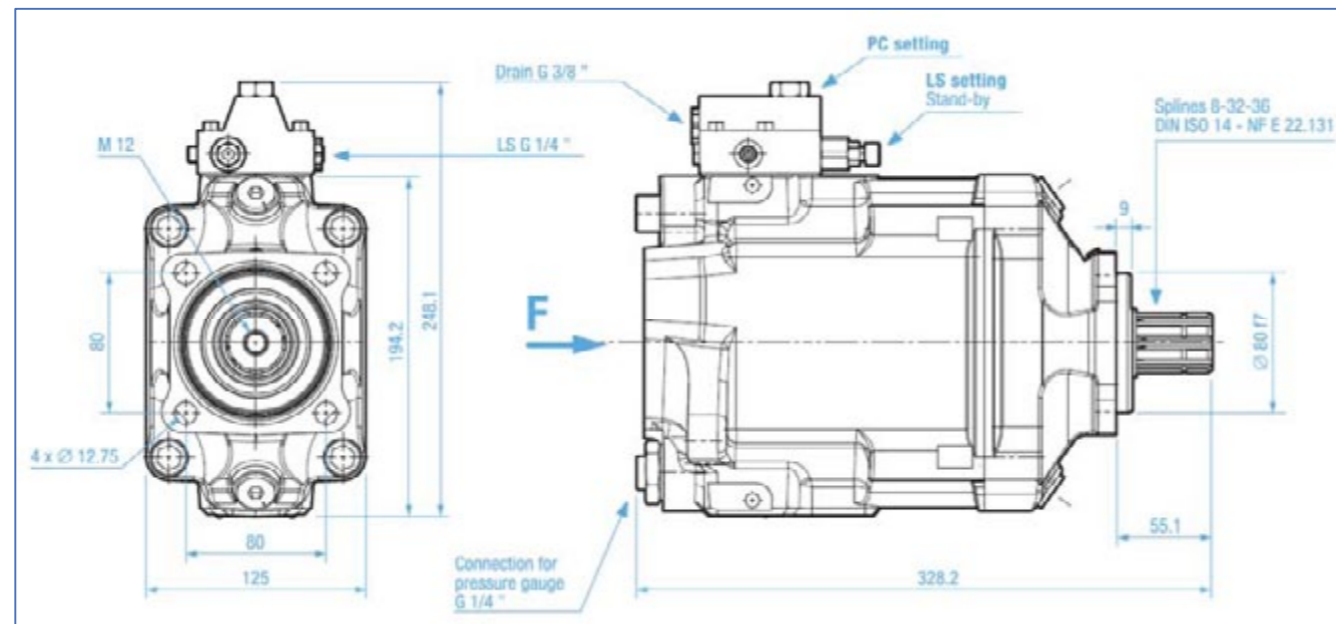

Pump Accessories – PTO to Pump Adaptors

| 3 Hole PTO to 3 Hole pump | |
|---------------------------|---|
| Part no. | Description |
| 02050020H | Coupling kit 3H UNI 6 spline to 6 spline |
| 02050015H | Coupling kit 3H UNI 6 spline to 13 spline |
| 02050065H | Coupling kit 3H UNI 6 spline to 9 spline |
| Coupling length 30mm | |



| 3 Hole PTO to 4 Hole pump | |
|---------------------------|----------------------------------|
| Part no. | Description |
| 021415006 | Adaptor 3H UNI PTO – 4H ISO Pump |
| Coupling length 70mm | |



| 4 Hole PTO to 3 Hole pump | |
|---------------------------|--|
| Part no. | Description |
| 021415022 | 4H ISO PTO to 3H UNI Pump |
| 021415003 | 4H ISO PTO to 3H UNI Pump (no seal) hi torque |
| 02050407H | 4H ISO PTO to 3H UNI Pump (Double bearing Hi torque) |



021415022



021415003



02050407H

Pump Accessories – PTO to Pump Adaptors

| Part no. | Description |
|-----------|--|
| 021415013 | Adaptor 4 hole PTO – SAE B pump 13 teeth |

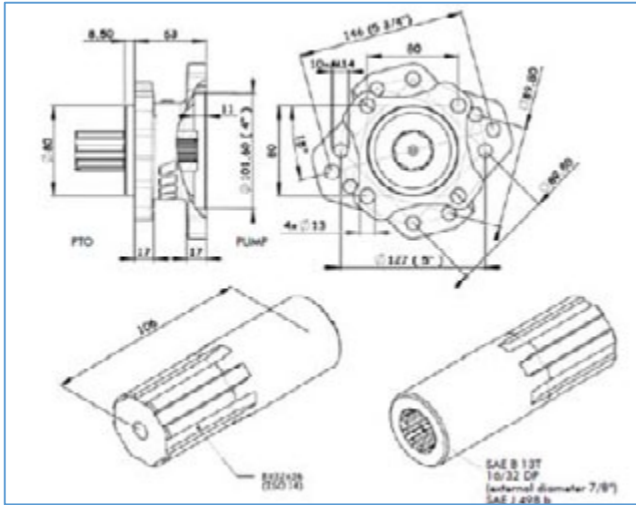

| Part no. | Description |
|-----------|-----------------------------------|
| 021415005 | Adaptor POWAUTO PTO – 3 Hole PUMP |

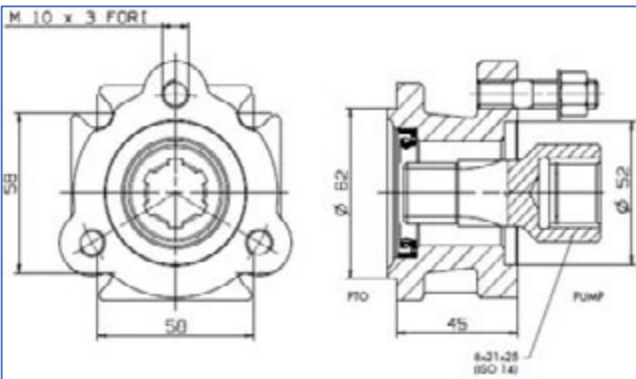

| Part no. | Description |
|-----------|-----------------------------------|
| 02050434H | Adaptor Chelsea PTO – 3 Hole PUMP |



Pump accessories – Pump Adaptors

| Part no. | Description |
|-----------|---------------------------------|
| 05050372H | 3H UNI PUMP orientation adaptor |



| Part no. | Description |
|-----------|-----------------------------|
| 02050463H | Flange kit 38 – Spicer 1410 |



Pump Accessories – Gaskets

| Part no. | Description |
|------------|---------------|
| 2PMPGASKET | 3 hole gasket |



| Part no. | Description |
|----------|---------------|
| 14625850 | 4 hole gasket |



Pump Accessories – Seal Kits

| Part no. | Description |
|----------|---------------------------------|
| 02460055 | FP 200 series seal kit |
| 02470840 | APL series seal kit |
| 02460060 | FP 300 series seal kit |
| 02460070 | FP 400 series seal kit |
| 02460000 | Brite series seal kit 34 -82L |
| 02460005 | Brite series seal kit 92 - 113L |



Hydro Electric Power Packs – single Acting

| Part No. | Description SINGLE ACTING | Voltage (Vdc) | Nominal power (Watt) | Pump size (Cc/rev.) | Tank steel volume (L) | Max pressure (Bar) | Current at max press. (Amps) | Flow at max bar (LPM) |
|-----------|-------------------------------------|------------------|-------------------------|------------------------|--------------------------|-----------------------|---------------------------------|--------------------------|
| 14550510H | 12vdc single acting | 12 | 1600 | 2.1 | 10 | 150 | 290 | 5.9 |
| 14550530H | 24vdc single acting | 24 | 2200 | 2.1 | 10 | 150 | 290 | 5.9 |
| 14554080 | single acting pendant control | | | | | | | |

15 litre tanks available on request

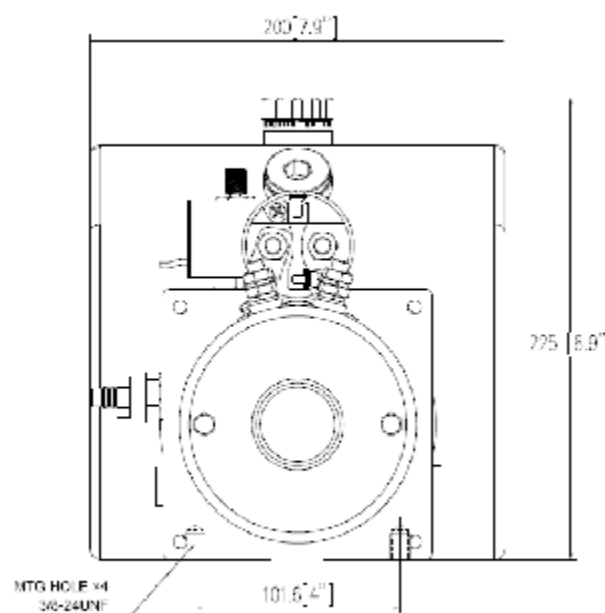
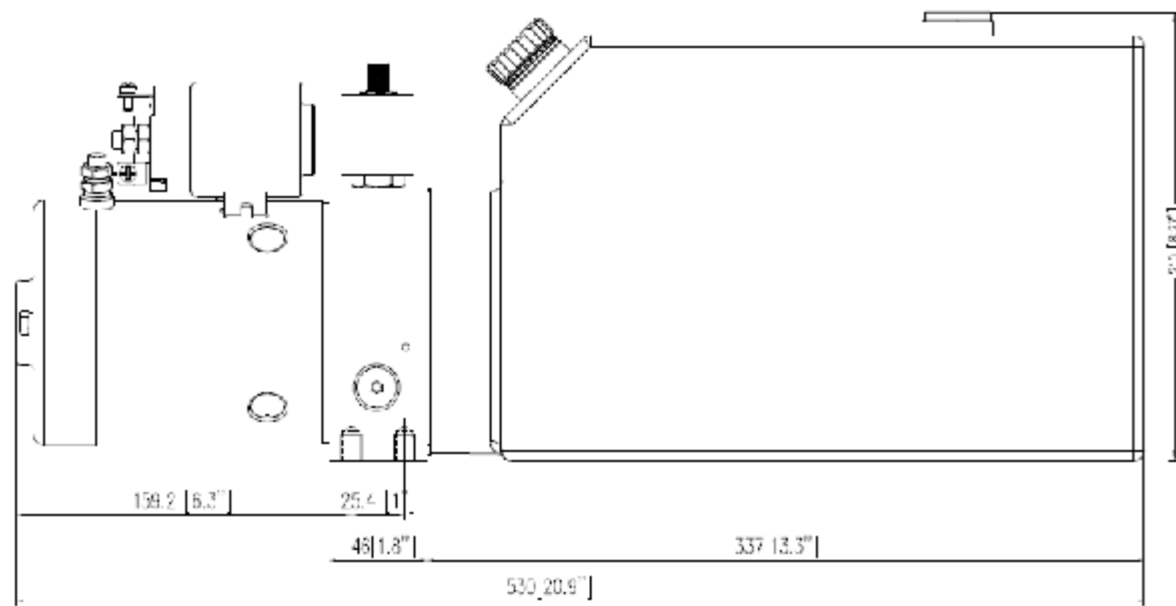

Hydro Electric Power Packs – Double Acting

| Part No. | Description DOUBLE ACTING | Voltage (Vdc) | Nominal power (Watt) | Pump size (Cc/rev.) | Tank steel volume (L) | Max pressure (Bar) | Current at max press. (Amps) | Flow at max bar (LPM) |
|-----------|-------------------------------------|------------------|-------------------------|------------------------|--------------------------|-----------------------|---------------------------------|--------------------------|
| 14550063H | 12vdc double acting | 12 | 1600 | 2.1 | 10 | 210 | 165 | 10 |
| 14550540H | 24vdc double acting | 24 | 2200 | 2.1 | 10 | 210 | 165 | 10 |
| 14550490 | double acting pendant control | | | | | | | |

15 litre tanks available on request

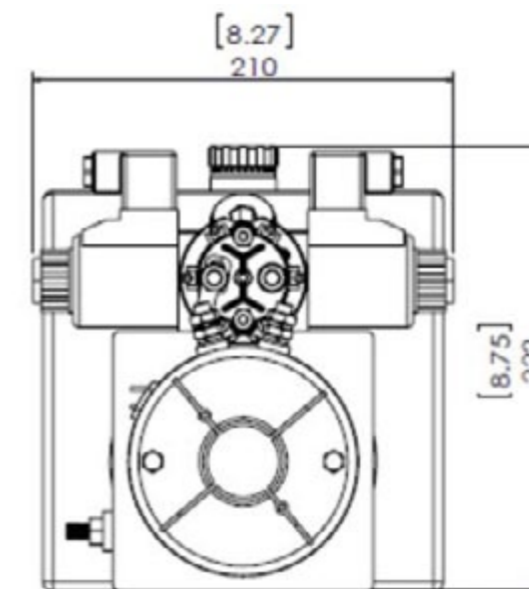
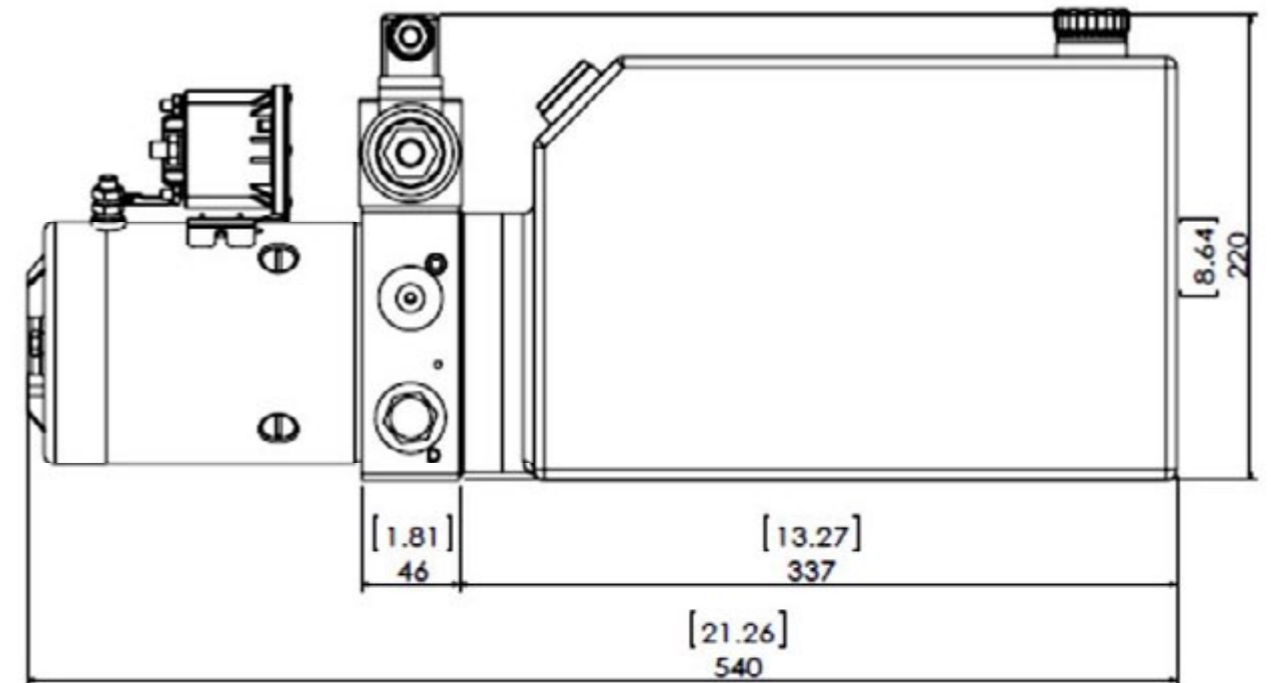

Hyva Valves

Hyva Tipping Valves

Hyva offers a complete range of tipping valves to be used for different cylinder volumes. The HT 1220 & PT 2200 valves can be used for flows up to 220 litre per minute. The pressure settings are from 150 to 350 bar. The HT/PT valves have fully interchangeable pressure cartridges, so you can adjust the pressure settings yourself. Dual pressure valves are available as well. For smaller flows you can use the electronic or Low flow range.

The Hyva HT 1220 & PT 2220 tipping valves are constructed with a pilot operated pressure relief valve with fixed pressure setting (by means of cartridges), which protects both the cylinder and the pump for overpressure.

This tipping valve is also designed to allow proportional lowering, which is of main importance when lowering (half) loaded bodies. This tipping valve can be directly fitted to the Hyva oil tank, which reduces the number of hoses and fittings and consequently restrictions and the possibility of leakages.

The Hyva HT/PT valves can be mounted directly to the hyva oil tank. This saves cost by minimising hosing, and increases efficiency and reliability by decreasing leak points.



* The set-up on the right, shows a rear mounted tank (TR165MFC) with a HT valve (147 67 117). Only 2 hoses are required, a suction from the tank to the pump, and a pressure hose from the pump to the valve.

Other valves

Apart from special tipping valves, Hyva also supplies a variety of flow-, pressure and motion control valves such as knock-off valves, sequence valves, series and parallel flow control valves, pressure relief valves, hose failure valves, non-return valves, over-centre valves etc.

Hyva also supplies a full range of mono-block and bankable spool valves up to 12 sections with flows from 45 to 160 l/m, various controls and options such as port relief valves and flow control sections.

HT 1220 Tipping Valve Single Pressure

Standard tipping valve for medium to large trucks, can be mounted directly to a hyva oil tank or chassis mounted (with kit 14735208). A diverter valve (14708603H) can be mounted directly to the output port for dual tipping applications. This valve also has an interchangeable pressure cartridge.

| Part no. | Description | Max Flow | Max Pressure | Ports | Weight |
|------------|---|----------|--------------|-------|--------|
| 147 67 117 | Tipping valve – HT1220 – 170 | 220L/min | 170 bar | G1" | 6.4kg |
| 147 35 168 | Tank mounting kit (Included with valve) | | | | |

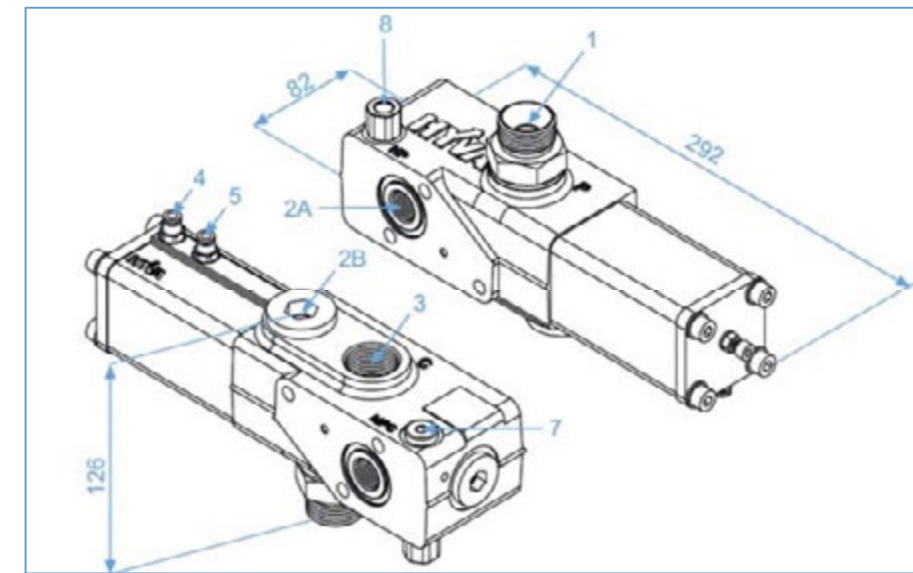

- 1 : pump connection (P)
- 2A : return tank connection (T)
- 2B : alternative return tank connection (T)
- 3 : cylinder connection (C)
- 4 : connection to pneumatic control - tip (6mm push-in)
- 5 : connection to pneumatic control - lower (6mm push-in)
- 7 : pressure gauge point
- 8 : cartridge

Pressure Cartridge for HT Valve

| Part no. | Description |
|------------|---------------------------------|
| 147 72 110 | Pressure cartridge HT - 110 bar |
| 147 72 135 | Pressure cartridge HT - 135 bar |
| 147 72 150 | Pressure cartridge HT - 150 bar |
| 147 72 170 | Pressure cartridge HT - 170 bar |
| 147 72 190 | Pressure cartridge HT - 190 bar |
| 147 72 220 | Pressure cartridge HT - 220 bar |
| 147 72 250 | Pressure cartridge HT - 250 bar |
| 147 72 280 | Pressure cartridge HT - 280 bar |
| 147 72 315 | Pressure cartridge HT - 315 bar |
| 147 72 350 | Pressure cartridge HT - 350 bar |



PT 2220 Tipping Valve Double Pressure

This valve has the same features as the HT valve, with the added capability of running dual pressures, which is changed via the pressure selector on the valve.

| Part no. | Description | Max Flow | Max Pressure | Ports | Weight |
|------------|---|----------|-------------------|-------|--------|
| 147 67 355 | Tipping valve – PT2220 – 150-250 | 220L/min | 150 bar – 250 bar | G1" | 6.4kg |
| 147 35 168 | Tank mounting kit (Included with valve) | | | | |
| 148 44 010 | PT Valve seal kit | | | | |

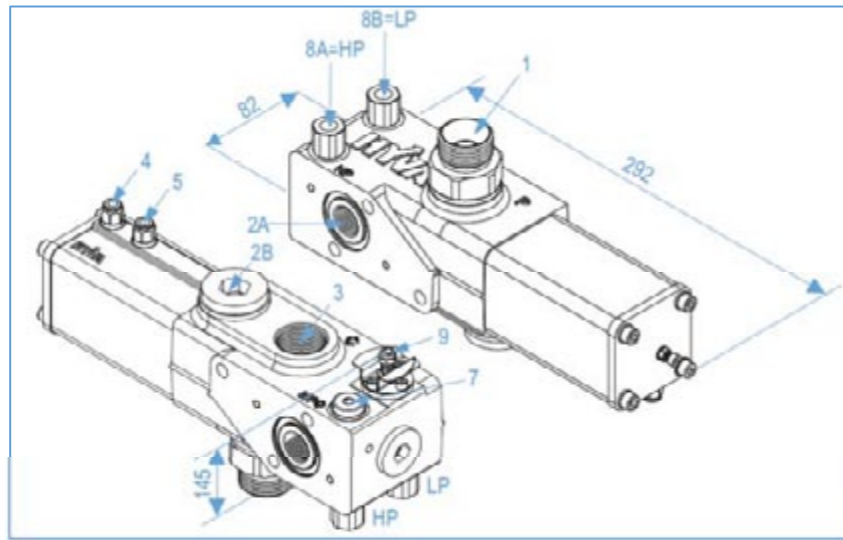

- 1 : pump connection (P)
- 2A : return tank connection (T)
- 2B : alternative return tank connection (T)
- 3 : cylinder connection (C)
- 4 : connection to pneumatic control - tip (6mm push-in)
- 5 : connection to pneumatic control - lower (6mm push-in)
- 7 : pressure gauge point
- 8 : cartridge

Pressure Cartridge for PT Valve

| Part no. | Description |
|------------|---|
| 147 71 135 | Pressure cartridge PT 1220/2220 - 135 bar |
| 147 71 150 | Pressure cartridge PT 1220/2220 - 150 bar |
| 147 71 170 | Pressure cartridge PT 1220/2220 - 170 bar |
| 147 71 190 | Pressure cartridge PT 1220/2220 - 190 bar |
| 147 71 220 | Pressure cartridge PT 1220/2220 - 220 bar |
| 147 71 250 | Pressure cartridge PT 1220/2220 - 250 bar |
| 147 71 280 | Pressure cartridge PT 1220/2220 - 280 bar |
| 147 71 300 | Pressure cartridge PT 1220/2220 - 300 bar |
| 147 71 320 | Pressure cartridge PT 1220/2220 - 320 bar |
| 147 71 350 | Pressure cartridge PT 1220/2220 - 350 bar |



Mounting kits for HT/PT Valves

Chassis mount kit

| Pos. | Part no. | Description | Qty. |
|------|------------|--|------|
| | 147 35 208 | chassis mounting kit PT-valve consisting of: | |
| 1 | 147 35 210 | mounting plate | 1 |
| 2 | 012 06 837 | bonded seal | 1 |
| 3 | 147 99 180 | Allen plug with collar ½" | 1 |

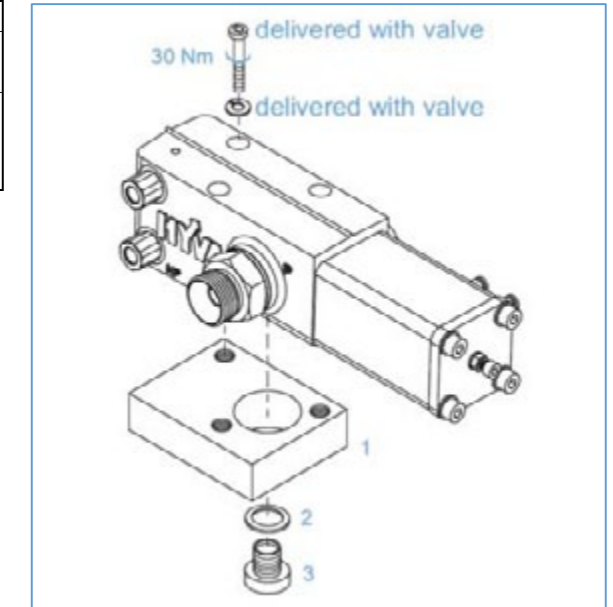
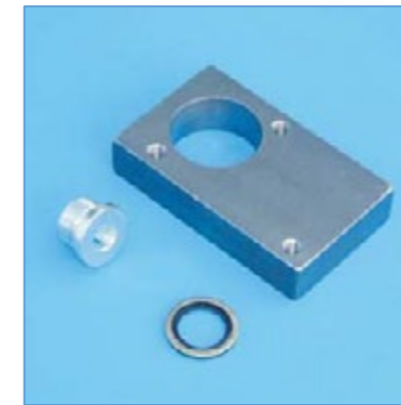

Tank mount kit (included with HT/PT valves)

| Pos. | Part no. | Description | Qty. |
|------|------------|--|------|
| | 147 35 168 | Tank mounting kit HT/PT-valve consisting of: | |
| 1 | 150 13 645 | Bolt | 3 |
| 2 | 150 24 080 | Locking ring | 3 |
| 3 | 012 25 607 | O-ring | 1 |
| 4 | 012 25 607 | PVC plug | 3 |

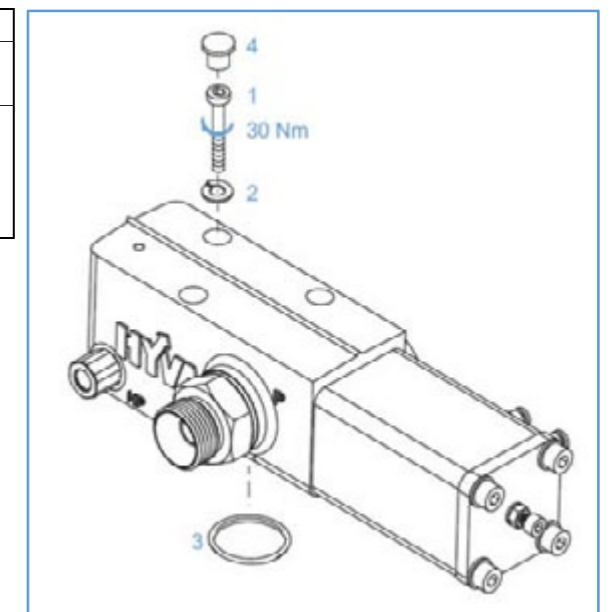

Small Tipping Valve

| Part no. | Description | Max Flow | Set Press. | Adjustable press. range | Ports | Air Ports | Weight |
|-------------|-----------------------------|----------|------------|-------------------------|--------|-----------|--------|
| 147 083 20C | Tipping valve – small - 100 | 100 LPM | 120 bar | 100 – 350 bar | G 3/4" | 1/8" | 4.5kg |

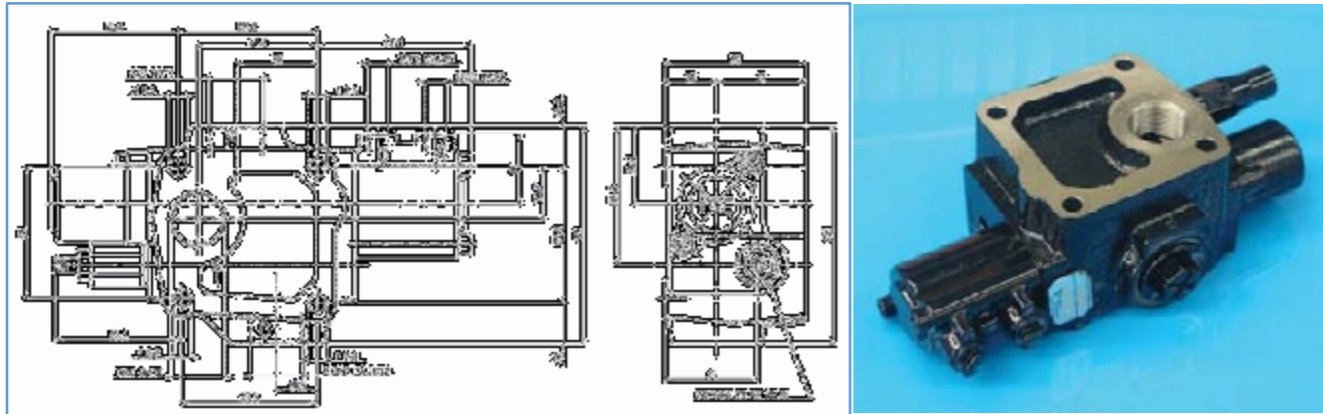

Dual Spool Tipping Valve

| Part no. | Description | Max Flow | Max Pressure | Ports | Air Ports | Weight |
|------------|----------------------------------|----------|--------------|-------|-----------|--------|
| 147 05 707 | Tipping valve – dual spool – 210 | 180L/min | 210 bar | G1" | 1/8" | 12kg |

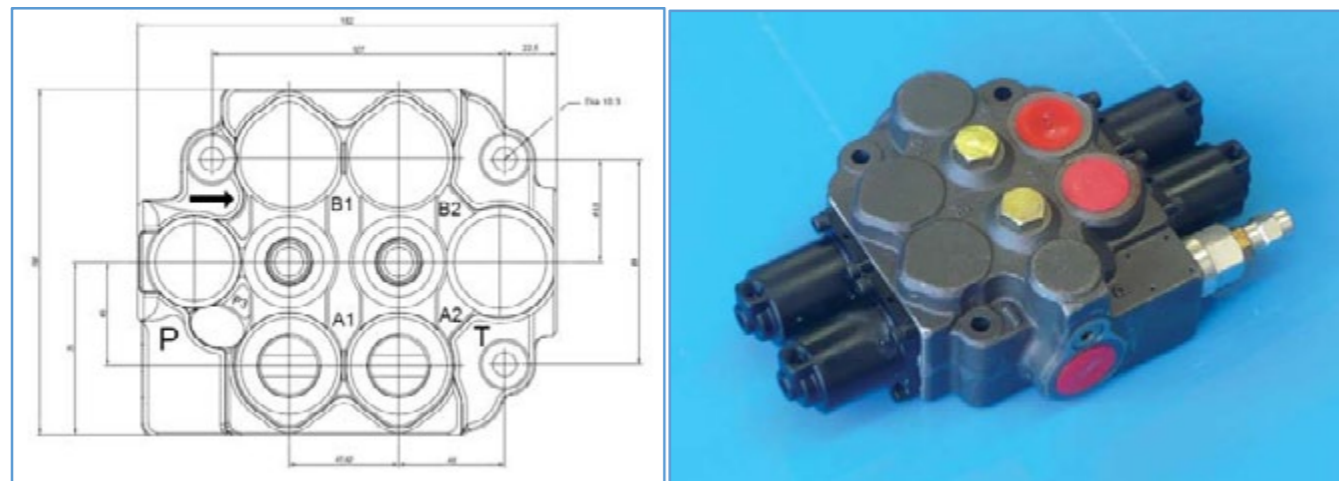

Electric Tipping Valves

| Part no. | Description | Max Flow | Set Press. | Adjustable press. range | Ports | Weight |
|-----------|----------------------------------|----------|------------|-------------------------|--------|--------|
| 14708551H | Tipping valve – electric12vdc-40 | 40 LPM | 120 bar | 100 – 250 bar | G 1/2" | 3.6kg |
| 021418140 | Tipping valve – electric24vdc-40 | 40 LPM | 140 bar | 100 – 240 bar | G 1/2" | 3.4kg |

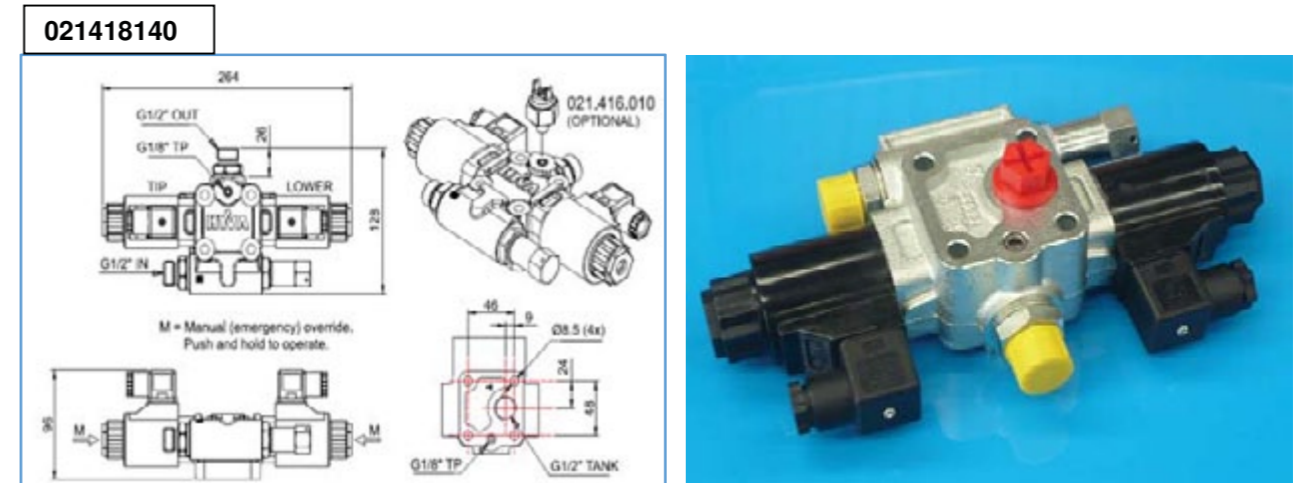
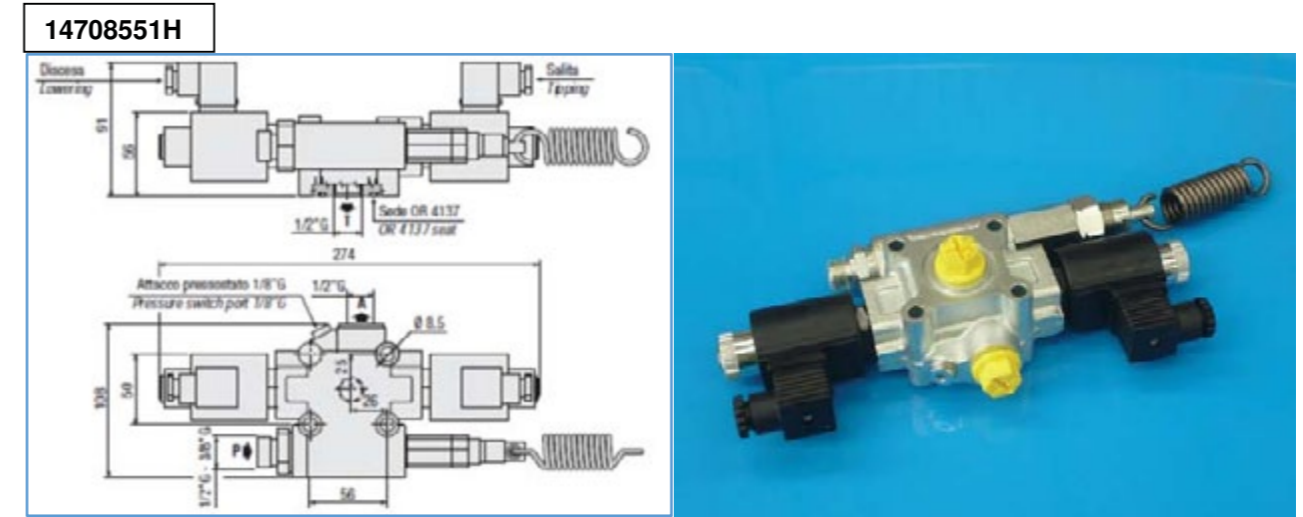

Manual operated diverter valves

| Part no. | Description | Max. press. | Ports | | | Flow (L/min) | L1 (mm) | L2 (mm) | W (mm) | H (mm) | Weight (kg) |
|-------------|------------------------------|-------------|-------|-----|-----|--------------|---------|---------|--------|--------|-------------|
| | | | P | A | B | | | | | | |
| 021 418 010 | Diverter valve 3-way man.-½" | 400 bar | G½" | G½" | G½" | 110 | 86 | 154.5 | 91.6 | 73.3 | 1.80 |
| 021 418 011 | Diverter valve 3-way man.-¾" | 400 bar | G¾" | G¾" | G¾" | 110 | 88 | 154.5 | 99 | 78.8 | 2.15 |
| 147 40 037 | Diverter valve 3-way man.-1" | 400 bar | G1" | G1" | G1" | 150 | 98 | 204 | 108.5 | 90.5 | 3.70 |

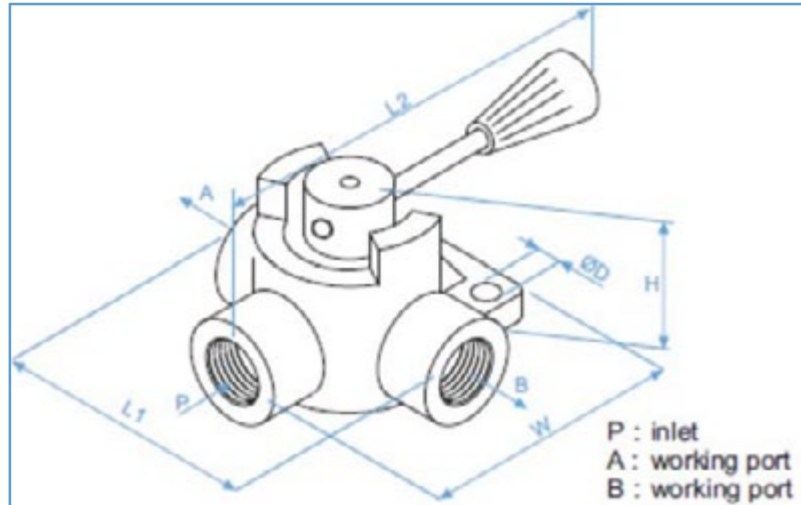

Air operated diverter valves

| Part no. | Description | Max Flow | Max Press. | Ports | Air Port | Weight |
|-------------|-----------------------------|----------|------------|-------|------------|--------|
| 147 086 03H | Diverter valve 3-way-AIR-1" | 200 LPM | 350 bar | G 1" | M12 x 1.25 | 2.6kg |

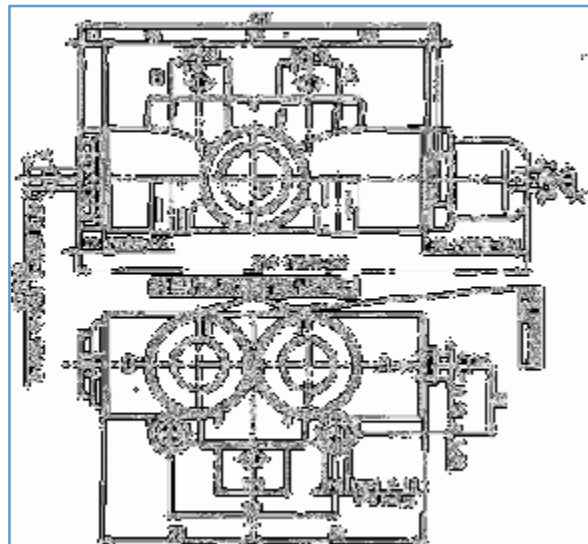

Pressure relief valve - adjustable

| Part no. | Description | Press. (Bar) | Ports | | Flow (L/min) | Weight (kg) | A (mm) | B (mm) | C (mm) | D (mm) | E (mm) | F (mm) | G (mm) | H (mm) |
|------------|--|--------------|-------|----|--------------|-------------|--------|--------|--------|--------|--------|--------|--------|--------|
| | | | P | T | | | | | | | | | | |
| 013 19 875 | Valve pres. relief 100L-210 bar KNOB (alu) | 50-210 | ¾" | ¾" | 100 | 1.1 | 70 | 100 | 50 | 50 | 22 | 54 | 57 | 95 |

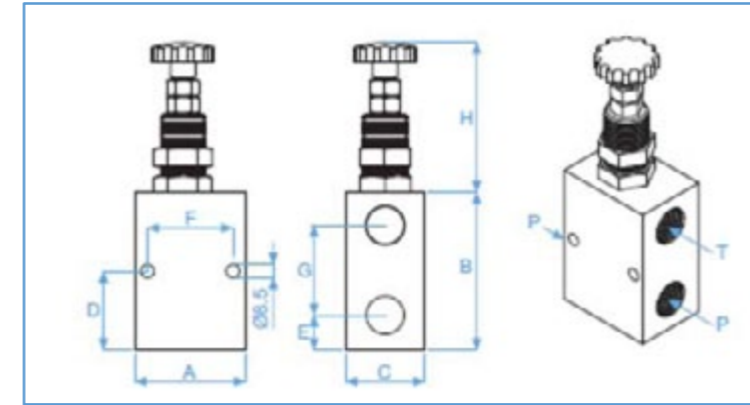

Pressure relief valve

| Part no. | Description | Press. (bar) | Ports | | Flow (L/min) | Weight (kg) | A (mm) | B (mm) | C (mm) | D (mm) | E (mm) | F (mm) | G (mm) | H (mm) |
|------------|--|--------------|-------|----|--------------|-------------|--------|--------|--------|--------|--------|--------|--------|--------|
| | | | P | T | | | | | | | | | | |
| 013 19 880 | Valve pres. relief 100L-210 bar BOLT (alu) | 50-210 | ¾" | ¾" | 100 | 1.1 | 70 | 100 | 50 | 50 | 22 | 54 | 57 | 76.5 |
| 013 19 885 | Valve pres. relief 100L-350 bar BOLT (steel) | 180-350 | ¾" | ¾" | 100 | 2.4 | 70 | 100 | 50 | 50 | 22 | 54 | 57 | 76.5 |
| 013 19 890 | Valve pres. relief 100L-350 bar BOLT (steel) | 180-350 | 1" | 1" | 100 | 2.4 | 85 | 120 | 60 | 63 | 30 | 65 | 65 | 76.5 |

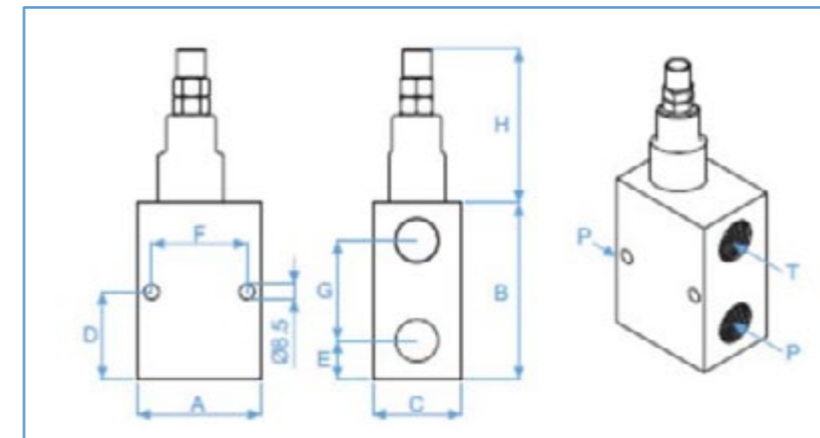

Hose Burst Valve

A hose burst valve protects a driver and truck from a falling body in case of a hose burst, as well as protecting the environment from a huge oil spill. The hose burst valve will close as soon as the flow from the cylinder exceeds 215LPM. The valve mounts directly to the port on a Hyva cylinder.

| Part no. | Description | Max. press. (bar) | Ports | Flow (L/min) | Weight (kg) |
|------------|------------------------|-------------------|-------|--------------|-------------|
| 147 42 101 | Hose burst valve 1"SAE | 190 bar | 1" | 215 | 4.0 |

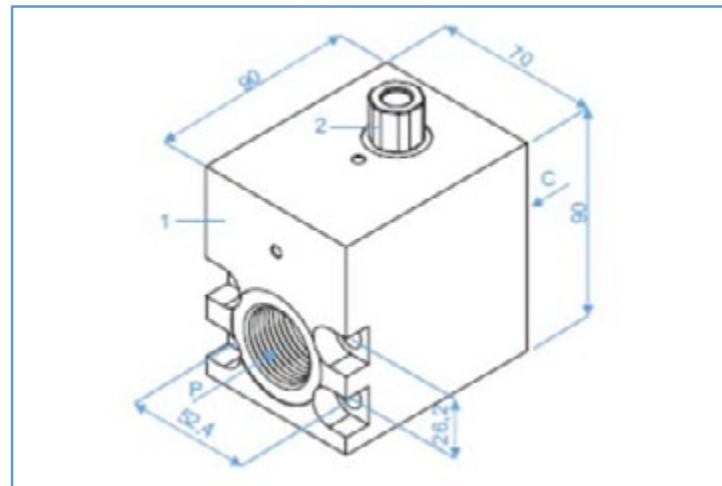

- 1 : valve housing
- 2 : pressure cartridge (14771190)
- C : C-port; connect direct to cylinder
- P : P-port; connect to hose

Flow Restrictor Valves

| Part no. | Description | Max.press (bar) | Ports | Dimensions | | | Flow (L/min) | Weight (kg) |
|------------|-----------------------|-----------------|-------|------------|----|----|--------------|-------------|
| | | | | L | H | KW | | |
| 147 00 485 | Flow restrictor valve | 400 bar | G3/8" | 72 | 42 | 24 | 40 | 0.6 |
| 147 00 484 | Flow restrictor valve | 300 bar | G3/4" | 100 | 55 | 36 | 100 | 0.5 |

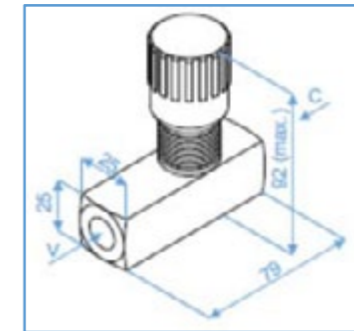
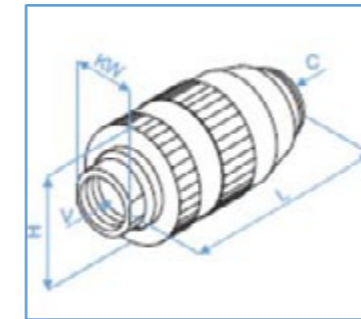

- C : cylinder connection
- V : valve connection

| Part no. | Description | Max. press. (bar) | Ports | Flow (L/min) | Weight (kg) |
|------------|-----------------------|-------------------|-------|--------------|-------------|
| 092 35 651 | Flow restrictor valve | 400 bar | 3/8" | 40 | 0.5 |

Multi-Section Valve

| Part no. | Description | Press. (bar) | Ports | | | Flow (L/min) |
|------------|--|--------------|-------|------|------|--------------|
| | | | P | A/B | T | |
| 147 02 610 | Section valve-080-2-DA/SA-180-PN | 180 | 1/2" | 1/2" | 3/4" | 80 |
| 147 02 620 | Section valve-080-2-SA/DA-280-PN | 280 | 1/2" | 1/2" | 3/4" | 80 |
| 147 02 710 | Section valve-080-3-DA/SA/SA-180-PN | 180 | 1/2" | 1/2" | 3/4" | 80 |
| 147 02 810 | Section valve-080-4-DA/DA/SA/SA-180-PN | 180 | 1/2" | 1/2" | 3/4" | 80 |
| 147 02 815 | Section valve-080-4-DA/DA/SA/SA-280-PN | 280 | 1/2" | 1/2" | 3/4" | 80 |
| 147 02 820 | Section valve-080-4-SA/SA/DA/DA-280-PN | 280 | 1/2" | 1/2" | 3/4" | 80 |
| 147 03 120 | Section valve-140-2-DA/SA-280-PN | 280 | 3/4" | 3/4" | 1" | 140 |
| 147 03 125 | Section valve-140-2-DA/SA-170-PN | 170 | 3/4" | 3/4" | 1" | 140 |
| 147 03 210 | Section valve-140-3-SA/DA/DA-170-L | 170 | 3/4" | 3/4" | 1" | 140 |
| 147 03 220 | Section valve-140-3-SA/SA/DA-280-PN | 280 | 3/4" | 3/4" | 1" | 140 |
| 147 03 310 | Section valve-140-4-DA/DA/SA/SA-280-PN | 280 | 3/4" | 3/4" | 1" | 140 |
| 147 05 500 | Section valve-160-3-DA/DA/SA-170-PN | 170 | 1" | 1" | 1" | 160 |
| 147 05 550 | Section valve-160-3-DA/SA/DA-135-L | 135 | 1" | 1" | 1" | 160 |



Non – Return Valve

This valve ensures that the oil flow can only travel through the hydraulic system in one direction (from P to A).The 60° tapered P-port can be connected to a 1" swivel with internal 60° cone without a bonded seal. For all other types of connection a 1"bonded seal (013 13 848) is needed to prevent leakage of oil. The A-port of the valve must always have a 1" bonded seal. Mounting torque of the valve is 100 Nm.

| Part no. | Description | Max. press (bar) | Flow (L/min) | Weight (kg) | L1 (mm) | L2 (mm) | L3 (mm) | SW1 (mm) | ØD1 (") | ØD2 (") |
|-------------|---------------------------|------------------|--------------|-------------|---------|---------|---------|----------|---------|---------|
| 147 39 975A | Non return valve 1" BSPOT | 350 | 220 | 0.3 | 48.5 | 18.5 | 15 | 41 | 1 | 1 |

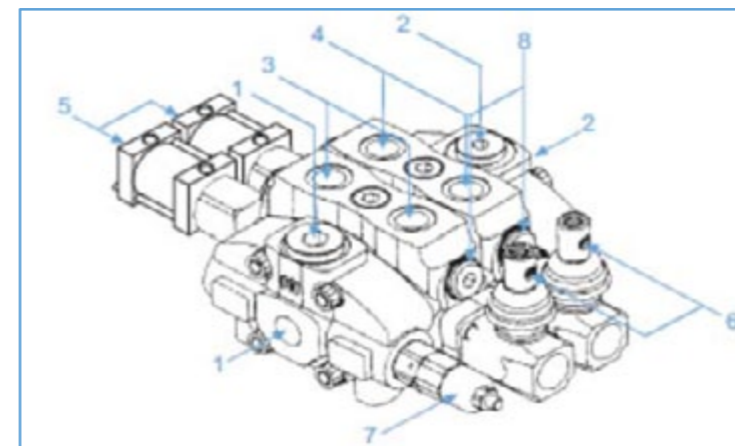
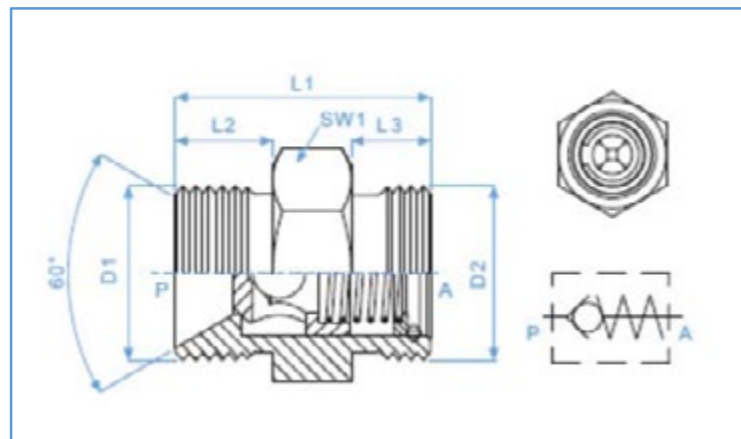

- 1 : pump connection (P)
 - 2 : tank connection* (T)
 - 3 : section 1 connection (A/B)
 - 4 : section 2 connection (A/B)
 - 5 : air actuator
 - 6 : socket for handle
 - 7 : pressure relief valve
 - 8 : port relief valve
- DA = double acting section
 SA = single acting section
 PN = pneumatic operated
 L = lever operated

Hydraulic Knock – Off Valves

| Part no. | Description | Type normally | Press (bar) | Ports | Flow (L/min) | Weight (kg) | L (mm) |
|------------|-------------------------------|---------------|-------------|-------|--------------|-------------|--------|
| 147 20 171 | Knock-off valve 2/2 60L 3/8" | opened | 350 | 3/8" | 60 | 1.628 | - |
| 147 20 211 | Knock-off valve 2/2 120L 1/4" | opened | 350 | 1/4" | 120 | 2.112 | 173 |
| 147 00 509 | Knock-off valve 2/2 60L 3/8" | closed | 350 | 3/8" | 60 | 1.648 | - |
| 147 00 521 | Knock-off valve 2/2 120L 1/4" | closed | 350 | 1/4" | 120 | 2.204 | 179 |

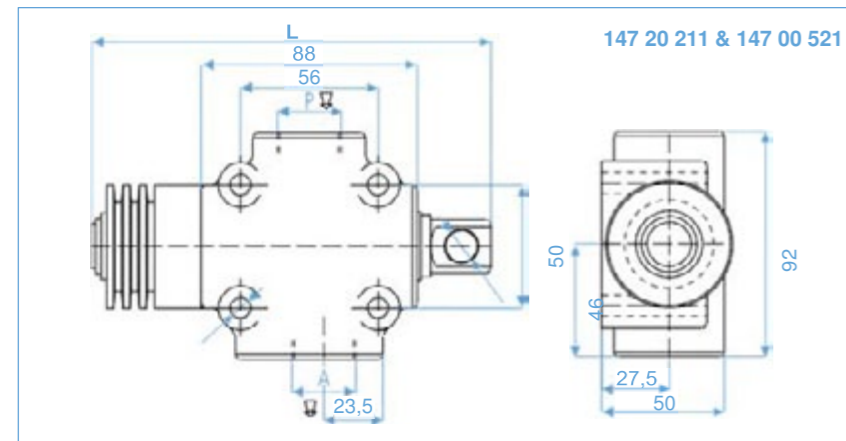
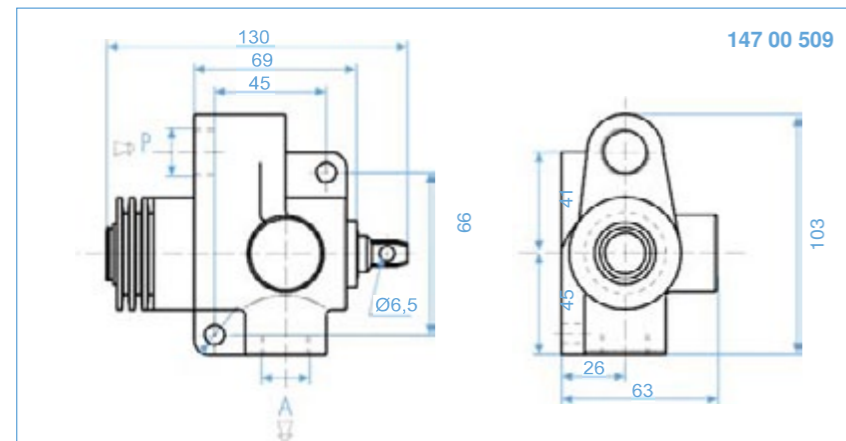
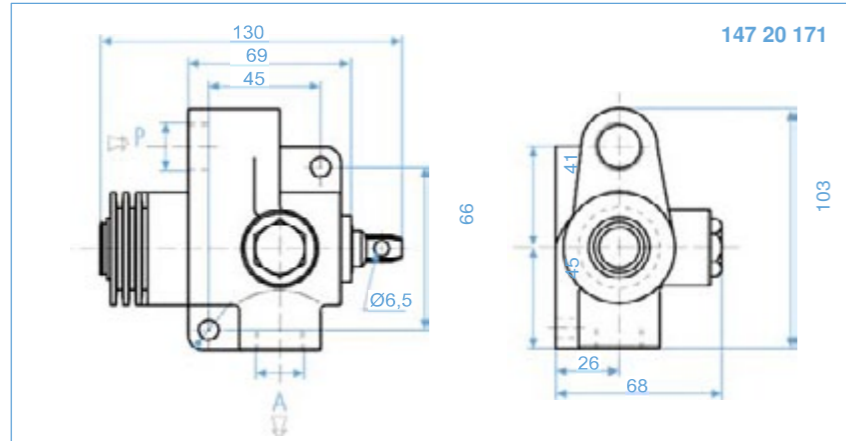
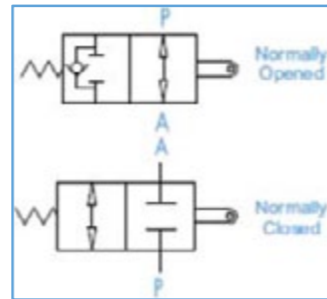

Valve Accessories

Cable control for valve with fixed position

| Part no. | Description | Stroke (mm) | Transmitted force | |
|-------------|------------------------------------|-------------|-------------------|-------|
| | | | pull | push |
| 021 419 370 | Cable control fixed position 1.0 m | 40-45 | 600 N | 350 N |
| 021 419 371 | Cable control fixed position 1.2 m | 40-45 | 600 N | 350 N |
| 021 419 372 | Cable control fixed position 1.5 m | 40-45 | 600 N | 350 N |
| 021 419 373 | Cable control fixed position 2.0 m | 40-45 | 600 N | 350 N |
| 021 419 374 | Cable control fixed position 2.5 m | 40-45 | 600 N | 350 N |
| 021 419 375 | Cable control fixed position 3.0 m | 40-45 | 600 N | 350 N |
| 021 419 376 | Cable control fixed position 3.5 m | 40-45 | 600 N | 350 N |
| 021 419 377 | Cable control fixed position 4.0 m | 40-45 | 600 N | 350 N |
| 021 419 378 | Cable control fixed position 4.5 m | 40-45 | 600 N | 350 N |

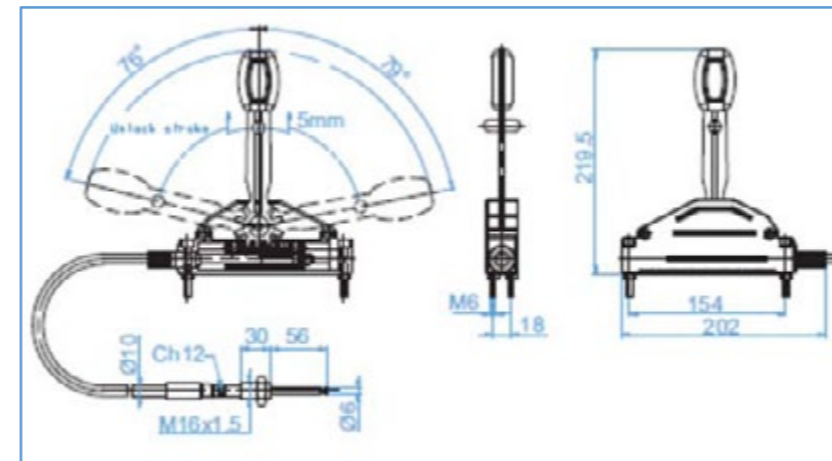

Hydraulic Pressure Indicator Switch

| Part No. | Description |
|---------------|--|
| 148 80 790 DS | Pressure switch 300 bar 1/8" BSP |
| 148 80 791 | Protective cap with dual cable entries |



Hyva Tip Controls

Hyva offers a complete range of tip controls to engage the PTO and control valves in your hydraulic system. The standard Hyva controls meet every local legislation with safety features such as the automatic PTO disengagement. This Feature makes driving with an engaged PTO impossible.

The Tipping controls are standard delivered with three positions; tip, lower and automatic neutral locking position.

Standard Hyva tip controls

The following controls and switches are available:

- Switches for PTO
- Tip control for tipping valve
- Tip control for tipping valve including PTO switch

They are available with or without spring return on tip control. The control for PTO/valve has an automatic disengage on the PTO switch as an option.

The standard controls are equipped with a warning light to show that the PTO is engaged. Perfectly proportional lowering is possible in combination with the Hyva HT valve. Proportional lowering makes partial unloading ever so easy. Detailed spec sheets are available on request.

Narrow Tip controls with additions for multi sections

The Multi section tip controls can be used in cases where more functions should be controlled, for instance tail doors, multi-kaps or hook loaders. This tipping control is ideal for small cabin spaces.

Code system tip control

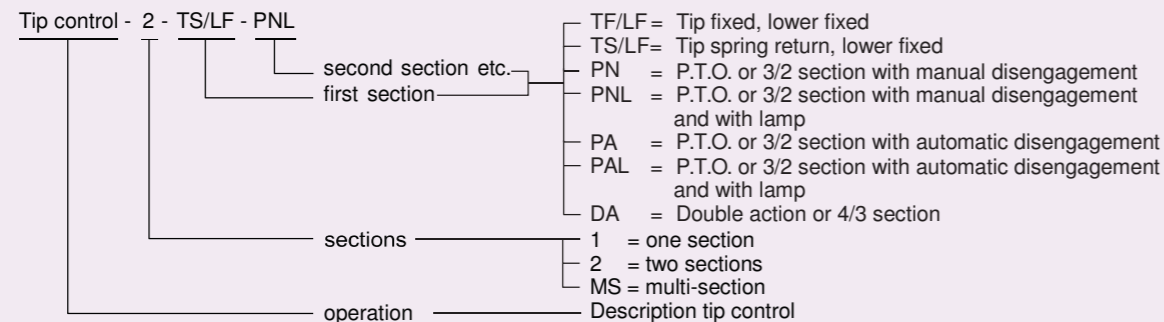

Proportional tip control 1-section (tipping valve control)

| Part no. | Description | Kit no.** | Max Pressure | Min Pressure |
|--------------|-----------------------------------|---------------|--------------|--------------|
| 147 50 665 H | Tip fixed/lower fixed | 147 50 665 HK | 12 bar | 5 bar |
| 147 50 667 H | Tip spring/lower fixed | 147 50 667 HK | 12 bar | 5 bar |
| 147 50 600 | Seal kit for proportional control | | | |

*All ports 6mm push **Kit includes 6mm airline x 20m

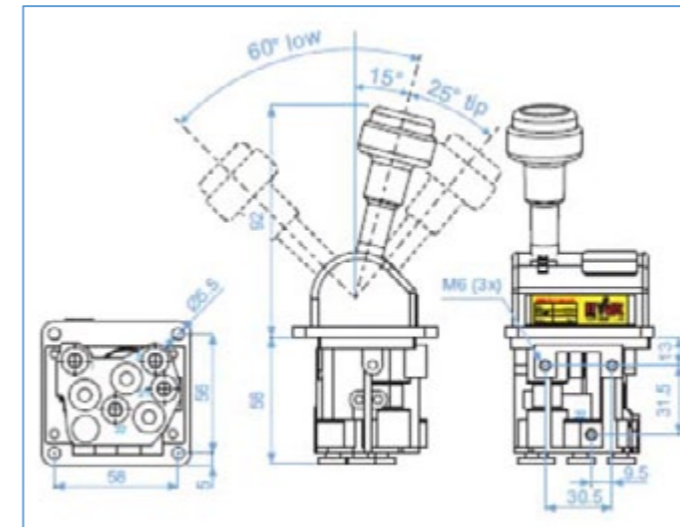

Connections
 1 : air inlet
 3 : air exhaust
 21 : lowering connection (to tipping valve)
 22 : tipping connection (to tipping valve)



Proportional tip control 2-sections (P.T.O. & tipping valve control)

| Part no. | Description | Kit no.** | Max Pressure | Min Pressure |
|--------------|--|---------------|--------------|--------------|
| 147 50 644 H | Tip fixed/Lower fixed PTO manual disengage | 147 50 644 HK | 12 bar | 5 bar |
| 147 50 650 H | Tip fixed/Lower fixed PTO auto disengage | 147 50 650 HK | 12 bar | 5 bar |
| 147 50 652 H | Tip spring/Lower fixed PTO auto disengage | 147 50 652 HK | 12 bar | 5 bar |
| 147 50 600 | Seal kit for proportional control | | | |

*All ports 6mm push **Kit includes 6mm airline x 20m

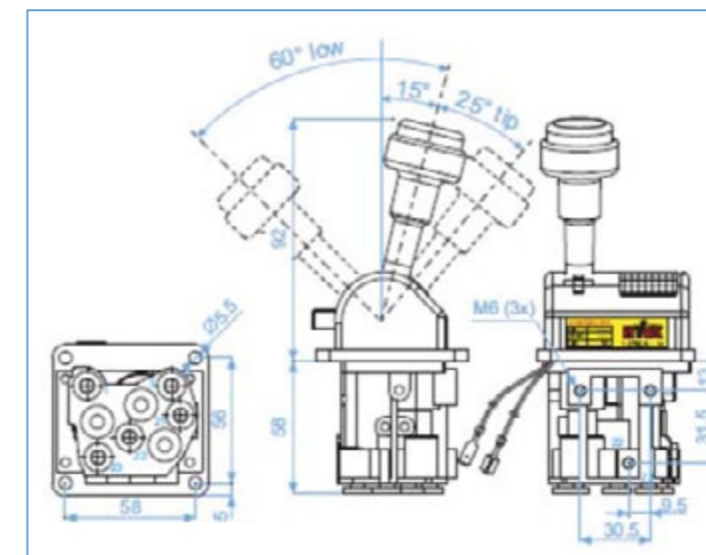

Connections
 1 : air inlet
 3 : air exhaust
 21 : lowering connection (to tipping valve)
 22 : tipping connection (to tipping valve)
 23 : working port P.T.O.



Support Brackets for Proportional Tip Controls

| Part no. | Description |
|-------------|-----------------------------|
| 092 05 002 | 90° bracket for tip control |
| 092 32 002 | 45° bracket for tip control |
| 147 52 532H | Enclosed box complete kit |



| Small Control box and Lid | |
|--|------------------|
| Part no. | Description |
| BOXB | L180xW120xH140mm |
| Fits 1 x joystick and 2 -3 bank switches | |

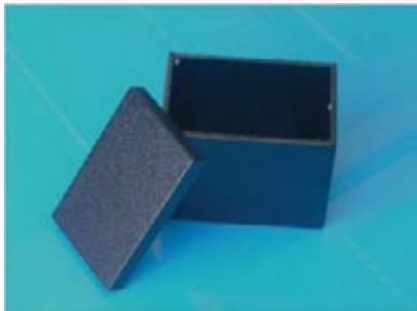

| Large Control box (Floor Mounted) | |
|-----------------------------------|-----------------------|
| Part no. | Description |
| BOXA | Box L300xW120xH300 |
| BOXLIDA | Blank lid L300 x W120 |

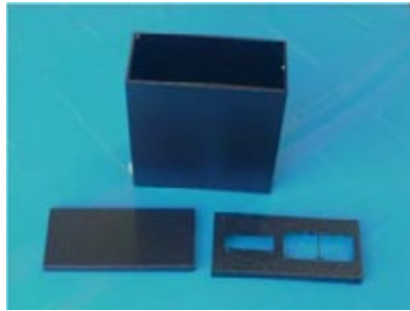

Fits 2 x joystick and 2-3 bank switches

ENQUIRE ABOUT PRE-CUT LIDS

Multi Section Flange Mounted Air Switch

This range of flange mounted air controls is designed to feed pneumatically controlled equipment. They are easy to mount, have one single air inlet and exhaust directly into the atmosphere.

| Part no. | Description | Kit no.** | Max Pressure | Min Pressure |
|--|--------------------------------|---------------|--------------|--------------|
| 147 50 210 H | 1 bank – fixed with light | 147 50 210 HK | 12 bar | 5 bar |
| 147 50 230 H | 2 bank – fixed with light | 147 50 230 HK | 12 bar | 5 bar |
| 147 50 250 H | 3 bank – fixed with light | 147 50 250 HK | 12 bar | 5 bar |
| 147 50 270 H | 4 bank – fixed with light | 147 50 270 HK | 12 bar | 5 bar |
| 147 50 601 | Seal kit for multi bank switch | | | |
| *all ports M12 x 1.25 ** kit includes 6mm airline x 20m and air fittings | | | | |

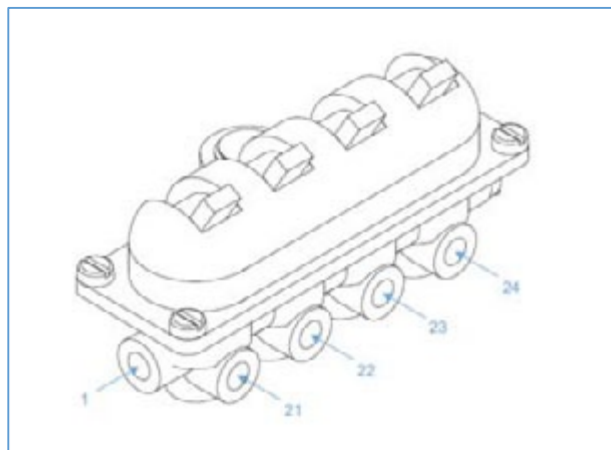

1 : air inlet
21 : working port 1
22 : working port 2
23 : working port 3
24 : working port 4



Multi Section Proportional Tip Controls

| Part no. | Description | Pos. | Max. press. (bar) | Min. press. (bar) | Ports | | | |
|------------|--|------|-------------------|-------------------|-------|------|------|------|
| | | | | | (A) | (B) | (P) | (R) |
| 147 50 430 | Tip control flat model MS-air-TF/LF | 1 | 12 bar | 5 bar | 6 mm | 6 mm | 6 mm | 6 mm |
| 147 50 455 | Tip control flat model-air-3/2 section | 2 | 12 bar | 5 bar | 6 mm | - | - | - |
| 147 50 460 | Tip control flat model-air-4/3 section | 3 | 12 bar | 5 bar | 6 mm | 6 mm | - | - |

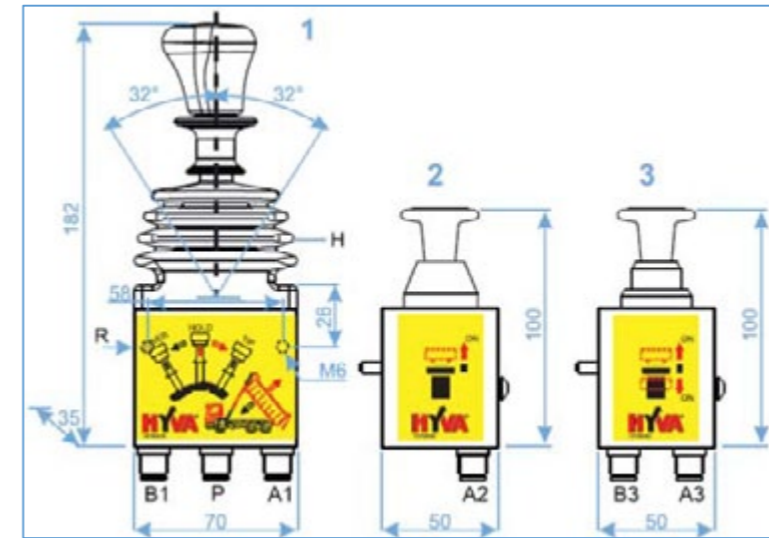

P : air inlet
R : air exhaust
H : rubber for handle
A1 : tipping connection (to tipping valve)
B1 : lowering connection (to tipping valve)

A2 : working port additional 3/2 section
A3 : working port additional 4/3 section
B3 : working port additional 4/3 section



Mounting kit for multi sections

| Part no. | Description |
|------------|---------------------------------------|
| 147 50 511 | Mounting kit for one extra section |
| 147 50 512 | Mounting kit for two extra sections |
| 147 50 513 | Mounting kit for three extra sections |



Electronic Tip Controls

Magtronic Switch Kits

| Part no. | Description |
|-----------|-------------------------------|
| 021417100 | Switch kit 12v PTO Only |
| 021417102 | Switch kit 12v PTO & Valve |
| 021417200 | Switch kit 24v PTO Only |
| 021417202 | Switch kit 24v PTO & Valve |
| 32101002 | Magtronic PTO Actuator 12/24v |



Complete Kit Includes:

- *PTO switch
- *Valve Switch
- *Warning Lights
- *30A Battery fuse
- *Body Up Alarm w/bracket
- *Pressure switch
- *Harness to suit Magtronic PTO

“Electric Over Air” Controls

Hyva Pacific supplies “Electric over Air” Control kits, Electronic controls in the cab, Air controlled hydraulic equipment. This type of control system is becoming more popular in European manufactured trucks.

Included in these kits:

- * Genuine/Non Genuine Switches that fit into the empty slots on the dash
- * PTO switch and harness that is integrated into the computer
- * Electric over air solenoids
- * All wiring/All Airline and fittings
- * Air piloted hose burst Valve

Call Hyva Pacific to Enquire about **Electric over air** controls.

Air Tip Controls Accessories

| 6mm tube push fittings | |
|------------------------|--------------------|
| Part no. | Description |
| SWT2L01007 | 1/8" BSP straight |
| SWTFJG04 | 1/8" BSP 90° elbow |
| SWT2L01C08 | 1/4" BSP straight |
| SWTF06 | 1/4" BSP 90° elbow |



| 6mm tube screw fittings | |
|-------------------------|----------------------|
| Part no. | Description |
| 01915290H | M12 x 1.25 straight |
| 01915307H | M12 x 1.25 90° elbow |
| 01915315H | 1/8" BSPT straight |
| 01968572H | 1/8" BSPT 90° elbow |



| 6mm push joiners | |
|------------------|--------------------|
| Part no. | Description |
| SWT2L11003 | Bulkhead |
| SWT2019003 | Joiner |
| SWT2L46002 | F – M 90° elbow |
| SWT146MM | F1/4" tube to M6mm |



| Tee Joiners | |
|-------------|-----------------------|
| Part no. | Description |
| 09225005 | 6mm tee |
| 09225010 | Tee F/F/F 1/8" BSPT |
| SWT2L32008 | Tee 6mm x 2 1/8" BSPT |



| 6mm Airline | |
|-------------|-------------|
| Part no. | Description |
| SWTAIR06MM | 10m roll |



| Electric over Air | |
|-------------------|--------------------|
| Part no. | Description |
| SWTE-305.M1 | Housing 1/8" ports |
| SWTE-DINPLUG | Din Plug |
| 12vdc solenoid | SWTE-MB4 |
| 24vdc solenoid | SWTE-MB5 |



| Pneumatic Pressure indicator | |
|------------------------------|----------------------------|
| Part no. | Description |
| 09225010 | T-piece pneumatic 3 x 1/8" |
| 01964000H | Control light |
| 01964001H | Pressure switch 1/8" |



| Pneumatic Knock-off | |
|---------------------|---------------------------|
| Part no. | Description |
| 14700506 | Knock-off with bracket |
| 14700508 | Knock-off without bracket |



| Pneumatic hose burst valve | |
|----------------------------|-----------------|
| Part no. | Description |
| VLV-118181 | Ports 1/8" BSPT |



Hyva Tipping Cylinders

Hyva is the world's No.1 producer of hydraulic tipping cylinders for the commercial vehicle industry. Hyva designs and manufactures a complete range of telescopic tipping cylinders, both for front-end and underbody applications. The new Hyva cylinder is lightweight, uses less oil and therefore tips and lowers faster and is strong, stable and maintenance free.

Hyva front-end cylinder range

The standard Hyva cylinder range includes Front-End Cylinders with Outer Cover (FC) and well mount with Eye (FE). Double acting cylinders are also available. Tipping capacity ranges up to 90 tons. In addition to our standard features, Hyva offers options such as dual oil inlet and several surface treatments. The piston of each front-end cylinder is hard chromed.

The standard front-end range consists of cylinders with a diameter of 80 to 238 mm and a stroke ranging from 2700 to 9500 mm.

Hyva under body cylinder range

Hyva also produces a complete range of under body cylinders. The heavy duty series are offered up to diameter 223 mm with nine stages. The UCB-series starts at diameter 76 mm with two stages.

Modular design

Thanks to the modular design Hyva can offer a complete range of tipping cylinders assembled to order. Our flexible manufacturing is your best guarantee for a minimum delivery time for the standard range of cylinders. The use of top quality materials keeps wear at a minimum and maintenance simple. For service no special tools are required.

Quality

All Hyva cylinders are fully tested before dispatch (pressure tests up to 1½ times working pressure). Our customers all over the world acknowledge our reliability. The ISO 9001 standard held since 1991 is your assurance of optimum quality, safety and professionalism.

After sales service

Whatever the age of your equipment and wherever it is working, Hyva's world-wide service network will support you. In case of technical trouble you will be back on the road in no time.

Modification

Hyva Pacific has a fully equipped workshop, and can modify hoists to suit all truck and trailer applications. Some of the modifications we perform are:

- De-strokes
- Foot mount modifications
- Raised trunnion
- Clevis modifications
- Complete hoist resizing

Code system tipping cylinders

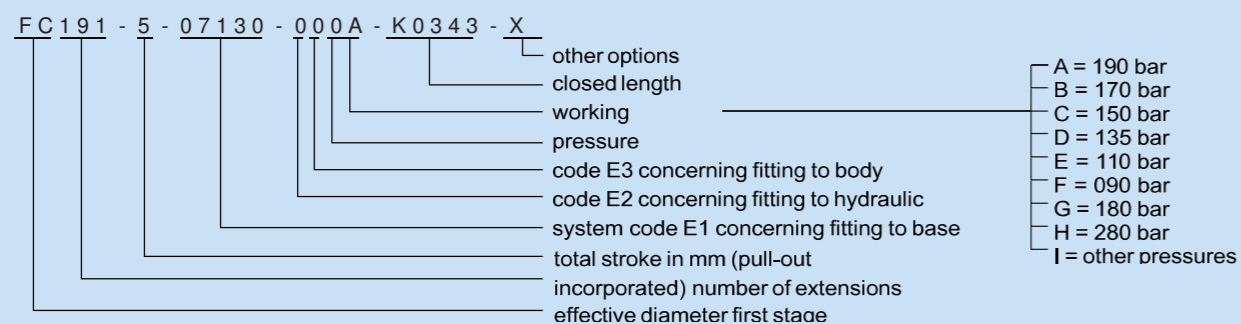

Flash hoist – FE Series

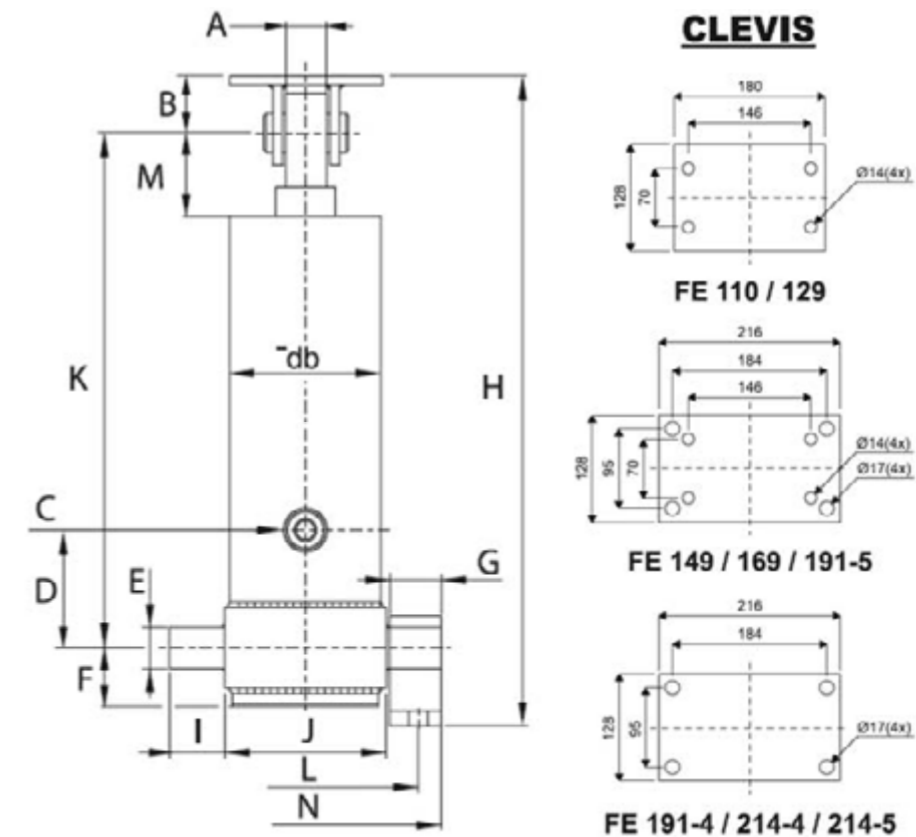

| Part Number | Hoist Model | No of Stages | Stroke mm | Capacity at 150 Bar | Weight, incl. F/M and test oil | Vol. litres | Closed Ht H* | N | L STD F/M | C |
|-------------|-----------------|--------------|-----------|---------------------|--------------------------------|-------------|--------------|-----|-----------|--------|
| 71533112 | FE 110-3-2755 | 3 | 2755 | 20T | 99 Kg | 21 | 1399 | 303 | 237x95 | 1" SAE |
| 71533162 | FE 110-3-3205 | 3 | 3205 | 20T | 108 Kg | 24 | 1549 | 303 | 237x95 | 1" SAE |
| 71533182 | FE 110-3-3460 | 3 | 3460 | 20T | 122 Kg | 26 | 1634 | 303 | 237x95 | 1" SAE |
| 71534112 | FE 129-3-2755 | 3 | 2755 | 28T | 120 Kg | 30 | 1399 | 341 | 237x95 | 1" SAE |
| 71534132 | FE 129-3-2980 | 3 | 2980 | 28T | 126 Kg | 32 | 1474 | 341 | 237x95 | 1" SAE |
| 71534164 | FE 129-3-3205 | 3 | 3205 | 28T | 139 Kg | 34 | 1549 | 341 | 237x95 | 1" SAE |
| 71534182 | FE 129-3-3460 | 3 | 3460 | 28T | 146 Kg | 37 | 1634 | 341 | 237x95 | 1" SAE |
| 71534184 | FE 129-3-3460RT | 3 | 3460 | 28T | 146 Kg | 37 | 1470 | 341 | 237x95 | 1" SAE |
| 71534186 | FE 129-4-3680 | 4 | 3680 | 25T | 138 Kg | 34 | 1399 | 341 | 237x95 | 1" SAE |
| 71534202 | FE 129-3-3700 | 3 | 3700 | 28T | 152 Kg | 40 | 1714 | 341 | 237x95 | 1" SAE |
| 71534222 | FE 129-3-3880 | 3 | 3880 | 28T | 159 Kg | 42 | 1794 | 341 | 237x95 | 1" SAE |
| 71534232 | FE 129-3-3880RT | 3 | 3880 | 28T | 159 Kg | 42 | 1609 | 341 | 237x95 | 1" SAE |
| 71534172 | FE 129-4-3380 | 4 | 3380 | 25T | 134 Kg | 34 | 1324 | 341 | 237x95 | 1" SAE |
| 71535232 | FE 149-4-3980 | 4 | 3980 | 35T | 162 Kg | 51 | 1474 | 341 | 237x95 | 1" SAE |
| 71535242 | FE 149-3-4090 | 3 | 4090 | 40T | 184 Kg | 59 | 1864 | 341 | 237x95 | 1" SAE |
| 71535262 | FE 149-4-4280 | 4 | 4280 | 35T | 171 Kg | 55 | 1549 | 341 | 237x95 | 1" SAE |
| 71535292 | FE 149-4-4620 | 4 | 4620 | 35T | 180 Kg | 59 | 1634 | 341 | 237x95 | 1" SAE |
| 71535392 | FE 149-4-5180 | 4 | 5180 | 35T | 198 Kg | 66 | 1794 | 341 | 237x95 | 1" SAE |
| 71535482 | FE 149-4-6100 | 4 | 6100 | 30T | 235 Kg | 78 | 2054 | 341 | 237x95 | 1" SAE |
| 71536394 | FE 169-4-5180 | 4 | 5180 | 40T | 247 Kg | 88 | 1814 | 405 | 341x165 | 1" SAE |
| 71536452 | FE 169-4-5460 | 4 | 5460 | 40T | 256 Kg | 92 | 1884 | 405 | 341x165 | 1" SAE |
| 71536472 | FE 169-4-5700 | 4 | 5700 | 40T | 264 Kg | 96 | 1944 | 405 | 341x165 | 1" SAE |
| 71536482 | FE 169-4-6100 | 4 | 6100 | 40T | 281 Kg | 103 | 2074 | 405 | 341x165 | 1" SAE |
| 71536532 | FE 169-4-6500 | 4 | 6500 | 40T | 295 Kg | 110 | 2174 | 405 | 341x165 | 1" SAE |
| 71536492 | FE 169-5-6180 | 5 | 6180 | 35T | 265 Kg | 93 | 1734 | 405 | 341x165 | 1" SAE |
| 71537642 | FE 191-4-7220 | 4 | 7220 | 50T | 395 Kg | 158 | 2387 | 405 | 341x165 | 1" SAE |
| 71537492 | FE 191-5-6180 | 5 | 6180 | 55T | 315 Kg | 122 | 1737 | 405 | 341x165 | 1" SAE |
| 71537524 | FE 191-5-6480 | 5 | 6480 | 55T | 320 Kg | 127 | 1817 | 405 | 341x165 | 1" SAE |
| 71537584 | FE 191-5-7130 | 5 | 7130 | 55T | 343 Kg | 140 | 1932 | 405 | 341x165 | 1" SAE |
| 71537720 | FE 191-5-8130 | 5 | 8130 | 55T | 383 Kg | 160 | 2162 | 405 | 341x165 | 1" SAE |
| 71538642 | FE 214-4-7220 | 4 | 7220 | 70T | 468 Kg | 202 | 2382 | 450 | 376x216 | 1" SAE |
| 71538586 | FE 214-5-7130 | 5 | 7130 | 60T | 405 Kg | 180 | 1947 | 450 | 376x216 | 1" SAE |
| 71538732 | FE 214-5-8130 | 5 | 8130 | 60T | 453 Kg | 205 | 2177 | 450 | 376x216 | 1" SAE |

FE top clevis

| Part no. | Description | Hole Pattern | Contents |
|------------|--|-------------------------|--------------------------|
| 015 06 787 | FE top bracket 110/129 | 146 x 70mm | Includes Pin and spacers |
| 015 06 785 | FE top bracket 149/169/191-5 | 146 x 70mm & 184 x 95mm | Includes Pin and spacers |
| 015 06 789 | FE top bracket 191-4/214-4/214-501506789 | 184 x 95mm | Includes Pin and spacers |

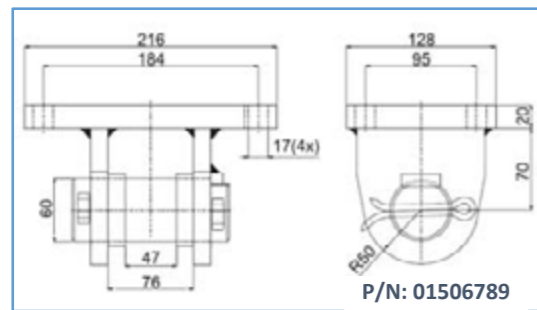
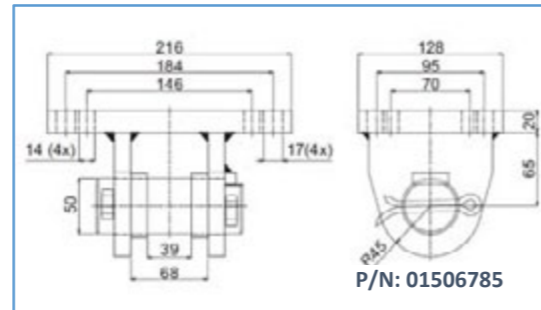
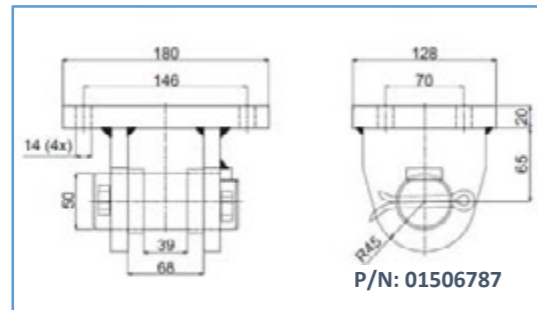

FE/FC Foot mounts

| Part no. | Cylinder Range | Bolt Hole Pattern | A | B | C | D | Hole | width |
|-------------|----------------|----------------------------------|-----|-----|-----|----|------|-------|
| 015 06 500 | 110 | 237 x 95mm | 100 | 95 | 150 | 17 | 60 | 70 |
| 015 06 502 | 129-149 | 237 x 95mm | 100 | 95 | 150 | 17 | 60 | 70 |
| 015 06 506R | 149 | 305 x 165mm | 125 | 165 | 220 | 20 | 60 | 80 |
| 015 06 506 | 169-191 | 341 x 165mm | 125 | 165 | 220 | 20 | 60 | 80 |
| 015 06 507 | 169 | 305 x 165mm | 125 | 165 | 220 | 20 | 60 | 80 |
| 015 06 508 | 191 | 376 x 216mm (if replacing FE207) | 125 | 216 | 275 | 26 | 60 | 90 |
| 015 06 510 | 214 | 376 x 216mm | 140 | 216 | 275 | 26 | 65 | 90 |
| 015 06 490 | Suit 60mm pin | Low Profile FM drilled to suit | 55 | NA | 220 | NA | 60 | 80 |

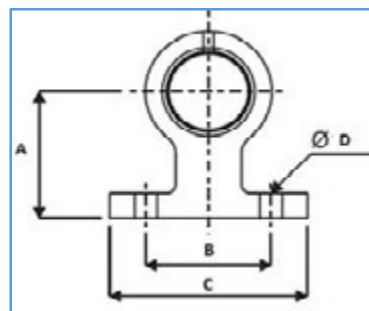

P/N: 01506500 - 502

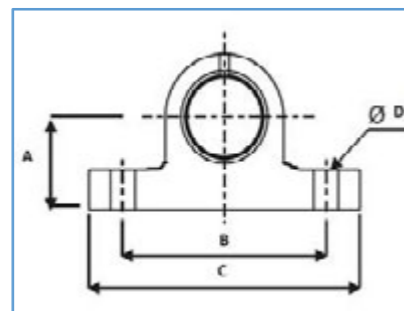

P/N: 01506490

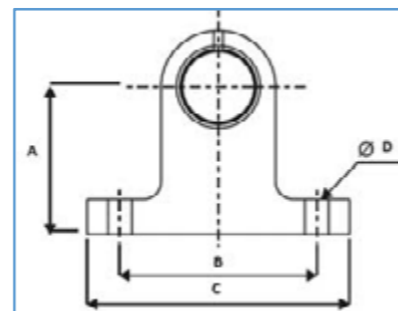

P/N: 01506506 - 510

Flash hoist – FC Series Shroud

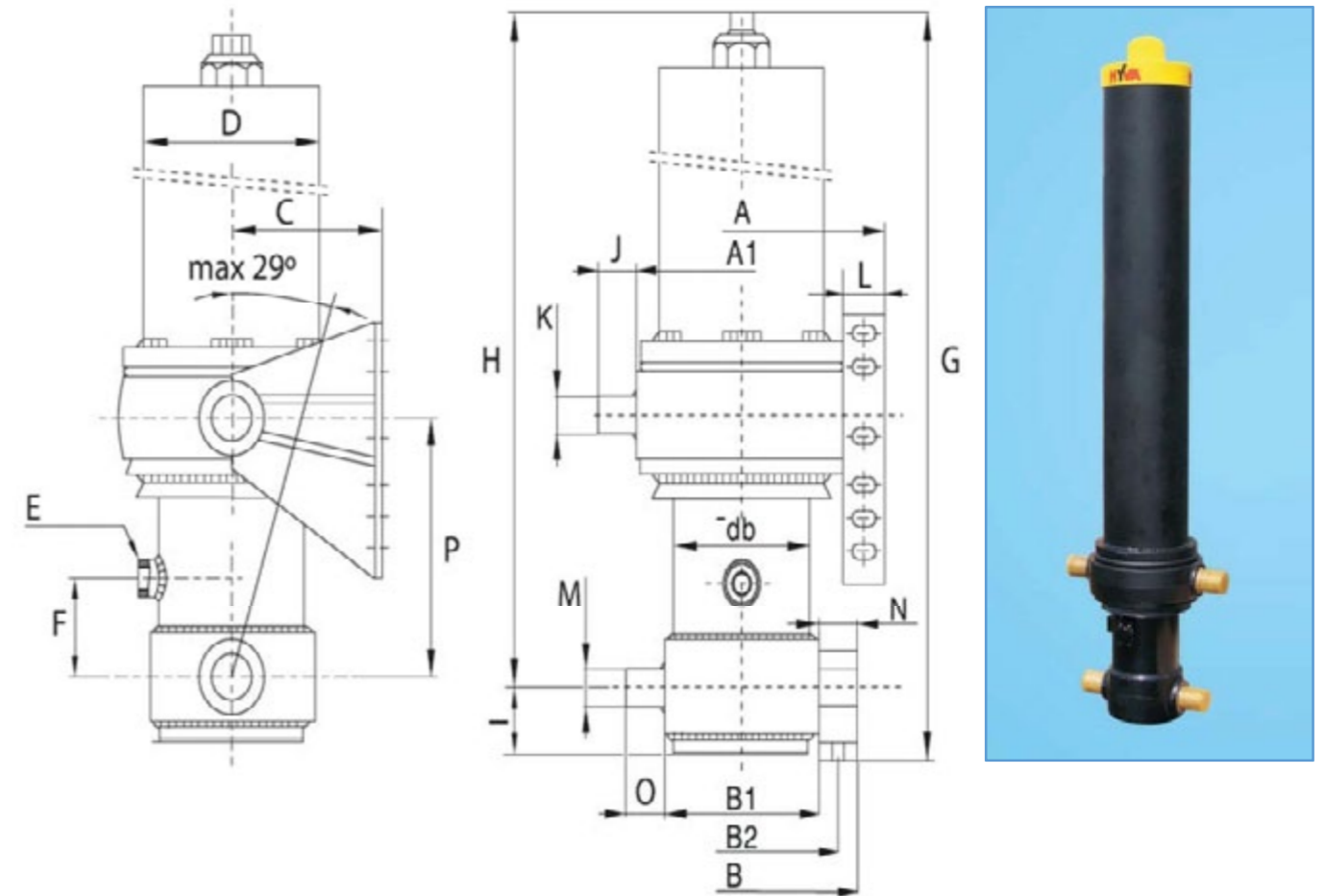

| Part Number | Hoist Model | No of Stages | Stroke mm | Capacity at 150 Bar | Weight, incl. footmounts and test oil | Total Volume litres | Closed Ht G* Mm | P | B STD F/M | E |
|-------------|---------------|--------------|-----------|---------------------|---------------------------------------|---------------------|-----------------|-----|-----------|--------|
| 714 91 240 | FC 093-3-3245 | 3 | 3245 | 15 T | 104 Kg | 18 | 1382 | 343 | 276 | 1" SAE |
| 715 03 160 | FC 110-3-3205 | 3 | 3205 | 20 T | 138 Kg | 24 | 1499 | 343 | 303 | 1" SAE |
| 715 03 180 | FC 110-3-3460 | 3 | 3460 | 20 T | 145 Kg | 26 | 1584 | 343 | 303 | 1" SAE |
| 715 04 180 | FC 129-3-3460 | 3 | 3460 | 28 T | 208 Kg | 37 | 1584 | 343 | 341 | 1" SAE |
| 715 04 220 | FC 129-3-3880 | 3 | 3880 | 28 T | 225 Kg | 42 | 1734 | 343 | 341 | 1" SAE |
| 715 04 262 | FC 129-4-4280 | 4 | 4280 | 25 T | 212 Kg | 40 | 1399 | 343 | 341 | 1" SAE |
| 715 04 290 | FC 129-4-4620 | 4 | 4620 | 25 T | 222 Kg | 43 | 1484 | 343 | 341 | 1" SAE |
| 715 05 292 | FC 149-4-4620 | 4 | 4620 | 35 T | 257 Kg | 59 | 1484 | 343 | 341 | 1" SAE |
| 715 05 404 | FC 149-4-5180 | 4 | 5180 | 35 T | 280 Kg | 66 | 1694 | 343 | 341 | 1" SAE |
| 715 06 390 | FC 169-4-5180 | 4 | 5180 | 40 T | 328 Kg | 88 | 1719 | 343 | 405 | 1" SAE |
| 715 06 540 | FC 169-4-6500 | 4 | 6500 | 40 T | 386 Kg | 110 | 2124 | 343 | 405 | 1" SAE |
| 715 06 580 | FC 169-5-7130 | 5 | 7130 | 35 T | 371 Kg | 107 | 1884 | 343 | 405 | 1" SAE |
| 715 07 716 | FC 191-5-8130 | 5 | 8130 | 55 T | 489 Kg | 160 | 2127 | 343 | 405 | 1" SAE |

*) Closed height includes 20 mm pull-out

FC Hoist lifting brackets

| Part no. | Description | Kg |
|------------|----------------------------------|-----|
| 015 09 120 | Lifting bracket right FC 110/129 | 6,5 |
| 015 09 121 | Lifting bracket left FC 110/129 | 6,5 |

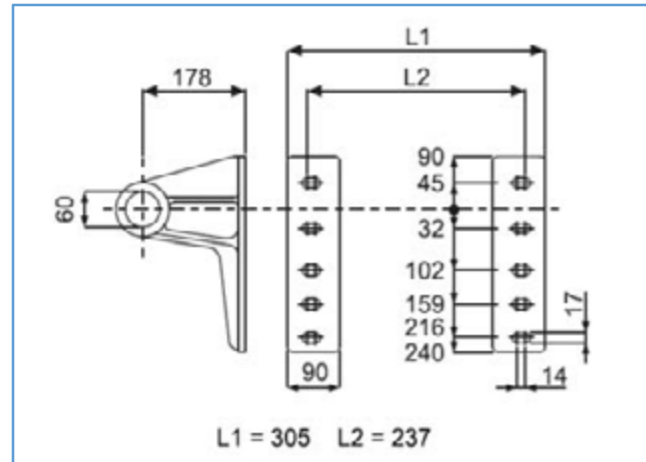

| Part no. | Description | Kg |
|------------|--|-----|
| 015 09 130 | Lifting bracket right FC 129/149/169/191 | 9,5 |
| 015 09 131 | Lifting bracket left FC 129/149/169/191 | 9,5 |

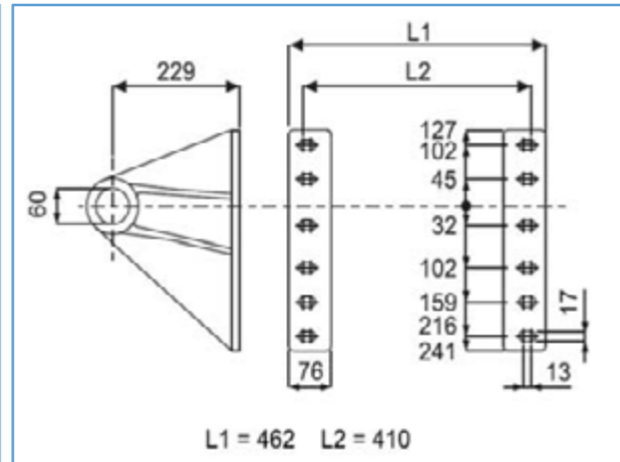

FC Top Nuts

| Part no. | Description | key width |
|--------------|-------------------------------|-----------|
| 017 02 890 K | Top nut and washer - FC - M48 | 75mm |
| 017 02 920 K | Top nut and washer - FC - M39 | 60mm |



Bearing Bushes

| Part no. | Description | øID mm | øOD mm | L mm |
|--------------|--------------------------|--------|--------|------|
| 017 94 210 | Bearing bush (500 – 508) | 60 | 65 | 50 |
| 017 94 240 | Bearing bush (510) | 65 | 70 | 50 |
| 562 9000 124 | Bronze bush (500 – 508) | 60 | 65 | 60 |
| TBC | Bronze bush (510) | 65 | 70 | 60 |

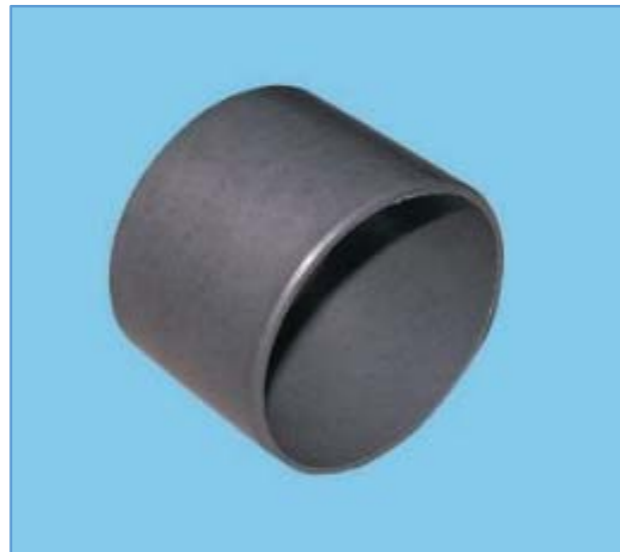

Seal kits complete FE/FC hoists

| Cylinder | Part no. | Description |
|---------------|--------------|-------------------------------|
| FC 080 - 3 | 017 62 380 K | Seal kit complete FC 080-3 |
| FC/FE 091 - 3 | 719 01 230 K | Seal kit complete FC/FE 091-3 |
| FC/FE 110 - 3 | 719 01 330 K | Seal kit complete FC/FE 110-3 |
| FC/FE 129 - 3 | 719 01 430 K | Seal kit complete FC/FE 129-3 |
| FC/FE 129 - 4 | 719 01 440 K | Seal kit complete FC/FE 129-4 |
| FC/FE 149 - 3 | 719 01 430 K | Seal kit complete FC/FE 149-3 |
| FC/FE 149 - 4 | 719 01 540 K | Seal kit complete FC/FE 149-4 |
| FC/FE 149 - 5 | 719 01 550 K | Seal kit complete FC/FE 149-5 |
| FC/FE 169 - 4 | 719 01 640 K | Seal kit complete FC/FE 169-4 |
| FC/FE 169 - 5 | 719 01 650 K | Seal kit complete FC/FE 169-5 |
| FC/FE 191 - 4 | 719 01 740 K | Seal kit complete FC/FE 191-4 |
| FC/FE 191 - 5 | 719 01 750 K | Seal kit complete FC/FE 191-5 |
| FC/FE 191 - 6 | 719 01 760 K | Seal kit complete FC/FE 191-6 |
| FC/FE 214 - 5 | 719 01 850 K | Seal kit complete FC/FE 214-5 |
| FC/FE 214 - 6 | 719 01 860 K | Seal kit complete FC/FE 214-6 |



Flash Cylinder Caps

| Part no. | Description |
|------------|-----------------------------|
| 718 38 945 | Cylinder cap FE/FEE 110 |
| 718 38 950 | Cylinder cap FE/FEE 129 |
| 718 38 955 | Cylinder cap FE/FEE 149 |
| 718 38 960 | Cylinder cap FE/FEE 169 |
| 718 38 965 | Cylinder cap FE/FEE 191-5/6 |
| 718 38 970 | Cylinder cap FE/FEE 214-5 |
| 718 38 975 | Cylinder cap FE/FEE 214-6/7 |
| 718 38 983 | Dust ring base FE 169-5 |
| 718 38 984 | Dust ring base FE 191-5/6 |
| 017 02 973 | Cylinder cap FC 129 |
| 017 02 972 | Cylinder cap FC 149/169 |
| 017 02 971 | Cylinder cap FC 191/214 |



UCB Underbody hoists

Model number breakdown

| UCB | 76 | 2 | 0610 |
|-----------|--------------------------------|---------------|--------|
| Underbody | 1 st stage diameter | No. of stages | Stroke |

| Part No. | Model | Cap. | Vol. | A | B | C | D | E | F | G | H | I |
|------------|--------------------|------|------|-----|----|-----|-----|----|-----|-----|----|-----|
| 014 03 035 | UCB 76-2-0595 | 5t | 2.3 | 115 | 40 | 170 | 95 | 35 | 310 | 480 | 55 | 95 |
| 014 03 270 | UCB 76-3-0790 | 5t | 2.5 | 115 | 40 | 142 | 95 | 35 | 275 | 417 | 45 | 112 |
| 014 04 258 | UCB 107-4-01710 | 10t | 10 | 150 | 40 | 157 | 124 | 40 | 445 | 622 | 55 | 95 |
| 014 04 272 | UCB 107-4-01990 | 10t | 11 | 150 | 40 | 157 | 124 | 40 | 515 | 672 | 55 | 95 |
| 014 04 027 | UCB 107-4-0830 | 10t | 5 | 150 | 40 | 157 | 124 | 40 | 225 | 402 | 55 | 95 |
| 014 04 209 | UCB 107-4-01510 | 10t | 7.5 | 150 | 40 | 157 | 124 | 40 | 340 | 552 | 55 | 95 |
| 014 04 367 | UCB 107-5-01040 | 8t | 5 | 150 | 40 | 150 | 124 | 40 | 225 | 375 | 45 | 112 |
| 014 04 375 | UCB 107-5-01490 | 8t | 7.5 | 150 | 40 | 150 | 124 | 40 | 315 | 465 | 45 | 112 |
| 014 04 395 | UCB 107-6-01000 | 6t | 4.5 | 150 | 40 | 150 | 124 | 40 | 185 | 335 | 45 | 112 |
| 014 04 397 | UCB 107-6-01245 | 6t | 5.5 | 150 | 40 | 150 | 124 | 40 | 225 | 395 | 45 | 112 |
| 014 04 390 | UCB 107-6-0840 | 6t | 3.6 | 150 | 40 | 140 | 124 | 40 | 155 | 295 | 45 | 112 |
| 014 04 368 | UCB 107-5-01190 | 8t | 6 | 150 | 40 | 150 | 124 | 40 | 255 | 405 | 45 | 112 |
| 014 04 556 | UCB 126-5-01230 | 11t | 9 | 175 | 45 | 165 | 152 | 45 | 265 | 430 | 55 | 95 |
| 014 04 659 | UCB 126-5-01480 | 11t | 11 | 175 | 45 | 165 | 152 | 45 | 315 | 480 | 55 | 95 |
| 014 04 702 | UCB 126-5-01880 | 11t | 13.5 | 175 | 45 | 165 | 152 | 45 | 395 | 560 | 55 | 95 |
| 014 04 805 | UCB 126-5-02130 | 11t | 15.5 | 175 | 45 | 155 | 152 | 45 | 450 | 605 | 55 | 115 |
| 014 04 806 | UCB 127-5-02130 HC | 11t | 15.5 | 175 | 45 | 155 | 152 | 45 | 450 | 605 | 55 | 115 |
| 014 04 825 | UCB 126-5-02480 | 11t | 18 | 175 | 45 | 165 | 152 | 45 | 515 | 700 | 55 | 95 |
| 014 07 135 | UCB 126-6-01180 | 9t | 7.1 | 175 | 45 | 155 | 152 | 45 | 215 | 390 | 45 | 112 |
| 014 07 150 | UCB 126-6-01480 | 9t | 8.9 | 175 | 45 | 155 | 152 | 45 | 265 | 420 | 45 | 112 |
| 014 07 155 | UCB 126-6-01780 | 9t | 11.2 | 175 | 45 | 155 | 152 | 45 | 315 | 490 | 45 | 112 |
| 014 07 180 | UCB 126-6-02977 | 9t | 19 | 175 | 45 | 155 | 152 | 45 | 515 | 670 | 45 | 112 |
| 014 09 486 | UCB 145-6-01765 | 13t | 15.6 | 210 | 45 | 240 | 170 | 50 | 240 | 480 | 55 | 95 |
| 014 09 488 | UCB 165-6-01540 | 20t | 18.5 | 230 | 45 | 268 | 190 | 50 | 210 | 478 | 65 | 107 |
| 014 09 500 | UCB 165-6-01810 | 20t | 21.5 | 230 | 45 | 268 | 190 | 50 | 255 | 523 | 65 | 107 |
| 014 09 803 | UCB 165-6-02950 | 20t | 34.6 | 230 | 45 | 268 | 190 | 50 | 445 | 713 | 65 | 107 |

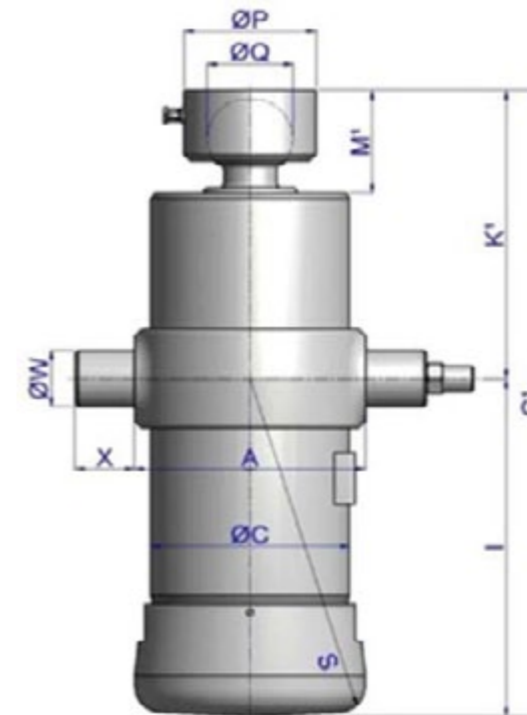
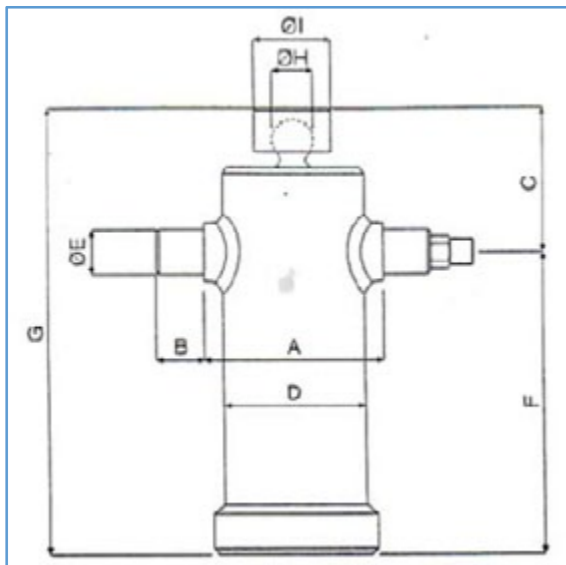

Hyva Flash Underbody hoists

Model number breakdown

| ULB | 077 | 2 | 0610 | K170 | 40 | ½" | HC |
|-----------|--------------------------------|---------------|--------|-------|----------|-----------|-------------|
| Underbody | 1 st stage diameter | No. of stages | Stroke | K dim | Pin size | Port size | Hard chrome |

| Part No | Model | Cap | Wt (Kg) | Vol (L) | A | C | I | G | M | P | Q | X |
|------------|--------------------------------|-----|---------|---------|-----|-----|-----|-----|-----|-----|----|----|
| 714 16 175 | ULB 077-2-0610-K170-40-1/2"-HC | 5t | 14 | 2.7 | 115 | 91 | 340 | 510 | 87 | 88 | 53 | 40 |
| 714 16 217 | ULB 077-2-0770-K170-40-1/2"-HC | 5t | 20 | 3.4 | 115 | 91 | 420 | 590 | 87 | 88 | 53 | 40 |
| 714 18 237 | ULB 110-4-0825-K177-40-1/2"-HC | 10t | 26 | 5.5 | 150 | 129 | 236 | 413 | 87 | 88 | 53 | 40 |
| 714 18 439 | ULB 110-4-1545-K177-40-1/2"-HC | 10t | 38 | 10.3 | 150 | 129 | 416 | 593 | 87 | 88 | 53 | 40 |
| 714 18 297 | ULB 110-5-1040-K169-40-1/2"-HC | 8t | 28 | 6 | 150 | 129 | 236 | 405 | 79 | 80 | 45 | 40 |
| 714 18 441 | ULB 110-5-1540-K169-40-1/2"-HC | 8t | 36 | 8.8 | 150 | 129 | 336 | 505 | 79 | 80 | 45 | 40 |
| 714 18 349 | ULB 110-5-1240-K169-40-1/2"-HC | 8t | 32 | 7.1 | 150 | 129 | 276 | 445 | 79 | 80 | 45 | 40 |
| 714 04 365 | UMB 129-5-1280-K192-45-1/2"-HC | 11t | 53 | 10 | 175 | 149 | 276 | 468 | 86 | 88 | 53 | 45 |
| 714 04 421 | UMB 129-5-1480-K192-45-1/2"-HC | 11t | 57 | 11.6 | 175 | 149 | 316 | 508 | 86 | 88 | 53 | 45 |
| 714 04 537 | UMB 129-5-1880-K192-45-1/2"-HC | 11t | 66 | 14.7 | 175 | 149 | 396 | 588 | 86 | 88 | 53 | 45 |
| 714 04 567 | UMB 129-5-1980-K192-45-1/2"-HC | 11t | 45 | 7.4 | 175 | 149 | 256 | 468 | 86 | 88 | 53 | 45 |
| 714 04 659 | UMB 129-5-2280-K192-45-1/2"-HC | 11t | 76 | 17.8 | 175 | 149 | 490 | 682 | 86 | 88 | 53 | 45 |
| 714 04 709 | UMB 129-5-2480-K192-45-1/2"-HC | 11t | 81 | 19.4 | 175 | 149 | 530 | 722 | 86 | 88 | 53 | 45 |
| 714 05 509 | UMB 149-6-1780-K245-50-3/4"-HC | 13t | 73 | 17.2 | 205 | 169 | 267 | 512 | 86 | 88 | 53 | 45 |
| 714 06 537 | UMB 169-5-1880-K265-50-3/4"-HC | 22t | 95 | 28.1 | 230 | 191 | 347 | 612 | 107 | 110 | 75 | 45 |
| 714 06 439 | UMB 169-6-1540-K258-50-3/4"-HC | 20t | 79 | 20.3 | 230 | 191 | 227 | 485 | 99 | 100 | 65 | 45 |
| 714 06 509 | UMB 169-6-1780-K258-50-3/4"-HC | 20t | 86 | 23.5 | 230 | 191 | 267 | 525 | 99 | 100 | 65 | 45 |
| 714 06 852 | UMB 169-6-2980-K258-50-3/4"-HC | 20t | 119 | 39.4 | 230 | 191 | 481 | 739 | 99 | 100 | 65 | 45 |
| 714 07 691 | UMB 191-6-2380-K270-60-3/4"-HC | 24t | 129 | 41.7 | 245 | 214 | 379 | 649 | 106 | 110 | 75 | 45 |

UCE Underbody hoists (Bottom Trunnion)

Model number breakdown

| UCE | 76 | 2 | 0595 | LT |
|-----------|--------------------------------|---------------|--------|--------------|
| Underbody | 1 st stage diameter | No. of stages | Stroke | Low trunnion |

| Part No | Model | Cap | Vol | A | B | C | D | E | G | H | I |
|------------|--------------------|-----|-----|-----|----|----|-----|----|-----|----|----|
| 014 03 038 | UCE 076-2-0595 LT | 5t | 2.3 | 115 | 45 | 30 | 95 | 45 | 438 | 52 | 31 |
| 014 06 705 | UCE 107-4-01190 LT | 10t | 7 | 150 | 45 | 30 | 124 | 45 | 412 | 32 | 31 |
| 014 06 707 | UCE 107-4-01300 LT | 10t | 7.5 | 150 | 45 | 30 | 124 | 45 | 452 | 32 | 31 |
| 014 06 700 | UCE 107-4-01510 LT | 10t | 8.8 | 150 | 45 | 30 | 124 | 45 | 497 | 32 | 31 |
| 014 06 710 | UCE 107-4-01710 LT | 10t | 10 | 150 | 45 | 30 | 124 | 45 | 557 | 32 | 31 |
| 014 06 715 | UCE 107-4-01990 LT | 10t | 11 | 150 | 45 | 30 | 124 | 45 | 640 | 32 | 31 |

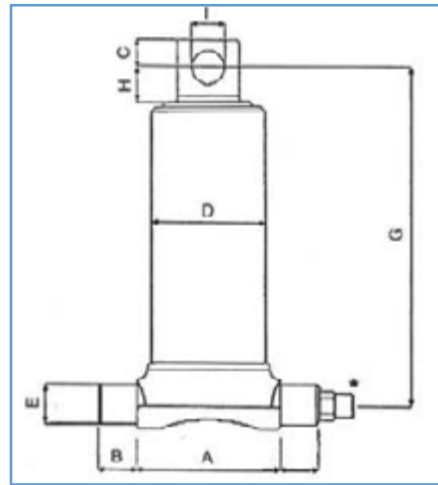

Foot mounts UCB/UCE Underbody series

| Part no. | Description | ØR | S | T | U | V | W | ØX |
|------------|---------------|----|-----|-----|----|----|----|----|
| 014 14 501 | FM-UCB/UCE-35 | 35 | 91 | 117 | 40 | 8 | 24 | 8 |
| 014 14 550 | FM-UCB/UCE-40 | 40 | 100 | 141 | 45 | 14 | 32 | 15 |
| 014 14 604 | FM-UCB/UCE-45 | 45 | 105 | 141 | 45 | 14 | 35 | 15 |
| 014 14 653 | FM-UCB/UCE-50 | 50 | 120 | 155 | 50 | 17 | 38 | 15 |

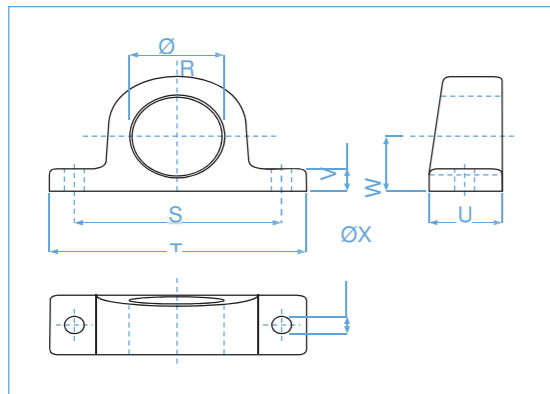

Foot mounts FLASH Underbody series

| Part no. | Description | ØR | S | T | U | V | W | ØX |
|------------|-----------------|----|-----|-----|----|----|----|----|
| 731 05 071 | FM-FLASH-ULB-40 | 40 | 100 | 141 | 45 | 14 | 32 | 15 |
| 731 05 073 | FM-FLASH-UMB-45 | 45 | 105 | 141 | 45 | 14 | 35 | 15 |
| 731 05 076 | FM-FLASH-UMB-50 | 50 | 120 | 155 | 50 | 17 | 38 | 15 |

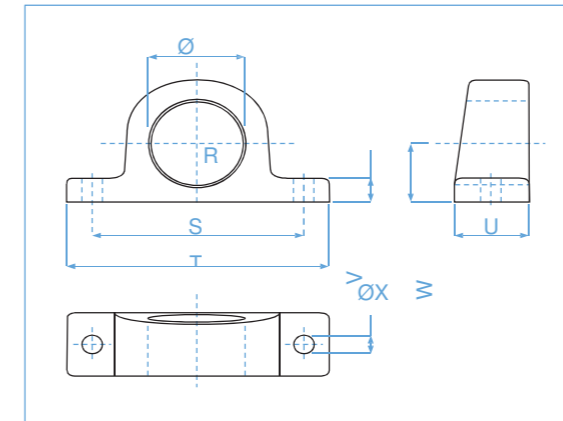

3 way tipping cradles for UCB/FLASH hoists

| Part no. | Description | J (mm) | K (mm) | L (mm) | ØM (mm) | N (mm) | O (mm) | ØP (mm) | Q (°) | Weight (kg) |
|------------|--------------------|--------|--------|--------|---------|--------|--------|---------|-------|-------------|
| 731 04 021 | UM Cradle 129 | 280 | 180 | 135 | 45 | 35 | 40 | 50 | 60 | 12.6 |
| 731 04 031 | UM Cradle 149 | 330 | 210 | 152 | 50 | 37 | 40 | 50 | 60 | 19.7 |
| 731 04 041 | UM Cradle 169 | 380 | 235 | 162 | 50 | 37 | 40 | 50 | 60 | 25.1 |
| 731 04 033 | UM Cradle 149 k.o. | 330 | 210 | 152 | 50 | 37 | 40 | 50 | 60 | 27.7 |
| 731 04 043 | UM Cradle 169 k.o. | 380 | 235 | 162 | 50 | 37 | 40 | 50 | 60 | 33.0 |

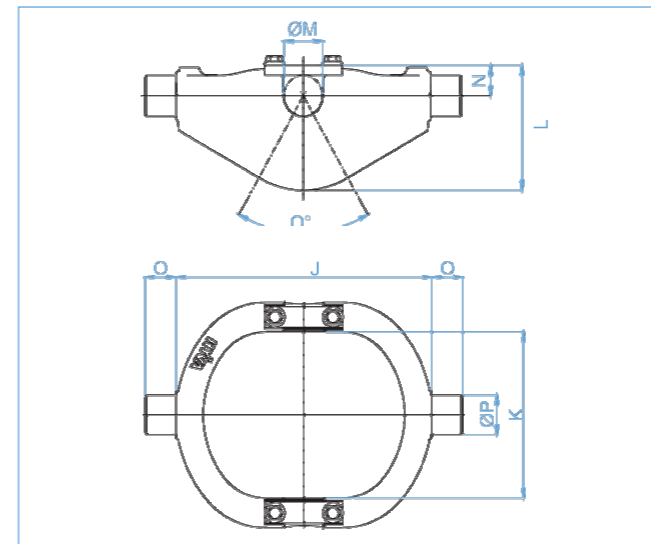

Seal kits UCB/UCE Underbody hoists

| Part no. | Description |
|------------|-------------------------|
| 016 02 120 | Seal kit complete 107-4 |
| 016 02 122 | Seal kit complete 107-6 |
| 016 02 123 | Seal kit complete 107-5 |
| 016 02 128 | Seal kit complete 126-5 |
| 016 02 129 | Seal kit complete 126-6 |
| 016 02 144 | Seal kit complete 145-6 |
| 016 02 154 | Seal kit complete 165-6 |

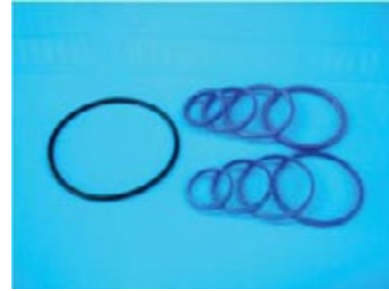

Seal kits Flash underbody hoists

| Part no. | Description |
|-------------|-------------------------|
| 719 06 620k | Seal kit complete 077-2 |
| 719 06 840k | Seal kit complete 110-4 |
| 719 06 850k | Seal kit complete 110-5 |
| 719 06 450k | Seal kit complete 129-5 |
| 719 04 560k | Seal kit complete 149-6 |
| 719 04 650k | Seal kit complete 169-5 |
| 719 04 660k | Seal kit complete 169-6 |
| 719 04 761k | Seal kit complete 191-6 |



Oil inlet nipple UCB/UCE

| Part no. | Description |
|------------|--------------------------------------|
| 016 01 450 | Oil inlet nipple UM 1/2" - M18 x 1,5 |
| 016 01 600 | Oil inlet nipple UM 3/4" - M22 x 1,5 |



Oil inlet nipple FLASH

| Part no. | Description |
|------------|--|
| 731 03 000 | Oil inlet nipple FLASH UM 1/2" - M18 x 1,5 |
| 731 03 002 | Oil inlet nipple FLASH UM 3/4" - M22 x 1,5 |



Tipping Accessories

HYFIX Body lock

The Hyfix locks the tipper body to the chassis, reducing travel noise, and reducing wear of truck components such as the cylinder, pivot hinges, tipper body and chassis. It is available in steel or aluminium.

| Part no. | Description |
|-------------|-----------------------------------|
| 081 02 855 | Hyfix-set steel incl. bracket |
| 081 02 867 | Hyfix-set aluminium incl. bracket |
| 081 02 864T | Hyfix steel excl. bracket |
| 081 02 890T | Hyfix aluminium excl. bracket |
| 148 97 167T | Hyfix bracket steel |
| 148 97 168 | Hyfix bracket aluminium |

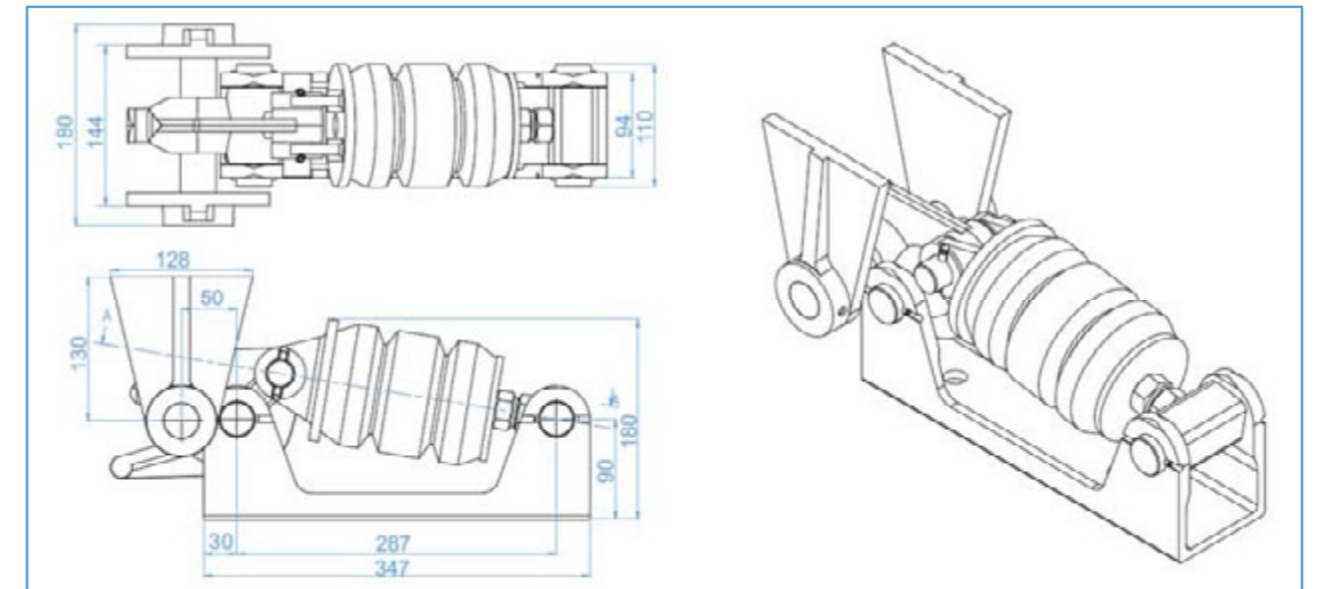

Polyp Gripping Device

The polyp grip has the same function as the hyfix but for smaller tippers. These are ideal for 2 or 3 way tippers. This product restrains the tipper body on poor road conditions. Available in steel or aluminium.

| Part no. | Description |
|--|-------------------------------------|
| 081 01 000 | Polyp rubber set complete |
| 081 01 012 | Polyp rubber - rubber with base nut |
| 081 01 024 | Polyp rubber - cup steel |
| 081 01 036 | Polyp rubber - pin steel |
| 081 01 037 | Polyp rubber - pin aluminium |
| 100 kg force req. to close and open polyps. | |



Electronic Slope Detector

The slope detector gives a visual and audible signal as soon as the vehicle gets too much side slope during the tipping cycle.

| Part no. | Description |
|------------|--|
| 147 42 200 | Slope detector kit complete Inc: Display Unit Sensor module Wiring harness 20m Instruction Manual |



Kit complete



Display Unit

Hoses and Fittings

Hyva Pacific Can supply Hydraulic hoses, cut to length, and fittings to suit any of our hydraulic products. Hose sizes/pressures and hose end types other than displayed below are available on request.

Pressure Hose

| Part no. (Sold per metre) | Hose Description | Hose ends BSP female swivel Part no. | | | |
|------------------------------|------------------|--------------------------------------|--------------|----------------|----------------|
| | | Ferrule | Straight | 45° | 90° |
| HOS-846AA010 | 3/8" max 330 bar | FIT-FNP-06 | FIT-SFB-0606 | FIT-SFB45-0606 | FIT-SFB90-0606 |
| HOS-846AA01200 | 1/2" max 275 bar | FIT-FNP-08 | FIT-SFB-0808 | FIT-SFB45-0808 | FIT-SFB90-0808 |
| HOS-846AA02000 | 3/4" max 213 bar | FIT-FNP-12 | FIT-SFB-1212 | FIT-SFB45-1212 | FIT-SFB90-1212 |
| HOS-846AA02500 | 1" max 165 bar | FIT-FNP-16 | FIT-SFB-1616 | FIT-SFB45-1616 | FIT-SFB90-1616 |





Suction Hose

| Part no. (Sold per metre) | Hose description | Hose clamp Part no. |
|------------------------------|-------------------|---------------------|
| HOS-605AA019 | 3/4" max 26 bar | FIT-SP32-35 |
| HOS-605AA025 | 1" max 20 bar | FIT-SP37-40 |
| HOS-605AA032/R | 1 1/4" max 15 bar | FIT-SP43-47 |
| HOS-605AA038 | 1 1/2" max 11 bar | FIT-SP47-51 |
| HOS-605AA051 | 2" max 7 bar | FIT-SP60-63 |



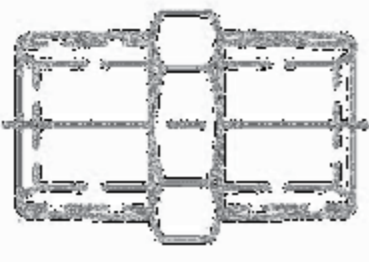
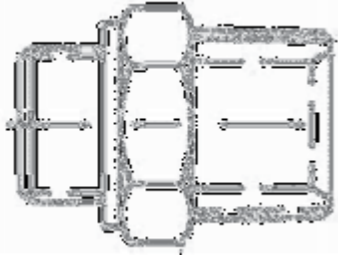
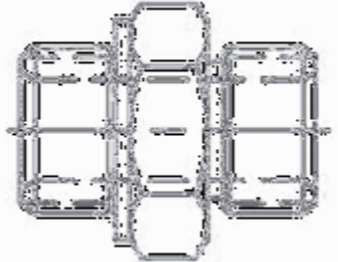
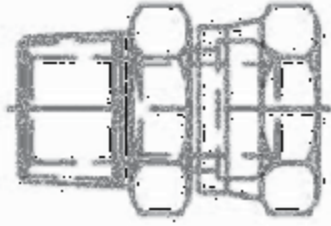

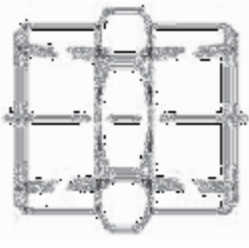
Hydraulic fittings - Nipples

|  | |  | |  | |
|---|-----------------|---|---------------|---|-----------------|
| Nipple M/M BSPT x BSPT | | Nipple M/M BSPP x BSPT | | Nipple M/M BSPP x BSPP | |
| Part no. | Description | Part no. | Description | Part no. | Description |
| FIT-CB1-0202 | 1/8" x 1/8" | FIT-CPB1-0404 | 1/4" x 1/4" | FIT-CP1-0202 | 1/8" x 1/8" |
| FIT-CB1-0402 | 1/4" x 1/8" | FIT-CPB1-0604 | 3/8" x 1/4" | FIT-CP1-0404 | 1/4" x 1/4" |
| FIT-CB1-0404 | 1/4" x 1/4" | FIT-CPB1-0406 | 1/4" x 3/8" | FIT-CP1-0604 | 3/8" x 1/4" |
| FIT-CB1-0604 | 3/8" x 1/4" | FIT-CPB1-0606 | 3/8" x 3/8" | FIT-CP1-0606 | 3/8" x 3/8" |
| FIT-CB1-0606 | 3/8" x 3/8" | FIT-CPB1-0804 | 1/2" x 1/4" | FIT-CB1-0806 | 1/2" x 3/8" |
| FIT-CB1-0804 | 1/2" x 1/4" | FIT-CPB1-0806 | 1/2" x 3/8" | FIT-CB1-0808 | 1/2" x 1/2" |
| FIT-CB1-0806 | 1/2" x 3/8" | FIT-CPB1-0808 | 1/2" x 1/2" | FIT-CB1-1208 | 3/4" x 1/2" |
| FIT-CB1-0808 | 1/2" x 1/2" | FIT-CPB1-1208 | 3/4" x 1/2" | FIT-CB1-1212 | 3/4" x 3/4" |
| FIT-CB1-1208 | 3/4" x 1/2" | FIT-CPB1-0812 | 1/2" x 3/4" | FIT-CB1-1608 | 1" x 1/2" |
| FIT-CB1-1212 | 3/4" x 3/4" | FIT-CPB1-1212 | 3/4" x 3/4" | FIT-CB1-1612 | 1" x 3/4" |
| FIT-CB1-1608 | 1" x 1/2" | FIT-CPB1-1608 | 1" x 1/2" | FIT-CB1-1616 | 1" x 1" |
| FIT-CB1-1612 | 1" x 3/4" | FIT-CPB1-1612 | 1" x 3/4" | FIT-CB1-2016 | 1 1/4" x 1" |
| FIT-CB1-1616 | 1" x 1" | FIT-CPB1-1216 | 3/4" x 1" | FIT-CP1-2020 | 1 1/4" x 1 1/4" |
| FIT-CB1-2016 | 1 1/4" x 1" | FIT-CPB1-1616 | 1" x 1" | | |
| FIT-CB1-2416 | 1 1/2" x 1" | FIT-CPB1-2016 | 1 1/4" x 1" | | |
|  | |  | |  | |
| ST Union M/F BSPT x BSPP | | Red' Bush M/F BSPT x BSPT | | Socket F/F BSPT x BSPT | |
| Part no. | Description | Part no. | Description | Part no. | Description |
| FIT-CB24-0404 | 1/4" x 1/4" | FIT-CB73-0402 | 1/4" x 1/8" | FIT-CB9-0202 | 1/8" x 1/8" |
| FIT-CB24-0606 | 3/8" x 3/8" | FIT-CB73-0602 | 3/8" x 1/8" | FIT-CB9-0402 | 1/4" x 1/8" |
| FIT-CB24-0608 | 3/8" x 1/2" | FIT-CB73-0604 | 3/8" x 1/4" | FIT-CB9-0404 | 1/4" x 1/4" |
| FIT-CB24-0806 | 1/2" x 3/8" | FIT-CB73-0802 | 1/2" x 1/8" | FIT-CB9-0604 | 3/8" x 1/4" |
| FIT-CB24-0808 | 1/2" x 1/2" | FIT-CB73-0804 | 1/2" x 1/4" | FIT-CB9-0606 | 3/8" x 3/8" |
| FIT-CB24-1212 | 3/4" x 3/4" | FIT-CB73-0806 | 1/2" x 3/8" | FIT-CB9-0804 | 1/2" x 1/4" |
| FIT-CB24-1216 | 3/4" x 1" | FIT-CB73-1204 | 3/4" x 1/4" | FIT-CB9-0806 | 1/2" x 3/8" |
| FIT-CB24-1616 | 1" x 1" | FIT-CB73-1206 | 3/4" x 3/8" | FIT-CB9-0808 | 1/2" x 1/2" |
| FIT-CB24-1620 | 1" x 1 1/4" | FIT-CB73-1208 | 3/4" x 1/2" | FIT-CB9-1208 | 3/4" x 1/2" |
| FIT-CB24-1624 | 1" x 1 1/2" | FIT-CB73-1608 | 1" x 1/2" | FIT-CB9-1212 | 3/4" x 3/4" |
| FIT-CB24-2020 | 1 1/4" x 1 1/4" | FIT-CB73-1612 | 1" x 3/4" | FIT-CB9-1612 | 1" x 3/4" |
| | | FIT-CB73-2012 | 1 1/4" x 3/4" | FIT-CB9-1616 | 1" x 1" |
| | | FIT-CB73-2016 | 1 1/4" x 1" | FIT-CB9-2020 | 1 1/4" x 1 1/4" |
| | | FIT-CB73-2416 | 1 1/2" x 1" | FIT-CB9-2424 | 1 1/2" x 1 1/2" |

*Other type adaptors (ie JIC, Metric etc) available on request

Hydraulic fittings - joiners

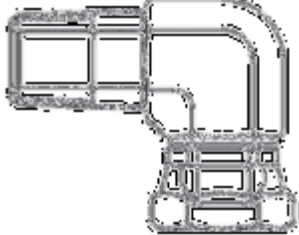
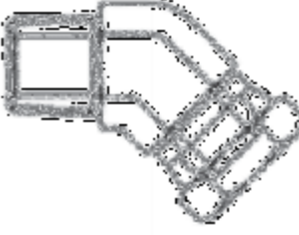
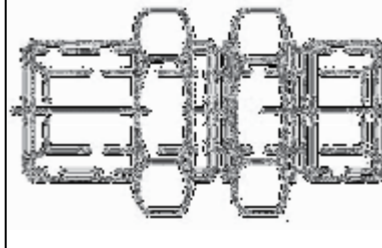
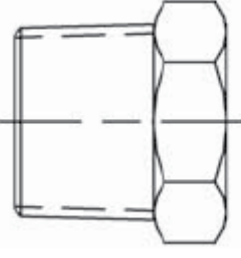
|  | |  | |  | |
|---|-----------------|---|-----------------|---|-----------------|
| 90° Elbow M/M BSPT x BSPT | | 90° Elbow M/M BSPP x BSPT | | 90° Union M/F BSPT x BSPP | |
| Part no. | Description | Part no. | Description | Part no. | Description |
| FIT-CB53-0202F | 1/8" x 1/8" | FIT-CPB53-0404F | 1/4" x 1/4" | FIT-CB46-0202F | 1/8" x 1/8" |
| FIT-CB53-0402F | 1/4" x 1/8" | FIT-CPB53-0604F | 3/8" x 1/4" | FIT-CB46-0404F | 1/4" x 1/4" |
| FIT-CB53-0404F | 1/4" x 1/4" | FIT-CPB53-0406F | 1/4" x 3/8" | FIT-CB46-0406F | 1/4" x 3/8" |
| FIT-CB53-0604F | 3/8" x 1/4" | FIT-CPB53-0606F | 3/8" x 3/8" | FIT-CB46-0604F | 3/8" x 1/4" |
| FIT-CB53-0606F | 3/8" x 3/8" | FIT-CPB53-0608F | 3/8" x 1/2" | FIT-CB46-0606F | 3/8" x 3/8" |
| FIT-CB53-0804F | 1/2" x 1/4" | FIT-CPB53-0806F | 1/2" x 3/8" | FIT-CB46-0608F | 3/8" x 1/2" |
| FIT-CB53-0806F | 1/2" x 3/8" | FIT-CPB53-0808F | 1/2" x 1/2" | FIT-CB46-0806F | 1/2" x 3/8" |
| FIT-CB53-0808F | 1/2" x 1/2" | FIT-CPB53-0812F | 1/2" x 3/4" | FIT-CB46-0808F | 1/2" x 1/2" |
| FIT-CB53-1208F | 3/4" x 1/2" | FIT-CPB53-1212F | 3/4" x 3/4" | FIT-CB46-1208F | 3/4" x 1/2" |
| FIT-CB53-1212F | 3/4" x 3/4" | FIT-CPB53-1612F | 1" x 3/4" | FIT-CB46-1212F | 3/4" x 3/4" |
| FIT-CB53-1612F | 1" x 3/4" | FIT-CPB53-1616F | 1" x 1" | FIT-CB46-1616F | 1" x 1" |
| FIT-CB53-1616F | 1" x 1" | FIT-CPB53-2020F | 1 1/4" x 1 1/4" | FIT-CB46-2020 | 1 1/4" x 1 1/4" |
| FIT-CB53-2012F | 1 1/4" x 3/4" | FIT-CPB53-2424F | 1 1/2" x 1 1/2" | FIT-CB46-2424 | 1 1/2" x 1 1/2" |
| FIT-CB53-2016F | 1 1/4" x 1" | | | | |
| FIT-CB53-2020F | 1 1/4" x 1 1/4" | | | | |
|  | |  | |  | |
| 45° Union M/F BSPT x BSPP | | Bulkhead M/M BSPP x BSPP | | Plug BSPT | |
| Part no. | Description | Part no. | Description | Part no. | Description |
| FIT-CB30-0202F | 1/8" x 1/8" | FIT-CP6-0404 | 1/4" x 1/4" | FIT-CB77-02 | 1/8" |
| FIT-CB30-0404F | 1/4" x 1/4" | FIT-CP6-0606 | 3/8" x 3/8" | FIT-CB77-04 | 1/4" |
| FIT-CB30-0606F | 3/8" x 3/8" | FIT-CP6-0808 | 1/2" x 1/2" | FIT-CB77-06 | 3/8" |
| FIT-CB30-0808F | 1/2" x 1/2" | FIT-CP6-1212 | 3/4" x 3/4" | FIT-CB77-08 | 1/2" |
| FIT-CB30-1212F | 3/4" x 3/4" | FIT-CP6-1616 | 1" x 1" | FIT-CB77-12 | 3/4" |
| FIT-CB30-1616F | 1" x 1" | FIT-CP6-2020 | 1 1/4" x 1 1/4" | FIT-CB77-16 | 1" |
| FIT-CB30-2020F | 1 1/4" x 1 1/4" | | | FIT-CB77-20 | 1 1/4" |
| | | | | FIT-CB77-24 | 1 1/2" |

*Other type adaptors (ie JIC, Metric etc) available on request

Hydraulic Fittings – hose tails

| Suction Hose M/M BSPT | | Suction Hose 90° M/M BSPT | | Tee M/M/M BSPT x 3 | |
|-----------------------|-----------------|---------------------------|-----------------|--------------------|--------------------------|
| Part no. | Description | Part no. | Description | Part no. | Description |
| FIT-C60-1212 | 3/4" x 3/4" | FIT-CB60-1212 | 3/4" x 3/4" | FIT-CB62-020202F | 1/8" x 1/8" x 1/8" |
| FIT-CB4-1616 | 1" x 1" | FIT-CB60-1216 | 3/4" x 1" | FIT-CB62-040404F | 1/4" x 1/4" x 1/4" |
| FIT-CB4-1620 | 1" x 1 1/4" | FIT-CB60-1616 | 1" x 1" | FIT-CB62-060606F | 3/8" x 3/8" x 3/8" |
| FIT-CB4-1624 | 1" x 1 1/2" | FIT-CB60-1620 | 1" x 1 1/4" | FIT-CB62-080808F | 1/2" x 1/2" x 1/2" |
| FIT-CB4-2016 | 1 1/4" x 1" | FIT-CB60-1624 | 1" x 1 1/2" | FIT-CB62-121212F | 3/4" x 3/4" x 3/4" |
| FIT-CB4-2020 | 1 1/4" x 1 1/4" | FIT-CB60-2016 | 1 1/4" x 1" | FIT-CB62-161616F | 1" x 1" x 1" |
| FIT-CB4-2024 | 1 1/4" x 1 1/2" | FIT-CB60-2020 | 1 1/4" x 1 1/4" | FIT-CB62-202020 | 1 1/4" x 1 1/4" x 1 1/4" |
| FIT-CB4-2420 | 1 1/2" x 1 1/4" | FIT-CB60-2024 | 1 1/4" x 1 1/2" | FIT-CB62-242424 | 1 1/2" x 1 1/2" x 1 1/2" |
| FIT-CB4-2424 | 1 1/2" x 1 1/2" | FIT-CB60-2420 | 1 1/2" x 1 1/4" | FIT-CB62-323232 | 2" x 2" x 2" |
| FIT-CB4-2432 | 1 1/2" x 2" | FIT-CB60-2424 | 1 1/2" x 1 1/2" | | |
| FIT-CB4-3232 | 2" x 2" | FIT-CB60-2432 | 1 1/2" x 2" | | |
| FIT-CB4-3240 | 2" x 2 1/2" | FIT-CB60-3232 | 2" x 2" | | |

*Other type adaptors (ie JIC, Metric etc) available on request

Others

| Bonded Seal | | Hose Clamps | | Hydraulic oil grade 68 | |
|-------------|--------------------|-------------|-------------|------------------------|-------------|
| Part no. | Description | Part no. | Description | Part no. | Description |
| FIT-D04 | 1/4" bonded seal | FIT-SP32-35 | 32-35mm | hydraulic oil | Per litre |
| FIT-D06 | 3/8" bonded seal | FIT-SP34-37 | 34-37mm | VAL2174-20 | 20L Drum |
| FIT-D08 | 1/2" bonded seal | FIT-SP37-40 | 37-40mm | | |
| FIT-D12 | 3/4" bonded seal | FIT-SP40-43 | 40-43mm | | |
| FIT-D16 | 1" bonded seal | FIT-SP44-47 | 44-47mm | | |
| FIT-D20 | 1 1/4" bonded seal | FIT-SP47-51 | 47-51mm | | |
| FIT-D24 | 1 1/2" bonded seal | FIT-SP55-59 | 55-59mm | | |
| | | FIT-SP60-63 | 60-63mm | | |
| | | FIT-SP63-68 | 63-68mm | | |
| | | FIT-SP68-73 | 68-73mm | | |
| | | FIT-SP73-79 | 73-79mm | | |

Quick Release Couplings

| TEMA 1/2" BSPP QRC | | TEMA 3/4" BSPP QRC | | TEMA 1" BSPP QRC | |
|--------------------|--------------------|--------------------|--------------------|------------------|------------------|
| Part no. | Description | Part no. | Description | Part no. | Description |
| QRC C 0500 | 1/2" Tema Complete | QRC C 0750 | 3/4" Tema Complete | QRC C 1000T | 1" Tema Complete |
| QRC M 0500 | 1/2" Tema Male | QRC M 0750 | 3/4" Tema Male | QRC M 1000 | 1" Tema Male |
| QRC DC 0500 | 1/2" dust cover | QRC DC 0750 | 3/4" dust cover | QRC DC 1000 | 1" dust cover |
| QRC F 0500 | 1/2" Tema Female | QRC F 0750 | 3/4" Tema Female | QRC F 1000 | 1" Tema Female |
| QRC DP 0500 | 1/2" Dust plug | QRC DP 0750 | 3/4" Dust plug | QRC DP 1000 | 1" Dust plug |
| QRC SK 0500 | 1/2" seal kit | QRC SK 0750 | 3/4" seal kit | QRC SK 1000 | 1" seal kit |

*other Quick release couplings available on request



Towing Hitches & Body Hardware

Hyva Pacific is the NSW distributor for **Wallace Forge** pintle hooks.

Wallace forge has been developing quality products in the trucking industry since 1942, and is a consistent market leader. All products are manufactured in the USA. The Wallace Forge catalogue consists of pintle hooks (from 1t – 40t), drawbar eyes, king-pins, dual purpose hitches, hide away tow bars, tow rings and more.

All Wallace forge components are tested and certified to **ISO 9001:2008**.



Hyva Pacific stocks selected **V. Orlandi** couplings, the E520 range (50mm drawbar eye), that is compatible with other brands with an ISO fitting pattern. V. Orlandi's Pacific series couplings are manufactured in Italy and the Pacific series are specifically designed for the Australian market.

V. Orlandi couplings are fitted as standard by some of the world's biggest trailer manufacturers.



Hyva Pacific also stocks **body hardware** components, consisting of rear pivot kits and side swing kits for small to medium tippers and draw bar landing gear.

King Pins

Forged out of an AISI 8630 or 4320 material, depending on the model, Wallace Forge's King Pins conform to all SAE and AAR standards. Every one of our King Pins is 100% Brinell hardness checked, magnetic particle inspected and weldable.

Standard SAE dimensional tolerances apply to all dimensions. King Pins are made from 8630 Alloy steel and heat treated to 302-363 Brinell, unless otherwise stated.

Wallace Forge King Pins will hold approximately 15 000 PSI ultimate and 115 PSI yield strength. All King Pins are 100% Brinell hardness checked, magnetic particle inspected and weldable.

"A" Style King Pins

*made from 8630 Alloy Steel

*Available in 4320H Steel

*Also known as Mushroom King Pins

| Part No. | Model | Dimensions | | | | | W. |
|----------|---------|------------|-------|--------|--------|--------|-----|
| | | A | B | C | D | E | |
| 2084194 | KP-38-A | 0.38-0.58" | 0.38" | 1.289" | 2.755" | 3.305" | 7kg |
| 2084195 | KP-50-A | 0.38-0.58" | 0.5" | 1.289" | 2.755" | 3.305" | 7kg |

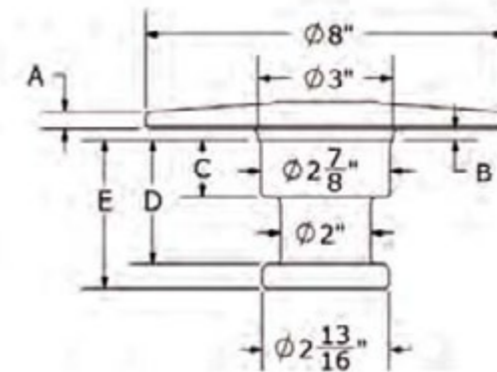

Wallace Forge King Pins are not for off road equipment. The use of a lube plate alters the King Pin dimensions from SAE standards and may prevent proper coupling.

3 1/2" Heavy Duty King Pins

*made from 8630 Alloy Steel

*Heat treated to Brinell 302-363

*These King Pins are for off road equipment and heavy duty trucks

*Drilled models feature 4 x 1.25" holes on a diameter of 8.5"

| Part No. | Model | Bolster plate thickness (B) | W |
|----------|-------------------|-----------------------------|--------|
| 2393162 | KP 848-38 | 0.38" | 19.5kg |
| 2394163 | KP 848-50 | 0.50" | 19.5kg |
| 2393162D | KP 848-38 drilled | 0.38" | 19kg |
| 2394163D | KP 848-50 drilled | 0.50" | 19kg |

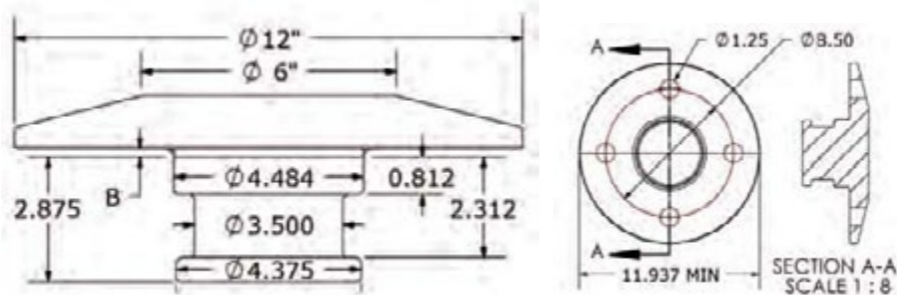

King Pin Locks

*The king pin lock comes with 2 keys, specify key number

*Lunette lock does not come with lock and key

| Part No. | Model | Description | W |
|----------|---------------|---------------------------|-------|
| 2084164 | King pin lock | Ø ID 73.6mm length 89mm | 1.7kg |
| 2405176 | Lunette lock | Fits 63.5mm to 76.2mm eye | 1.8kg |



King pin lock



Lunette lock

Swivel Mounted Pintle Hooks

| Part No. | Model | Max Capacity | | W |
|----------|----------|--------------|------|------|
| | | G.T.W | V.L | |
| 2048105 | B15 d=6t | 15t | 1.5t | 13kg |
| 2049106 | B25 d=9t | 25t | 3t | 13kg |

15 ton replacement parts

| Part no. | Description |
|----------|---|
| 2089176 | 15 ton latch ass. |
| 2097187 | Cushion spring |
| 2102189 | Mounting brackets (pair) |
| 2099178 | 15 ton snapper pin, s hook, chain & latches |

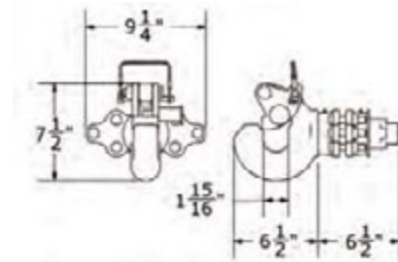

25 ton replacement parts

| Part no. | Description |
|----------|---|
| 2090177 | 25 ton latch ass. |
| 2097187 | Cushion spring |
| 2102189 | Mounting brackets (pair) |
| 2099179 | 25 ton snapper pin, s hook, chain & latches |

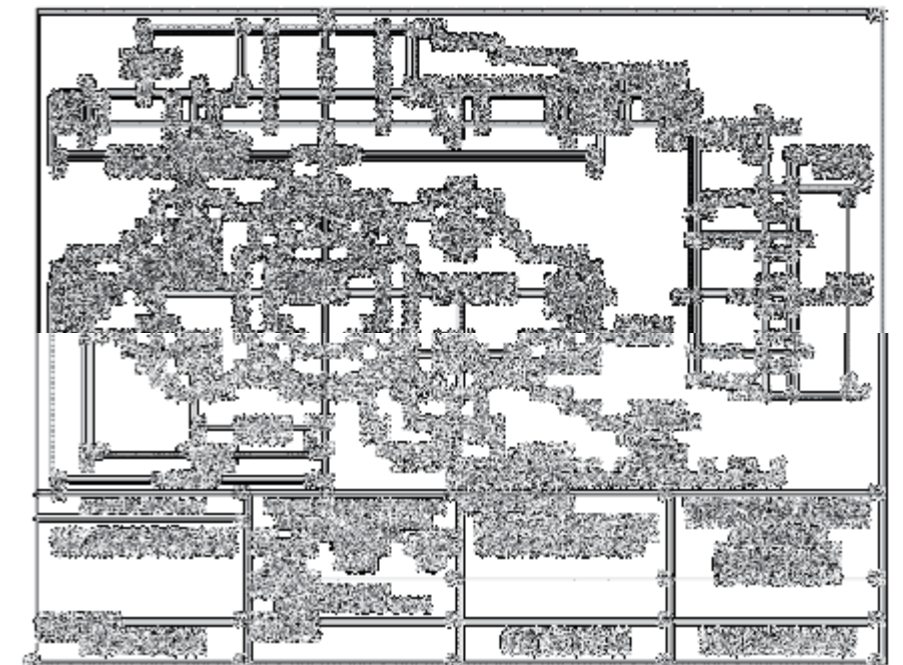
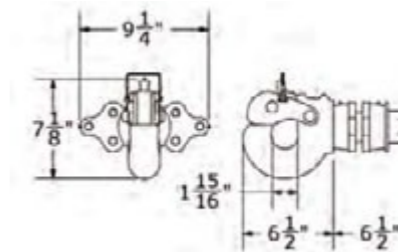

B-8 Swivel Mounted Pintle Hook

These pintle Hooks are recommended for OFF ROAD equipment and are used with a draw bar eye diameter of 2 3/8"

| Part No. | Model | Max Capacity | | W |
|----------|----------|--------------|-----|-----|
| | | G.T.W | V.L | |
| 2047104 | B-8 d=6t | 8t | 1t | 7kg |

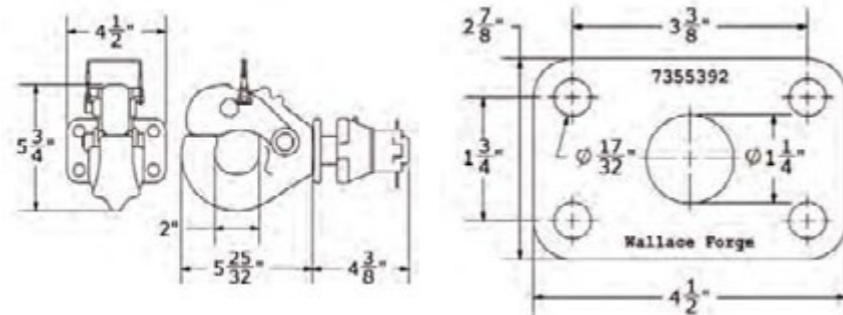

B-8 Replacement parts

| Part no. | Description |
|----------|--|
| 2088175 | Latch assembly |
| 2382151 | Snapper pin, s-hook, chain for latches |

B-50 Swivel Pintle Hook

These pintle Hooks are to be used with a drawbar with a 3" diameter eye and ring thickness 1 5/8". The holes accept 15/16" bolts

| Part No. | Model | Max Capacity | | W |
|----------|-----------|--------------|-----|------|
| | | G.T.W | V.L | |
| 2051108 | B50 D=19T | 50t | 10t | 28kg |

| 50 ton Replacement parts | |
|--------------------------|------------------------------------|
| Part no. | Description |
| 2093180 | Latch assembly |
| 2104191 | Mounting bracket |
| 2049340 | Cotter pin, s hook chain for latch |

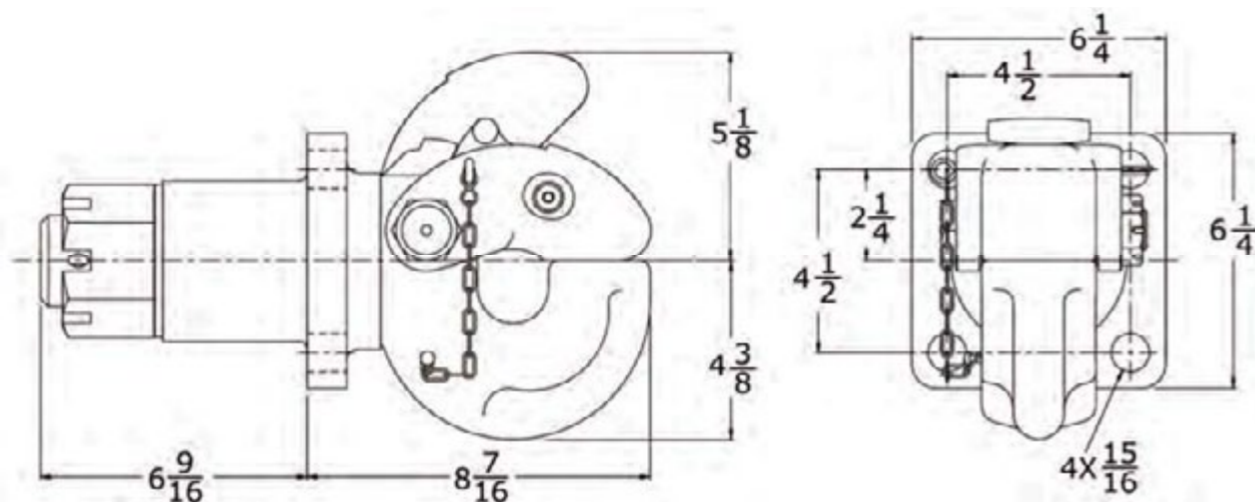

Rigid Mount Pintle Hooks

These pintle Hooks are recommended for draw bar eye dia. of 2 3/8" - 3"

| Part No. | Model | A dim | Max Capacity | | W |
|----------|-----------|--------|--------------|-----|-----|
| | | | G.T.W | V.L | |
| 2055112 | R8 d=5.8t | 17/32" | 8t | 1t | 4kg |
| 2056113 | R15 d=6t | 17/32" | 15t | 3t | 5kg |
| 2057114 | R20 d=8t | 19/32" | 20t | 3t | 6kg |

Replacement parts

| Part no. | Description |
|----------|--|
| 2105205 | Latch |
| 2382151 | Snapper pin, s hook, and chain for latches |
| 2117240 | R-5, R-7 & R-15 ton mount kits |
| 2117242 | R-20 Mounting kit |

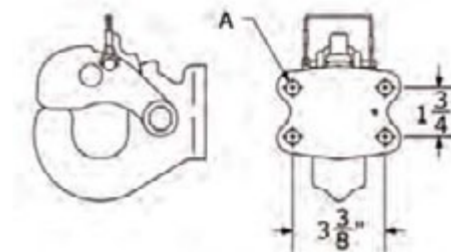

R-30 Ton Rigid Mount Pintle Hook

These Pintle Hooks are to be used with a drawbar with a 2 3/8" - 3" diameter eye.

| Part No. | Model | Max Capacity | | W |
|----------|-------|--------------|-----|------|
| | | G.T.W | V.L | |
| 2058115 | R30 | 30t | 6t | 11kg |

Replacement parts

| Part no. | Description |
|----------|----------------|
| 2058115 | Latch assembly |

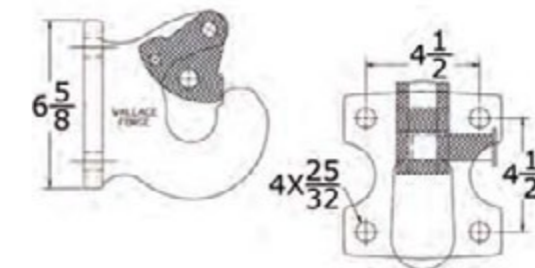

Do not weld or modify Wallace Forge Pintle Hooks. Rigid Pintle Hook capacities are reduced by 25% when used for off road purposes.

50 Ton 4 Bolt Pintle Hook

These pintle Hooks are to be used with a drawbar with a $2\frac{3}{8}$ " – 3" diameter eye and a ring thickness $1\frac{1}{4}$ " – $1\frac{5}{8}$ ". The mounting plate should be at least $\frac{7}{8}$ " thick.

| Part No. | Model | Max Capacity | | W |
|-----------------|-----------|--------------|-----|------|
| | | G.T.W | V.L | |
| 2060115/R45A4 | R45A-4 | 50t | 9t | 21kg |
| 2060115/R45A4NB | R45A-4 NB | 50t | 9t | 14kg |



| Replacement parts | |
|-------------------|------------------------------|
| Part no. | Description |
| 54454L | Latch assembly |
| 23454P | Plunger |
| 23454MB | Mount bracket |
| 23454AC | Air cylinder |
| 2391T | Thimble for air cylinder rod |

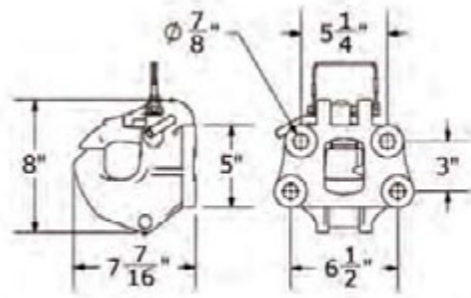

50 Ton 6 Bolt Pintle Hook

These pintle Hooks are to be used with a drawbar with a $2\frac{3}{8}$ " – 3" diameter eye and a ring thickness $1\frac{1}{4}$ " – $1\frac{5}{8}$ ". The mounting plate should be at least $\frac{7}{8}$ " thick.

| Part No. | Model | Max Capacity | | | Wt. |
|---------------|--------------|--------------|-------|-----|------|
| | | Latch | G.T.W | V.L | |
| 2060115/R45A6 | R50 NB | 27t | 50t | 9t | 17kg |
| 2060115/45 | R50 with air | 27t | 50t | 9t | 25kg |



| Replacement parts | |
|-------------------|------------------|
| Part no. | Description |
| 2091178 | Latch assembly |
| 20117P | Plunger |
| 20117MB | Mounting bracket |
| 20117AC | Air cylinder |

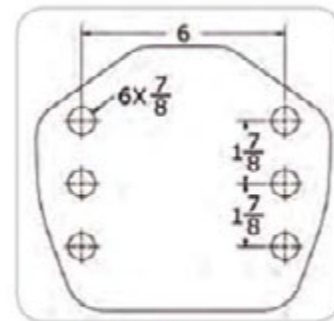
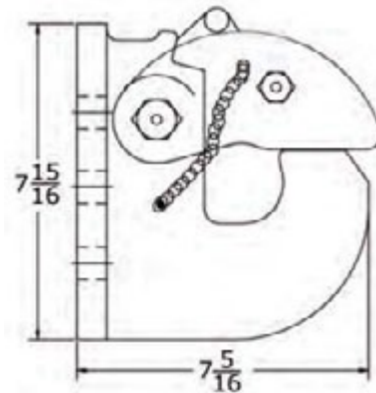

2060115/R45A6,
2060115/45 Bolt Pattern

50 Ton Offset 6 Bolt Pintle Hook

These Pintle Hooks are to be used with a drawbar with a $2\frac{3}{8}$ " – 3" diameter eye and a ring thickness $1\frac{1}{4}$ " – $1\frac{5}{8}$ ". The mounting plate should be at least $\frac{7}{8}$ " thick.

| Part No. | Model | Max Capacity | | | Wt. |
|--|--------------|--------------|-------|-----|------|
| | | Latch | G.T.W | V.L | |
| 2060115 | R50 no air | 27t | 50t | 9t | 17kg |
| 2060115R R50 suit ringfeeder pattern 160 x 100mm | | | | | |
| 2060115C | R50 with air | 27t | 50t | 9t | 25kg |



| Replacement parts | |
|-------------------|------------------|
| Part no. | Description |
| 2091178 | Latch Assembly |
| 2060P | Plunger |
| 2060MB | Mounting bracket |
| 2060AC | Air Cylinder |

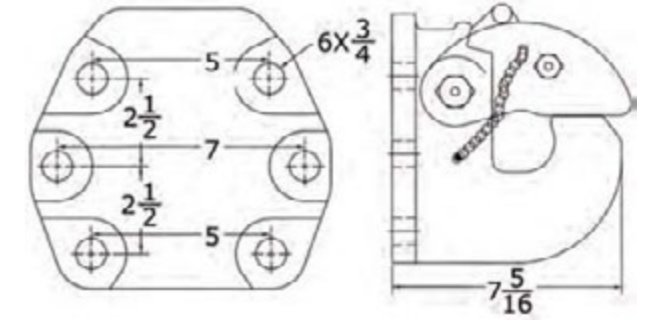

2060115R 50t Pintle Hook with 160 x 100mm. bolt pattern (Ringfeder bolt pattern)

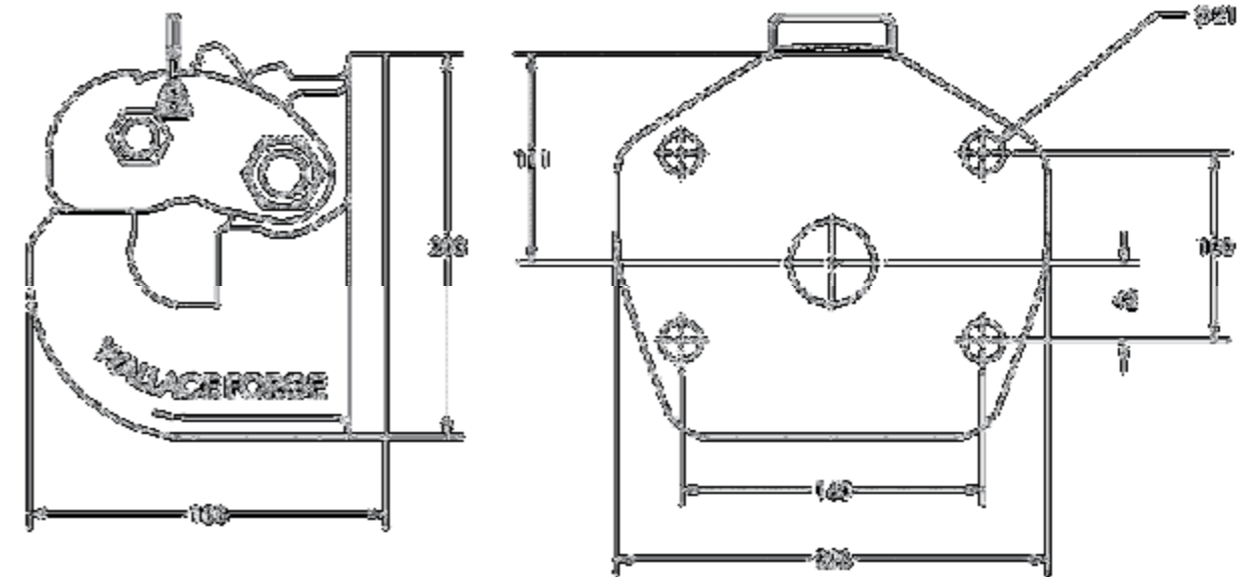

Dual Purpose Hitch

*Patented Dual Locking Assembly

*Quality forging and precision assembly offers dependable service over the life of the hitch

All balls are interchangeable for easy replacement. Hitches are individually packaged for added convenience. Dual Purpose Hitches accept 2" and 3" Wallace forge eyes.

| Part No. | Model | Dimensions | | Max Capacity | | | W |
|----------|---------|------------|-----------|--------------|--------|------|-----|
| | | A | Ball size | Hitch ball | Pintle | V.L | |
| 2078120 | DPH2516 | 17/32" | 2 5/16" | 7t | 7t | 1.5t | 7kg |
| 2331223 | DPH50mm | 17/32" | 50mm | 3.5t | 6t | 1.5t | 6kg |



Dual purpose hitch



Pintle hook in use



Ball hitch in use

| Replacement parts | |
|-------------------|------------------------|
| Part no. | Description |
| 2331223B | 50mm repl. Ball |
| 2094181 | Replacement latch |
| 2382151 | Snapper pin, chain etc |

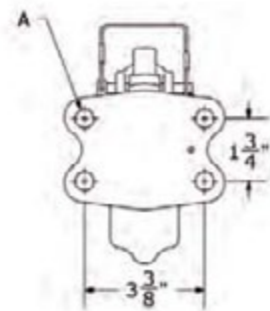

Dual Purpose Receiver

*Made for 2" receiver tubes *Interchangeable Balls

*Dual Purpose Receiver accepts 2" and 3" Wallace Forge Eyes

| Part No. | Model | Dimensions | | Max Capacity | | | W |
|----------|---------|------------|-----------|--------------|--------|------|-----|
| | | A | Ball size | Hitch ball | Pintle | V.L | |
| 2079121A | DPR50mm | 4 3/16" | 50mm | 3.5t | 6t | 1.5t | 8kg |

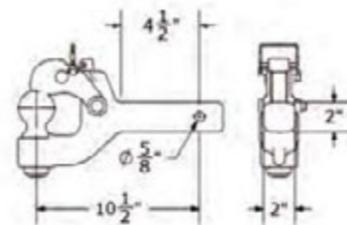

Heavy Duty Rigid Mount Magnum Hitch

These hitches have the same mounting hole location as DPH's, mounting holes accept 9/16" bolts. Accepts 2" and 3" Wallace Forge eyes.

| Part No. | Model | Max Capacity | | W |
|----------|--------------------|--------------|-----|-----|
| | | G.T.W | V.L | |
| 2101188 | Magnum (ball 50mm) | 10t | 2t | 8kg |



| Replacement parts | |
|-------------------|------------------------|
| Part no. | Description |
| 2101188B | 50mm repl. Ball |
| 2098189 | Replacement latch |
| 2382151 | Snapper pin, chain etc |

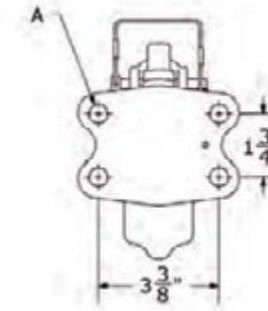

Gooseneck Coupler Heads

| Part no. | Description | Max gross trailer wt. | W |
|----------|--------------------------------|-----------------------|-------|
| 1025166 | For 2 5/8" ball, lock pin inc. | 12t | 4kg |
| HPL12312 | 1/2" x 3 1/2" hitch pin only | - | 0.7kg |
| 1025165 | For 3" ball, lock pin inc. | 12t | 5kg |
| HPL34414 | 3/4" x 4 1/4" hitch pin only | - | 0.7kg |

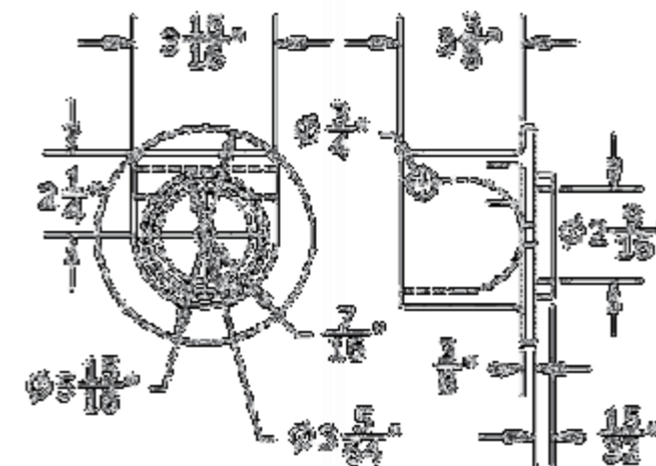

Hideaway Tow Ball

Wallace Forges patented design enables the chrome ball to stay clean, and free of dirt when the ball is folded down. When the ball is in the up position it locks up with a self-locking pin.

- *Easily greased while hitch ball is in the upright position
- *Manufactured with a 3/8" thick plate, thickest on the market by 1/8"
- *forged chain attachments fit flush against hideaway
- *forged door hinge fits securely against hitch ball to eliminate slop and provide maximum wear resistance
- *Secondary locking pin ensures that forged chrome hitch ball locks into place
- * brackets and sub brackets sold separately

| Part No. | Description | Max Capacity | | W |
|----------|---|--------------|------|------|
| | | G.T.W | V.L | |
| 2025161 | 2 5/16" folding hitch ball with safety attachment | 13t | 2.5t | 19kg |
| 2026666 | Adjustable undercarriage, will fit most pick-up and light duty trucks | - | - | 20kg |



P/N: 2025161



P/N: 2026666

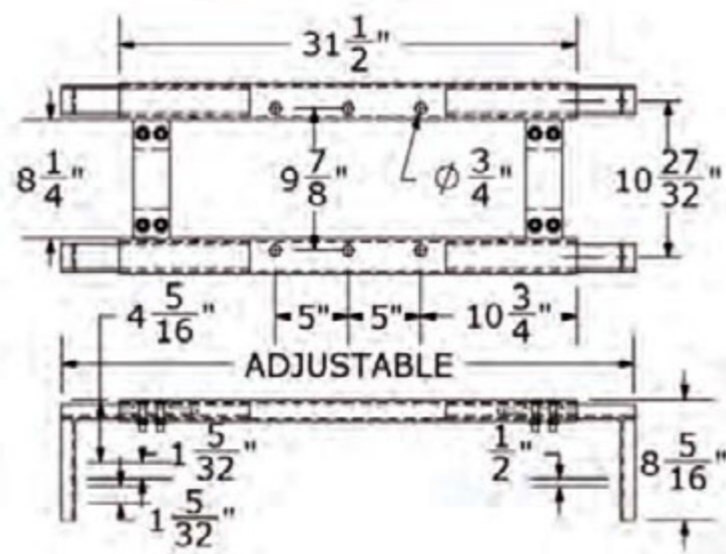

Trailer Nose Plates

Weldable

Plates allow for 3 different mounting positions. Pre Drilled nose plates must be reinforced to meet capacity.

| Part No. | Description | Hole size A | Thickness B | W |
|----------|--|-------------|-------------|------|
| TNP16100 | 1" nose plate – use for R-50-B, R-51-A | 25/32" | 1" | 15kg |

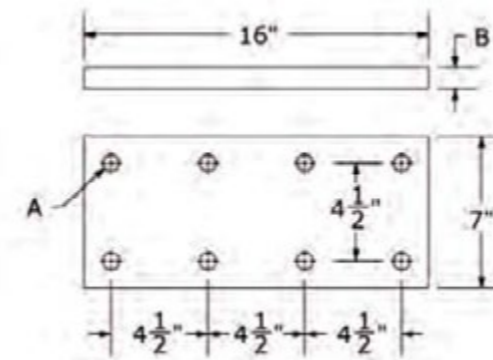

Bolt on Tow Rings

| Part no. | Model | Dimensions (mm) | | | | | | Max Capacity | | W |
|----------|-------|-----------------|-------|-----|----|----|----|--------------|------|------|
| | | A | B | C | D | E | F | G.T.W | V.L. | |
| 2067135 | R51A | 76 | 152.5 | 114 | 20 | 67 | 57 | 45t | 9t | 10kg |

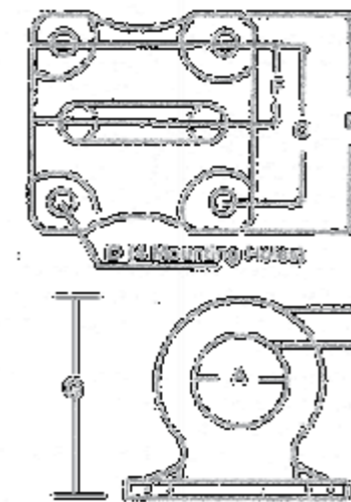

Warning!! Do not use Pintle Hooks that restrict the movement or rotation of the pintle ring. This includes, but is not excluded to, "fish mouth" style tow hooks designed strictly for ON ROAD towing.

Swivel Tow Rings

| Part no. | Model | Dimensions (mm) | | | | Max Capacity | | W |
|----------|------------------|-----------------|----|-------|------|--------------|------|-------|
| | | A | B | C | D | G.T.W | V.L. | |
| 2062128 | 0-51-B | 76 | 27 | 101.5 | 50.8 | 25t | 3t | 7.5kg |
| 2062128B | Block for 0-51-B | | | | | | | |
| 2063126 | 51337 | 76 | 27 | 209.5 | 50.8 | 25t | 4.5t | 11kg |
| 2063126B | Block for 51337 | | | | | | | |

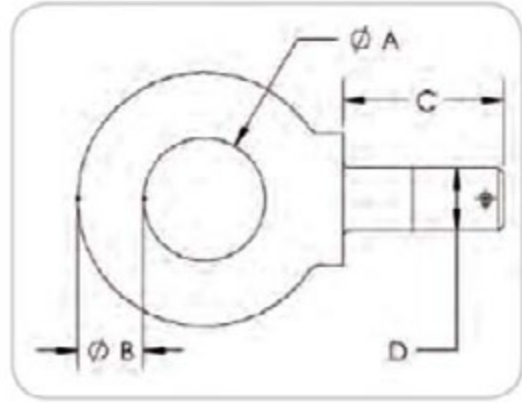

2062128

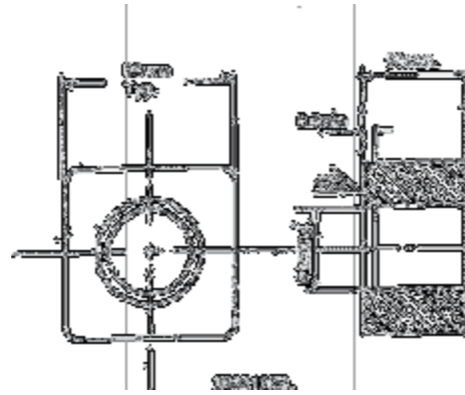

2063126

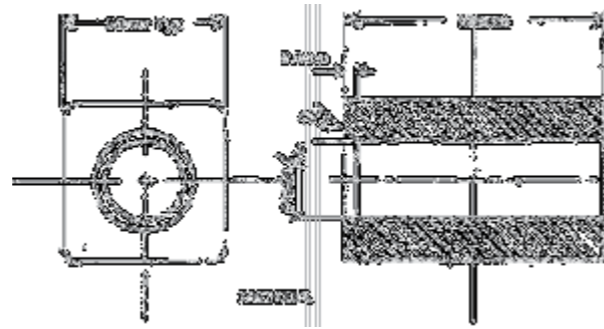

Bolt on Drawbars

Do not weld or modify

| Part no. | Model | Dimensions (mm) | | | | | | Standard capacity | | Hinged tongue cap. | | W |
|----------|-------|-----------------|-----|------|------|------|------|-------------------|------|--------------------|-------|------|
| | | A | B | C | D | E | F | G.T.W | V.L. | G.T.W | V.L. | |
| 1111238 | 052-D | 76.2 | 438 | 76.2 | 41.3 | 41.3 | 50.8 | 10t | 2t | 50t | 200kg | 13kg |
| 2068133 | 0-51E | 76.2 | 381 | 76.2 | 63.5 | 41.3 | 38.1 | 15t | 3t | 50t | 200kg | 14kg |

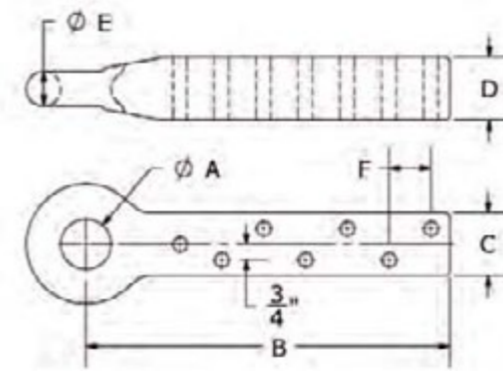

Fish Tail Tow Rings

| Part no. | Model | Dimensions (mm) | | | | | Max Capacity | | W |
|----------|--------|-----------------|-----|-------|------|------|--------------|------|-------|
| | | A | B | C | D | E | G.T.W | V.L. | |
| 2069120 | 0-51LT | 76 | 305 | 152.5 | 98.5 | 28.5 | 10t | 2t | 7.5kg |

Dimensions B and C should only be welded for mounting.

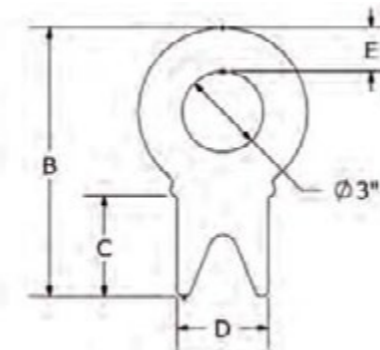

Hitch Balls

Do not weld hitch balls. Nut not included

| Part no. | Model | Dimensions (mm) | | | | Finish | Max capacity GTW | W |
|----------|--------|-----------------|------|------|------|---------|------------------|-------|
| | | A | B | C | D | | | |
| 2326218 | CBH4A | 58.5 | 32 | 54 | 79.5 | Chrome | 7 500 | 4.5kg |
| 2325200 | CBH9A | 58.5 | 25.5 | 57 | 67 | Chrome | 10 000 | 3kg |
| 2325201 | CBH10A | 58.5 | 32 | 76 | 87 | Machine | 30 000 | 5kg |
| 2325222 | CB3A | 58.5 | 32 | 67 | 89 | Machine | 30 000 | 5kg |
| 2083163 | BH5A | 76 | 51 | 82.5 | 114 | Machine | 40 000 | 7kg |

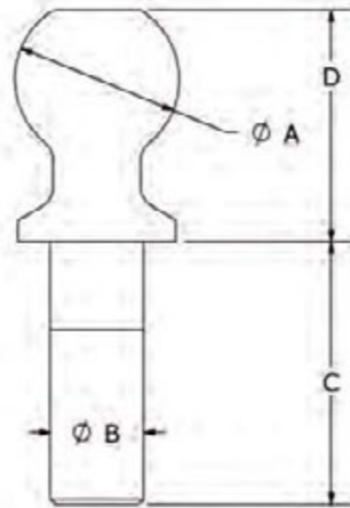

High Rise & Hex Collar Hitch Balls

Do not weld hitch balls. Nut not included

| Part no. | Dimensions (mm) | | | | | Finish | Max capacity GTW | W |
|----------|-----------------|----|------|-----|------|--------|------------------|-----|
| | A | B | C | D | E | | | |
| 2325221 | 58.5 | 35 | 82.5 | 107 | 25.5 | Zinc | 30 000 | 4kg |
| 2325220 | 58.5 | 38 | 76.5 | 134 | 51 | Zinc | 30 000 | 5kg |

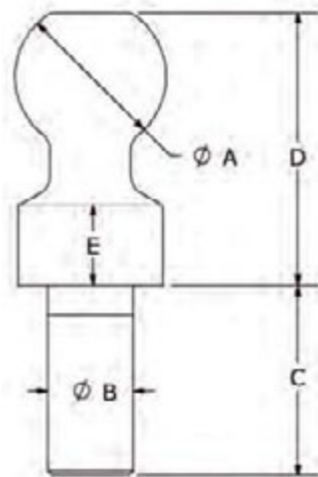

Forged Collar Receiver Tubes

*heavy duty forged collar *Accepts 2" square hitch bar

*Receiver tubes are drilled for a 5/8" hitch pin

| Part no. | Model | Tube length | Max cap. GTW | W |
|----------|-------|-------------|--------------|---------|
| 2359128 | RT6 | 6" | 10 000 | 2 kg |
| 2360129 | RT8 | 8" | 10 000 | 2.5 kg |
| 2361130 | RT10 | 10" | 10 000 | 3 kg |
| 2361131 | RT12 | 12" | 10 000 | 3.5 kg |
| 2361132 | RT18 | 18" | 10 000 | 4.5 kg |
| 2361133 | RT24 | 24" | 10 000 | 7.5 kg |
| 2361134 | RT36 | 36" | 10 000 | 11 kg |
| 2361135 | RT48 | 48" | 10 000 | 14.5 kg |



Bent Hitch Pin Assembly

*white zinc plated to resist corrosion

| Part no. | Model | W |
|----------|---------------------------------|-------|
| 2319210 | 1/2" hitch pin and spring clip | 0.5kg |
| 2319211 | 3/8" hitch pin and spring clip | 0.5kg |
| 2160000 | 9/64" x 3" spring clip only | 0.1kg |
| 2110000 | 3/32" x 1 5/8" spring clip only | 0.1kg |



Step Bumper Hitch Box

*Black finish with grade 5 bolts

*class 3 – 5,000 lbs GTW

*500lbs tongue weight

*Accepts 5/8" hitch pin

Do Not Exceed Bumper Rating

| Part no. | Max capacity GTW | W |
|----------|------------------|-----|
| 2362131 | 5 000 | 5kg |



Receiver Tube Extenders

A hitches max capacity is reduced by 33% when a hitch extender is used.

| Part no. | Model | Dimensions | | W |
|----------|--------------------|------------|-----|------|
| | | A | B | |
| 2200007 | 7" Hitch Extender | 12.75" | 7" | 6kg |
| 2200014 | 14" Hitch Extender | 19.75" | 14" | 10kg |
| 2200018 | 18" Hitch Extender | 22.75" | 18" | 11kg |

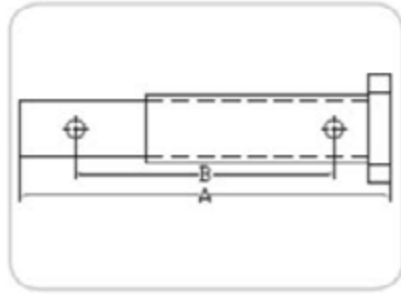

Pintle Hook Adaptors

| Part no. | Model | # of holes | Dimensions | | | Max cap. GTW |
|----------|--------|------------|------------|-------|----|--------------|
| | | | A | B | C | |
| 2202172 | RE6504 | 4 | 9" | 4" | 7" | 12 000 |
| 2203173 | RE8504 | 4 | 12" | 4" | 9" | 12 000 |
| 2200170 | RE6500 | 8 | 9" | 7.5" | 7" | 12 000 |
| 2201171 | RE8500 | 8 | 12" | 7.5" | 9" | 12 000 |
| 2354246 | RE6511 | 12 | 9" | 11" | 7" | 12 000 |
| 2355247 | RE8511 | 12 | 12" | 11" | 9" | 12 000 |
| 2352244 | RE6512 | 14 | 9" | 12.5" | 7" | 10 000 |
| 2353245 | RE8512 | 14 | 12" | 12" | 9" | 10 000 |
| 2353246* | RE2500 | 8 | 12" | 7.5" | 7" | 12 000 |

RE2500 is designed for 2.5" receiver tubes

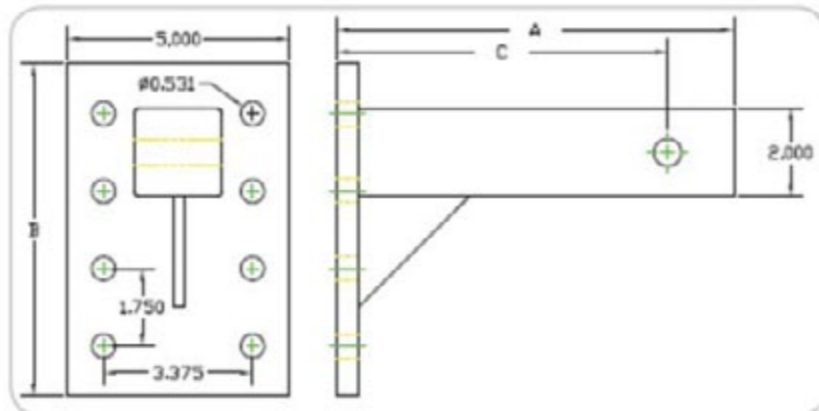

V.Orlandi E520 Pacific

AUTOMATIC COUPLING FOR DRAW BAR EYES Ø50mm 94/20/CE

This coupling is designed specifically for the Australian market. The mechanism box is completely sealed from dust and dirt. The bell mouth can be replaced and pin lasts longer due to the extended heat treatment. It has a new manual safety device (RG00589) which can be easily retro fitted to the E520 Pacific. The coupling can be disengaged in any position and the handle is situated in a safe and convenient location behind the bell mouth

Features include:

Stronger – D-value 280 kN (Road Train rated)

Lighter - Lightest 50mm in the market

Silent – new bell-mouth spring = no more bell mouth shaking

Stronger – Strongest 50mm in the market.



| P/N | HOLE PATTERN MM | D – VALUE kN | Dc – VALUE kN | S – LOAD kg | V – VALUE kN | W (Kg) | CRN |
|---------|--------------------|-----------------|------------------|----------------|-----------------|-----------|-------|
| GE520F0 | 160 x 100 | 280 | 140 | 1000 | 90 | 49 | 37471 |

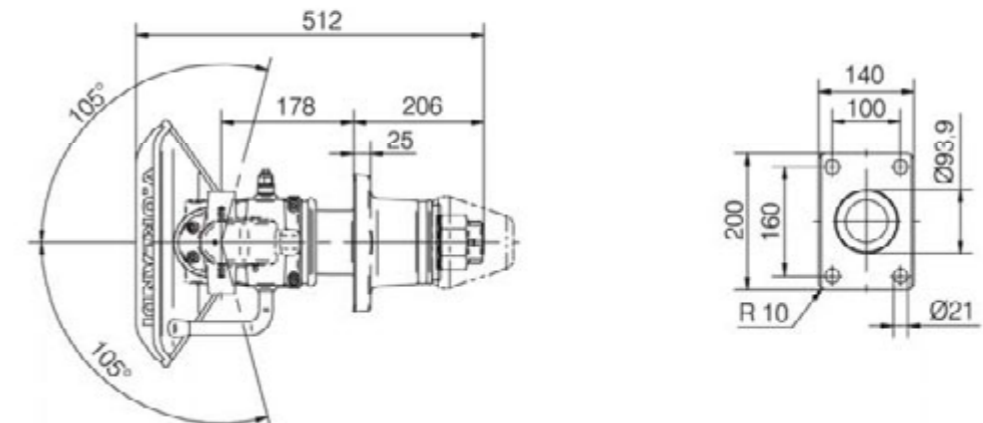
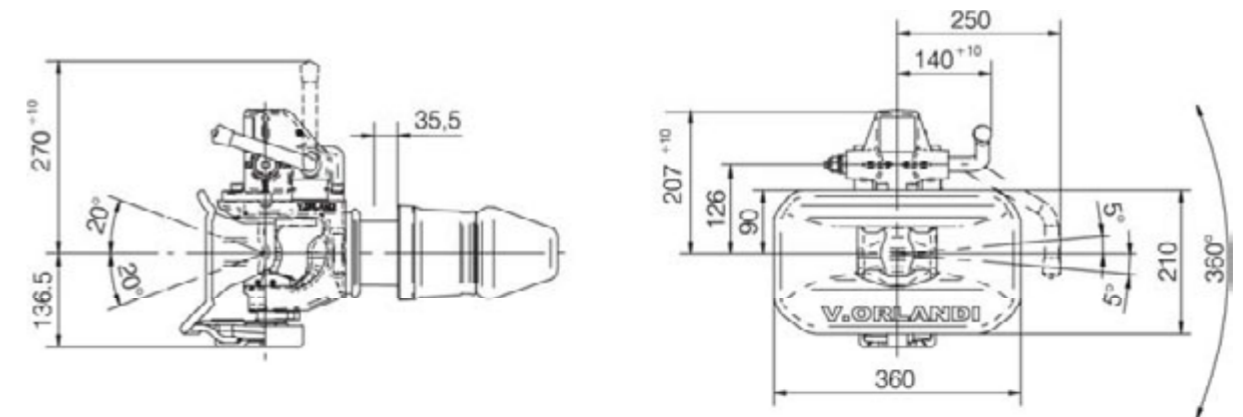



Ricambi - Spare parts E 520 PACIFIC

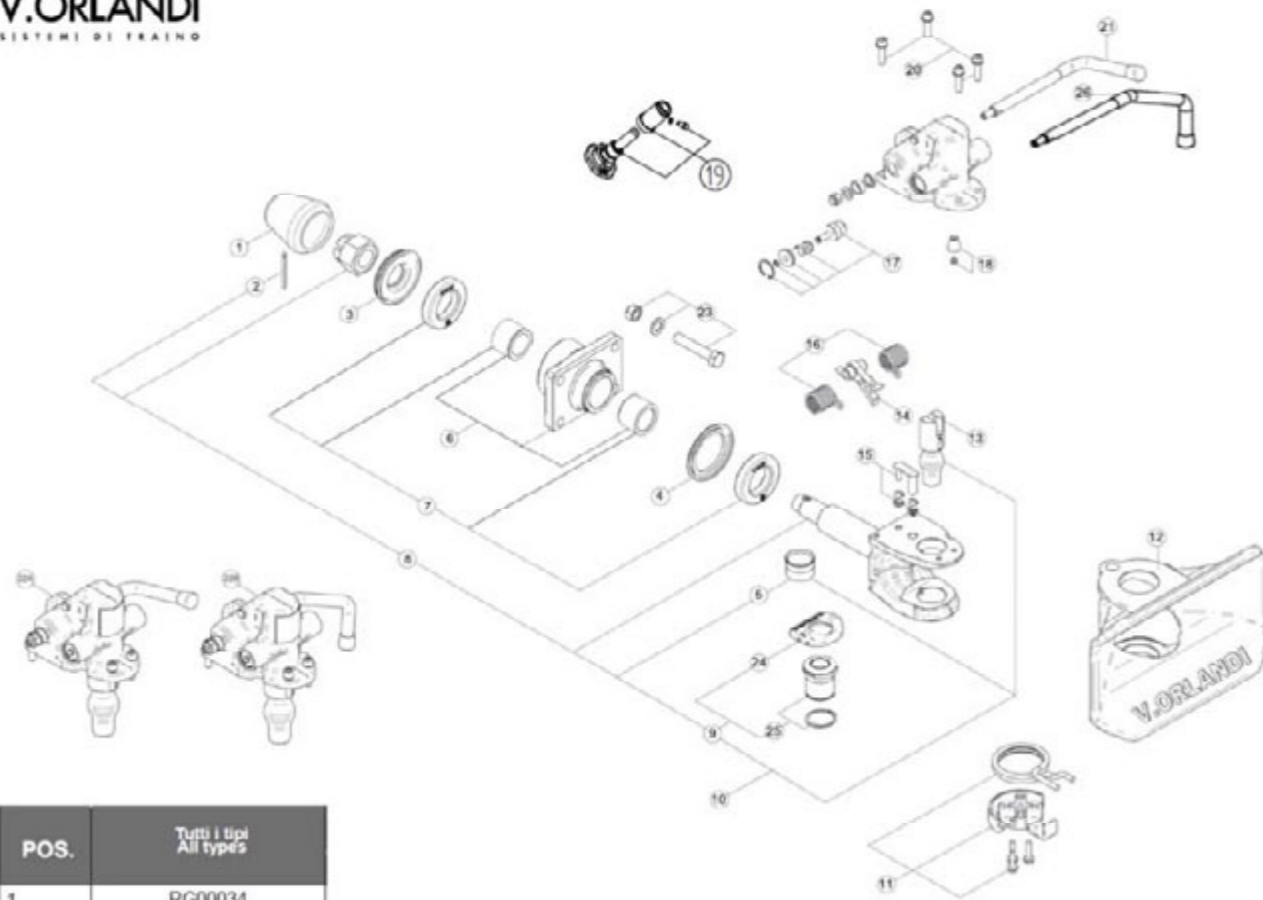

| POS. | Tutti i tipi All types |
|------|---------------------------|
| 1 | RG00034 |
| 2 | RG00064 |
| 3 | RG00421 |
| 4 | RG00422 |
| 5 | RG00088 |
| 6 | RG00423 |
| 7 | RG00425 |
| 8 | RG00426 |
| 9M | RG00427 |
| 9P | RG00428 |
| 10 | RG00429 |
| 11 | RG00529 |
| 12 | RG00193 |
| 13 | RG00430 |
| 14 | RG00188 |
| 15 | RG00179 |
| 16 | RG00178 |
| 17 | RG00181 |
| 18 | RG00091 |
| 19 | RG00589 |
| 20 | RG00185 |
| 21 | RG00186 |
| 22A | RG00431 |
| 22B | RG00432 |
| 23 | RG00132 |
| 24M | RG00269 |
| 24P | RG00270 |
| 25 | RG00433 |
| 26 | RG00187 |

M: Metallo - Metal P: Plastica - Plastic

ATTENZIONE!
Pos. 23 NON è inclusa nella fornitura
del gancio standard.

ATTENZIONE!
Pos. 23 is NOT included into the standard
order code.

Body Hardware

Rear Pivot kit 1" - P/N: BDHKIT009

**Contents**

- 25mm x 1200mm pivot bar
- Side plates
- Bushes
- Collars

Also Included:
Grease nipples, nuts, bolts
and washers

Rear Pivot kit 1.5" - P/N: BDHKIT008

**Contents**





- 38mm x 1000mm pivot bar
- Side plates
- Pivot shoes
- Bushes
- Collars

Also Included:
Grease nipples, nuts, bolts
and washers

Body Hardware

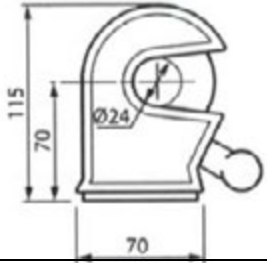
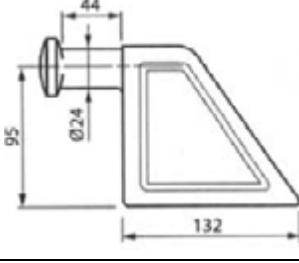

Tail gate kit side swing 24mm Standard

Kit P/N: BDHKIT024STD

| Side swing top hinge | bottom hinge P/N: 17008321 | 24mm Latch P/N: BDH20.011 | 24mm Pivot P/N: BDH20.012 |
|---|---|--|---|
|  |  |  |  |
| bar \varnothing 27mm P/N: 050101025 Bush x 2 P/N: 050101026 Collar x4 P/N: 050101027 | Pin \varnothing 25 x 118mm Including split pin |  |  |

Tail gate kit side swing 24mm compact



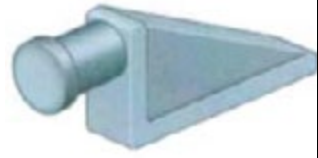
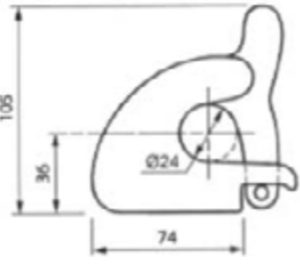
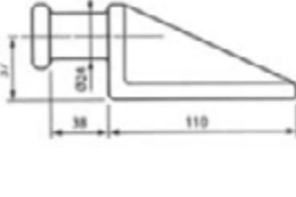

Kit P/N: BDHKIT024COM

| Side swing top hinge | bottom hinge P/N: 17008321 | 24mm latch compact P/N: 17008338 | 24mm pivot compact P/N: 17008321 |
|---|---|--|---|
|  |  |  |  |
| bar \varnothing 27mm P/N: 050101025 Bush x 2 P/N: 050101026 Collar x4 P/N: 050101027 | Pin \varnothing 25 x 118mm Including split pin |  |  |

Body Hardware



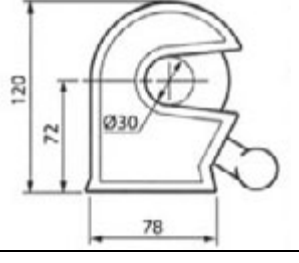
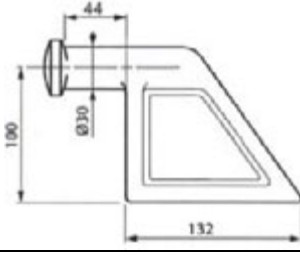

Tail gate kit side swing 30mm Standard

Kit P/N: BDHKIT030STD



| Side swing top hinge | bottom hinge P/N: 17008321 | 30mm Latch P/N: BDH20.013 | 30mm Pivot P/N: BDH20.014 |
|---|---|---|---|
|  |  |  |  |
| bar \varnothing 27mm P/N: 050101025 Bush x 2 P/N: 050101026 Collar x4 P/N: 050101027 | Pin \varnothing 25 x 118mm Including split pin |  |  |

Tail gate kit side swing 40mm Standard

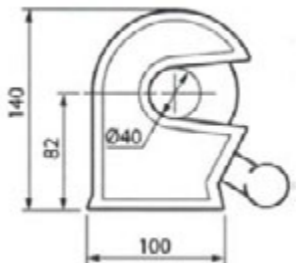
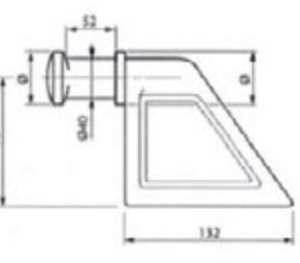
Kit P/N: BDHKIT040STD

| Side swing top hinge | bottom hinge P/N: 17008322 | 40mm Latch P/N: 17008332 | 40mm Pivot P/N: 17008322 |
|---|---|---|---|
|  |  |  |  |
| bar \varnothing 35mm (offset 70mm) P/N: 050101018 Bush x 2 P/N: 050101019 Collar x4 P/N: 050101020 | Pin \varnothing 30 x 140mm Including split pin |  |  |

Body Hardware

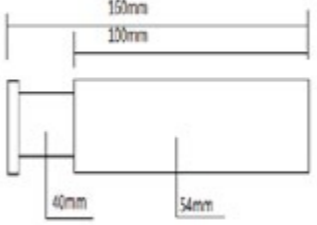
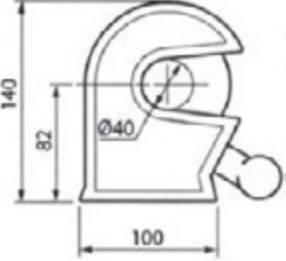
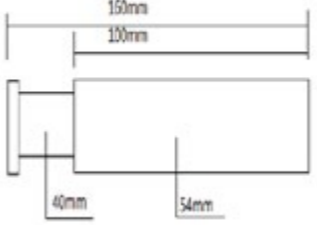
| | | | |
|--|---|---|---|
| Tail gate kit side swing 40mm machined Pin Kit P/N: BDHKIT040MAC | | | |
| Side swing top hinge | bottom hinge P/N: 17008322 | 40mm Latch P/N: 17008332 | 40mm Pivot P/N: 17008323 |
|  |  |  |  |
| bar Ø35mm (offset 70mm) P/N: 050101018 Bush x 2 P/N: 050101019 Collar x4 P/N: 050101020 | Pin Ø30 x 140mm Inc split pin |  |  |

Hyva Mud Flaps

| Part no. | Description | Size |
|----------|-----------------|---------------|
| MF2417 | Small mud flap | 24" W x 17" L |
| MF2424 | Medium mud flap | 24" W x 24" L |
| MF2430 | Large mud flap | 24" W x 30" L |



Landing Legs for Drawbars

| Part no. | Drop leg section | Load capacity | Stroke |
|----------|------------------|---------------|--------|
| 158151TP | Na | 900kg | 400mm |
| 158452TP | Na | 900kg | 381mm |
| 190510 | 340mm | 3175kg | 381mm |
| 190510TW | 340mm | 3175kg | 381mm |

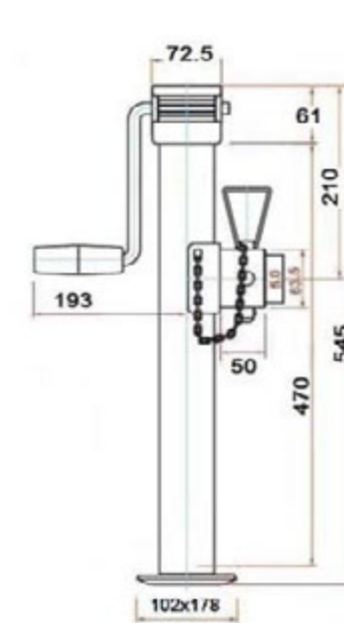

158151TP

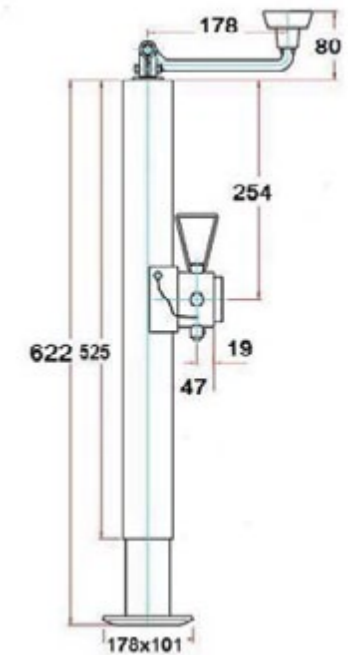

158452TP

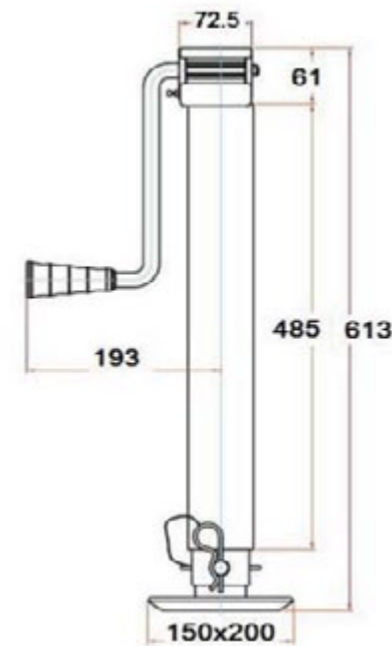

190754ND

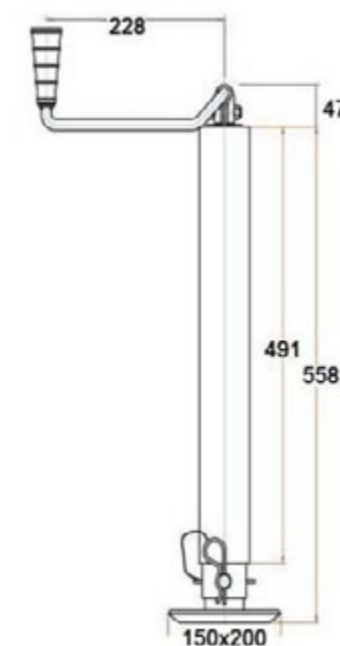

190510TW

8 TONNE SKIP LOADER NG2008TA

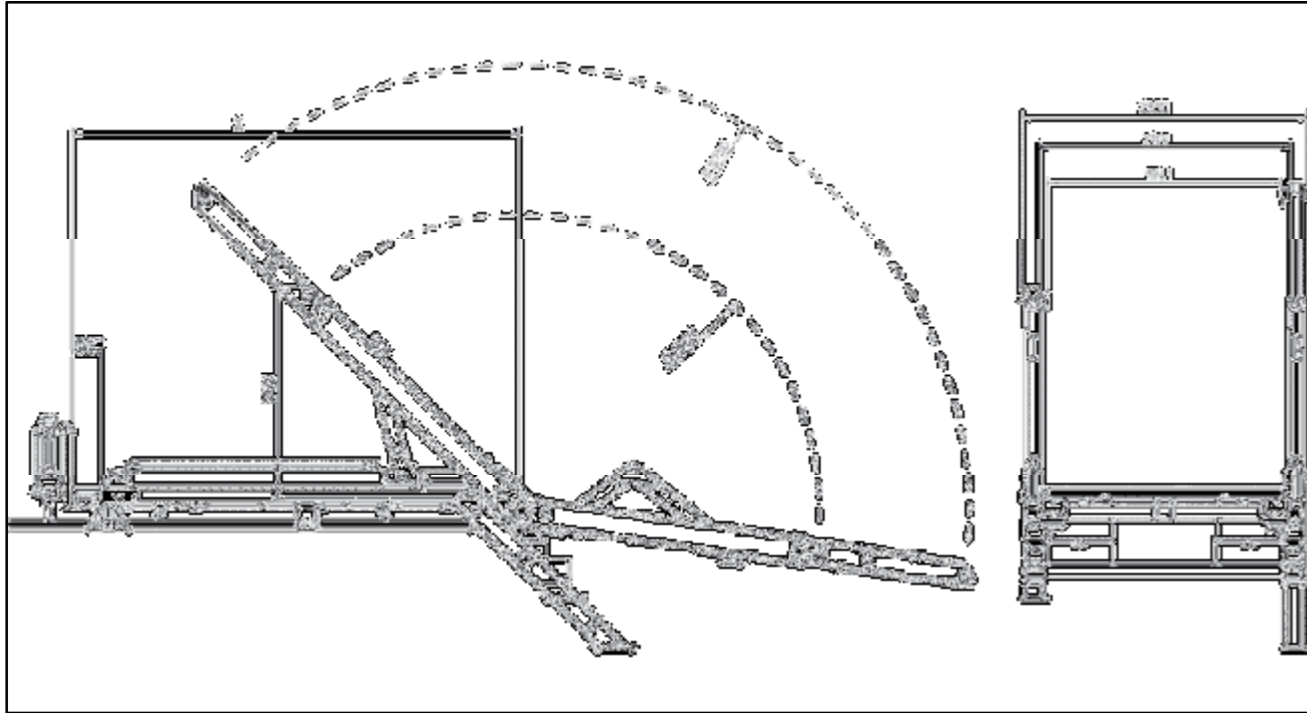

| TYPE: | NG2008TA | NG2008TA + 850 EXT | NG2008TA + 1350 EXT | NG2008TA + 1680 EXT |
|--|----------|--------------------------|---------------------------|---------------------------|
| X (mm) Bed Length | 3.470 | 4.320 | 4.820 | 5.150 |
| External lever controls passenger side | Standard | Standard | Standard | Standard |
| Lifting capacity (Kg) | | | | |
| Arm length 2500 mm | 8.000 | 8.000 | 8.000 | 8.000 |
| Arm length 3750 mm ³ | 4.500 | 4.500 | 4.500 | 4.500 |
| Lifting strength 800mm sub floor (Kg) | | | | |
| Arm length 2500 mm | 5.600 | 5.600 | 5.600 | 5.600 |
| Arm length 3750 mm ³ | 2.000 | 2.000 | 2.000 | 2.000 |
| Approx. Useable loading capacity (depending on chassis height) (Kg) | ±8.000 | ±8.000 | ±8.000 | ±8.000 |
| Standard weight (Kg) ¹ | ±2.300 | ±2.450 | ±2.470 | ±2.500 |
| Pick up -time ² (s) | 44 | 44 | 44 | 44 |
| Unloading-time ² (s) | 36 | 36 | 36 | 36 |
| Jack legs out/in ² (s) | 4 | 4 | 4 | 4 |
| Telescopic arm out/in ² (s) | 9 | 9 | 9 | 9 |
| Fast off load empty container ² (s) (Optional extra) | 13 | 13 | 13 | 13 |

¹ Rough estimation based on a standard system, incl. sub frame, excl options.

² Rough estimation based on: PTO type C, pump 60 l/min., motor 1200 rpm, PTO transmission i = 1.0.

³ Based on lifting arms under an angle of 15°
Pressure and Flow of 60 litres a minute at 195 bar

14 TONNE SKIP LOADER NG2014TA XL

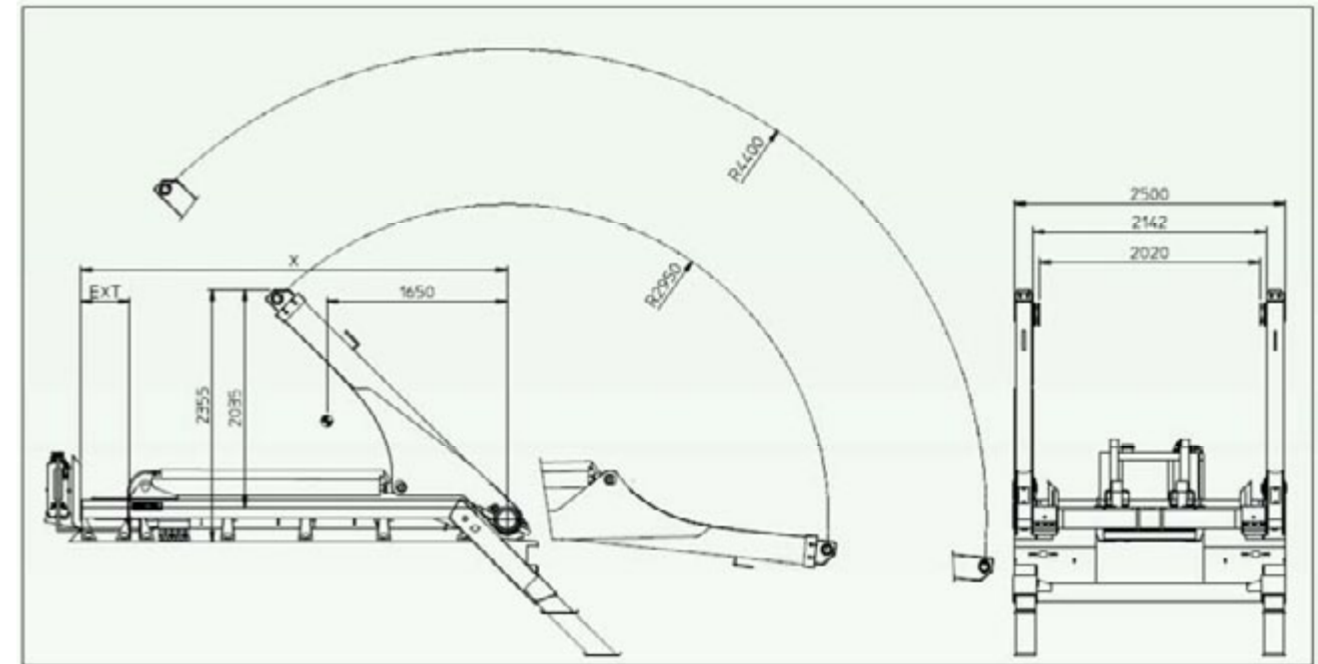

| Technical details Hyva Lift NG2014TA XL | Hyvalift NG2014TA XL + 1350 Ext | Hyvalift NG2014TA XL + 850 Ext |
|--|---------------------------------------|--------------------------------------|
| Bed Length Australian Spec (x) mm | 4820mm | 4320mm |
| Lifting capacity (Kg) | | |
| Arm length 2950 mm | 14,000 | 14,000 |
| Arm length 4400 mm ³ | 9,300 | 9,300 |
| Lifting strength 800mm sub floor (Kg) | | |
| Arm length 2950 mm | 9,500 | 9,500 |
| Arm length 4550 mm ³ | 6,300 | 6,300 |
| Approx. Useable loading capacity (depending on chassis height) (Kg) | ±14.000 | ±14.000 |
| Standard weight (Kg) ¹ | ±3.070 | ±3.040 |
| Pick up -time ² (s) | 33 | 33 |
| Unloading-time ² (s) | 27 | 27 |
| Jack legs out/in ² (s) | 8 | 8 |
| Telescopic arm out/in ² (s) | 11 | 11 |
| Fast off load empty container ² (s) | 16 | 16 |

¹ Rough estimation based on a standard system, incl. sub frame, excl options.

² Rough estimation based on: PTO type C, pump 80 l/min., motor 1200 rpm, PTO transmission i = 1.0.

³ Based on lifting arms under an angle of 15°
Pressure and Flow of 80 litres a minute at 245 bar

18 TONNE SKIP LOADER NG2018TA XL

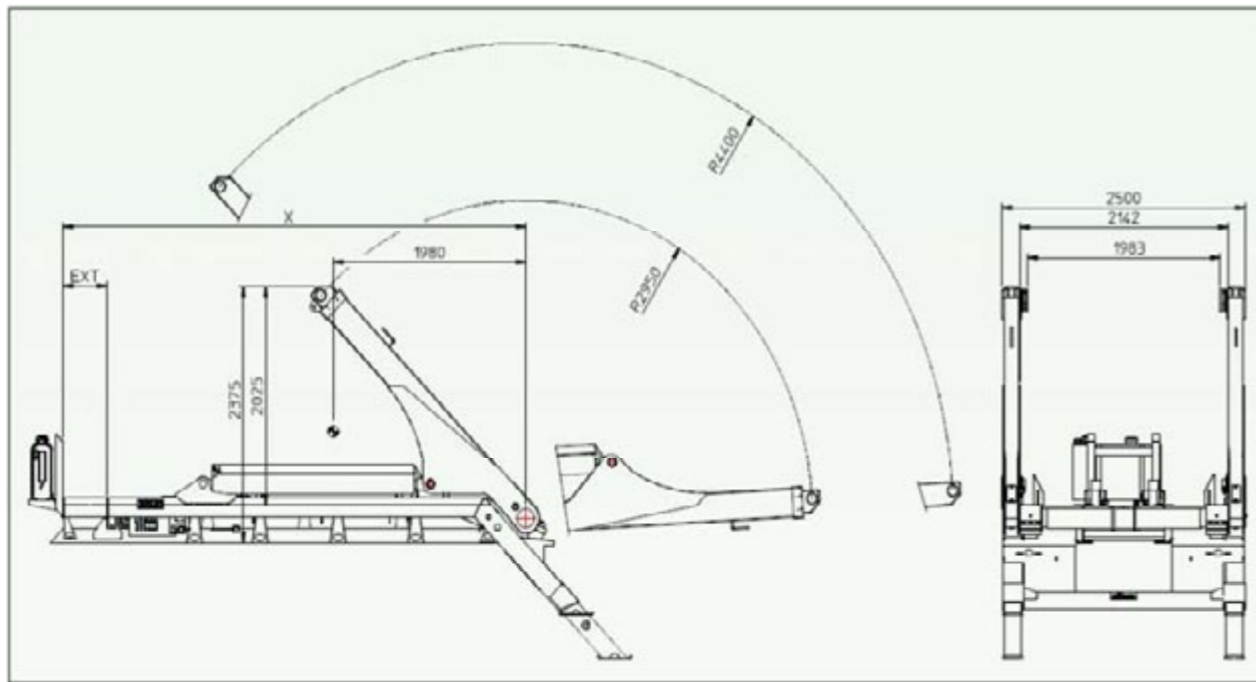

| Technical details | Hyvalift NG2018TA XL + 450 Ext | Hyvalift NG2018TA XL + 850 Ext |
|---|--------------------------------------|--------------------------------------|
| Bed Length Australian Spec (x) mm | 4770mm | 5170mm |
| Lifting capacity (Kg) | | |
| Arm length 2950 mm | 18,000 | 18,000 |
| Arm length 44000 mm ³ | 12,000 | 12,000 |
| Lifting strength 800mm sub floor (Kg) | | |
| Arm length 2950 mm | 12,500 | 12,500 |
| Arm length 4400 mm ³ | 8,250 | 8,250 |
| Approx. Useable loading capacity (depending on chassis height) (Kg) | ±18.000 | ±18.000 |
| Standard weight (Kg) ¹ | ±3.650 | ±3.685 |
| Pick up -time ² (s) | 40 | 40 |
| Unloading-time ² (s) | 32 | 32 |
| Jack legs out/in ² (s) | 8 | 8 |
| Telescopic arm out/in ² (s) | 11 | 11 |
| Fast off load empty container ² (s) | 16 | 16 |

¹ Rough estimation based on a standard system, incl. sub frame, excl options.

² Rough estimation based on: PTO type C, pump 80 l/min., motor 1200 rpm, PTO transmission i = 1.0.

³ Based on lifting arms under an angle of 15°
Pressure and Flow of 80 litres a minute at 265 bar

3 TONNE 'CITY' HOOK LOADER – K TYPE

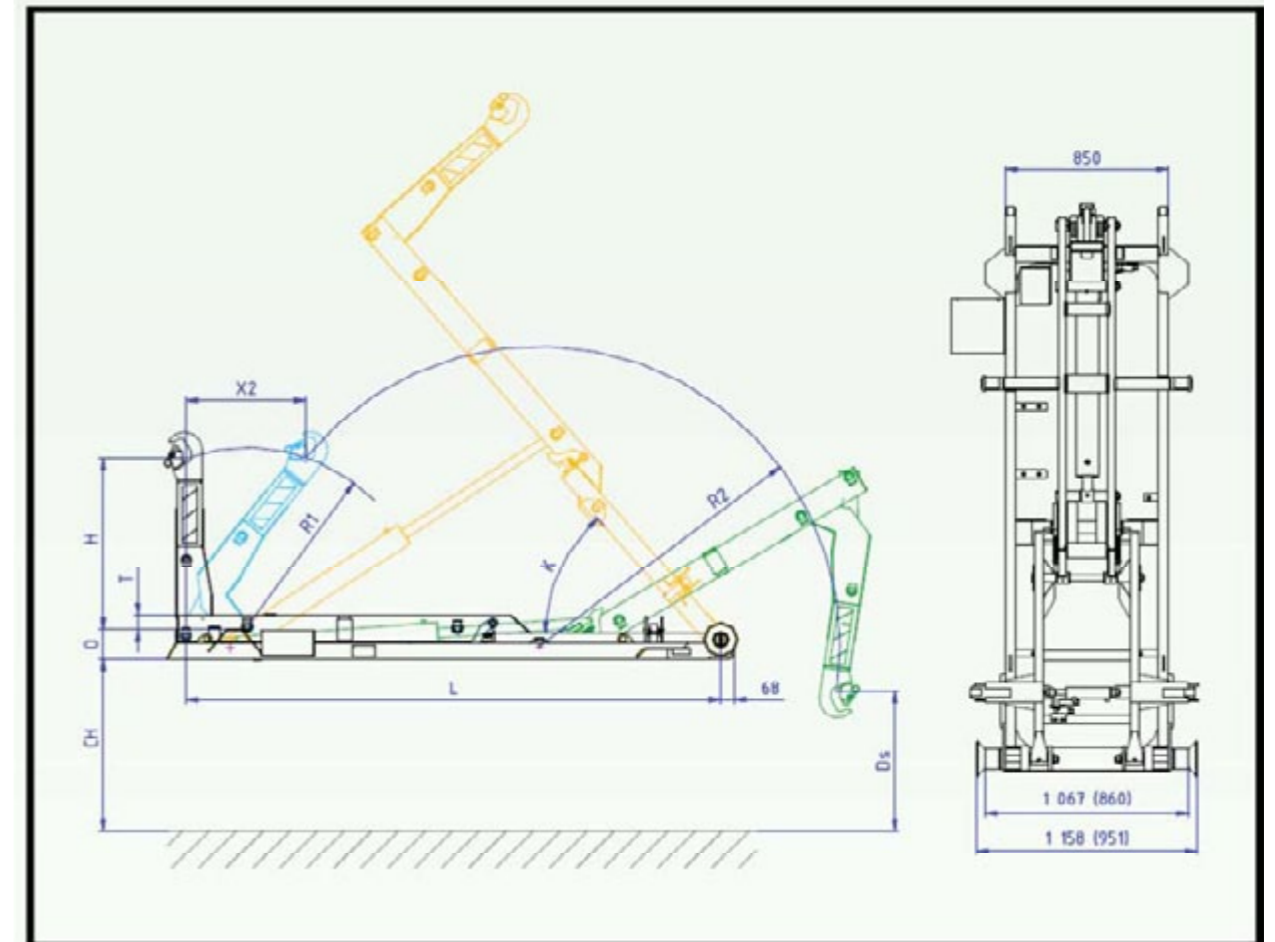

Specifications :

| TYPE | 03-2S-K-DIN |
|---|---------------|
| Lifting and tipping capacity (t) | 3 |
| Maximal working pressure (MPa) | 25 |
| H (mm) | 900 |
| X2 (mm) | 627 |
| O (mm) | 153 |
| L (mm) | 2 800 |
| K (°) | 49 |
| T (mm) | 75 |
| R1 (mm) | 939 |
| R2 (mm) | 1 575 |
| Ds (mm) | 730 |
| System weight incl. operating fluids (kg) | 425 |
| MIN./MAX. length of the container (mm) | 3 200 / 3 400 |

ATTENTION ! Height of undercarriage reduces the capacity of the hook loader.

H = Hook height (mm)

CH = Chassis height (mm)

Standard supplied oil tank : 10 lt.

Hydraulic pump – recommended values : 17 (20) lt./min. / 28 MPa

System standard delivered with roller width 1067/1158. As option roller width 860/951 can be delivered.

6 TONNE 'CITY' HOOK LOADER – S TYPE

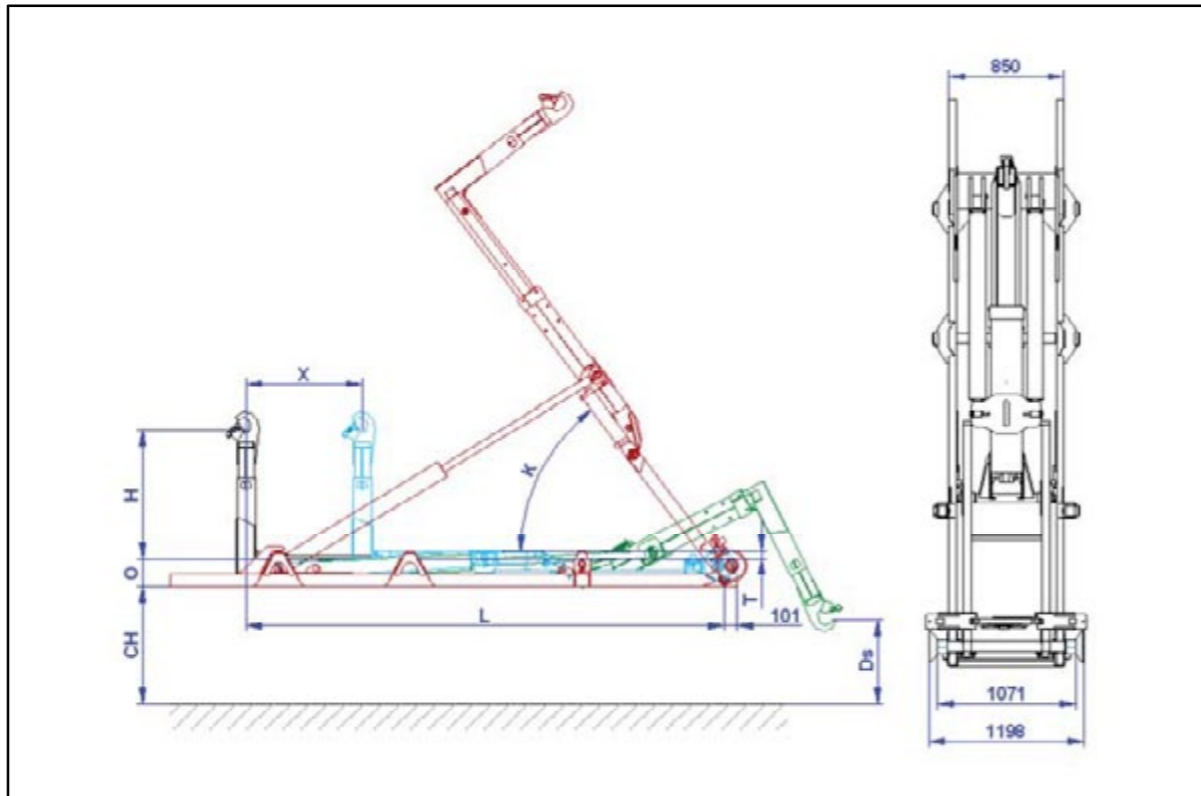

| TYPE: | 6-33-S | 6-45-S |
|----------------------------------|-------------|-----------|
| H (mm) | 900 | 900 |
| X (mm) | 700 | 1100 |
| L (mm) | 3300 | 4500 |
| O (mm) | 220 | 220 |
| K | 50° | 50° |
| R (mm) | 2079 | 2079 |
| T (mm) | 53 | 53 |
| Weight ¹ (kg) | 920 | 1020 |
| DS (mm) | 749 | 798 |
| Min./max. container length (mm) | 2800 - 4300 | 3600-5500 |
| Lifting & Tipping capacity (kg.) | 6000 | 6000 |
| Working pressure (MPa) | 35 | 35 |
| Oil flow l/min. | 35 | 35 |
| Oil tank size l | 40 | 40 |

H = Hook height, CH = Chassis height, DS = Lowest pick up point (depending on hook- and chassis height)

¹ Rough estimation based on a standard system, filled with oil and without mounting kit accessories.

8 TONNE 'CITY' HOOK LOADER – S TYPE

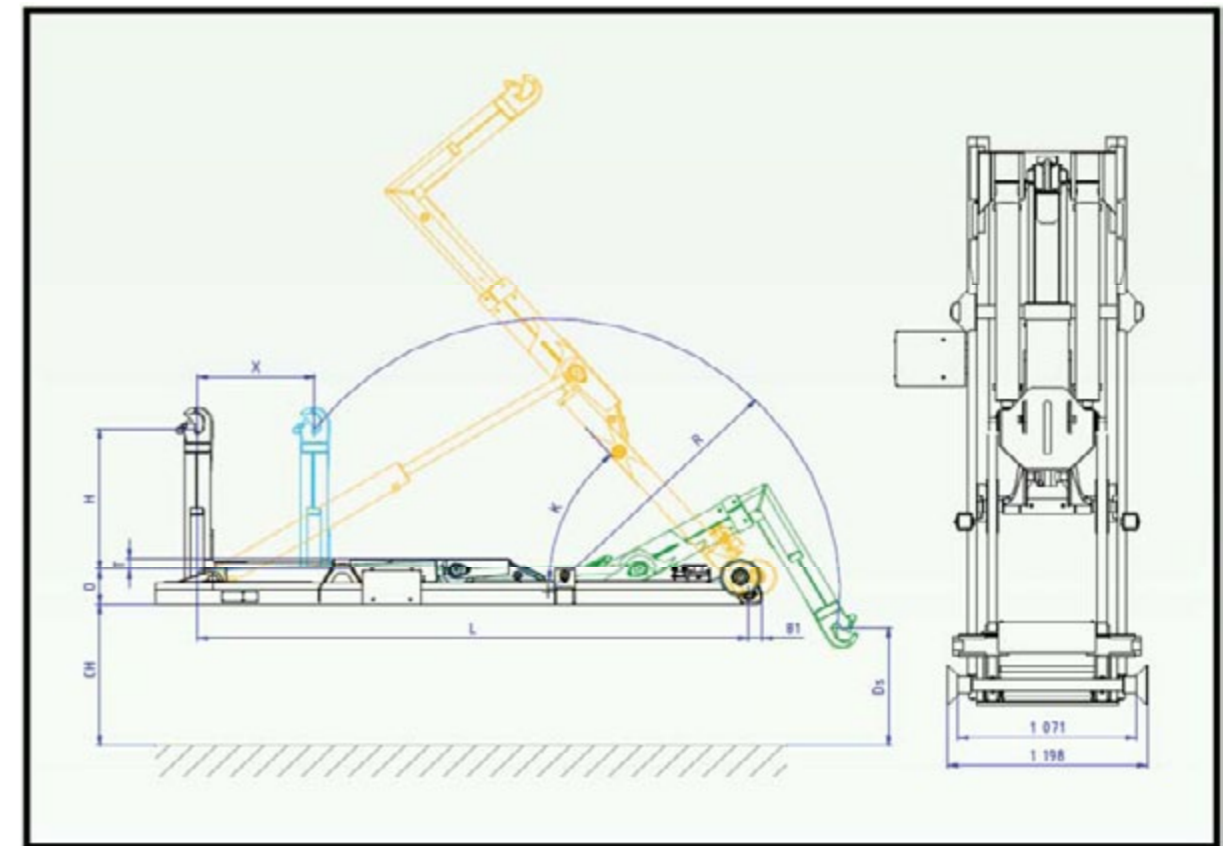

| TECHNICAL INFO | 8-36 S |
|---|-----------|
| Hook Height (mm) | 900 |
| K (°) | 49 |
| T Tunnel Height (mm) | 75 |
| Tunnel width (mm) | 900 |
| R (mm) | 1828 |
| DS (mm) | 749 |
| Min./max. container length (mm) | 3000-4600 |
| System Weight inc operating fluids (kg) | 1114 |

DS = Lowest pick up point (depending on hook- and chassis height)

Pressure & Flow : 64 Litres per minute @ 280 bar

10 TONNE HOOK LOADER – S TYPE

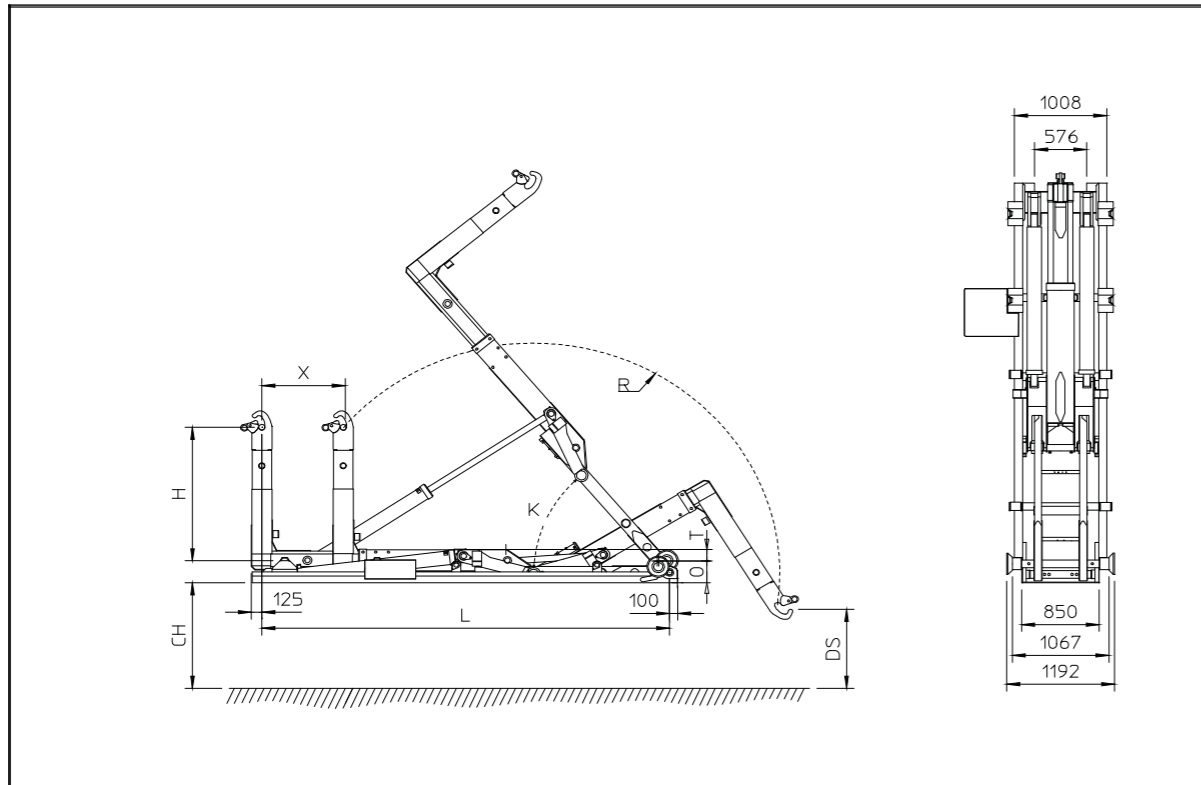

| TYPE: | 10-39-S | 10-42-S | 10-45-S | 10-47-S | 10-49-S | 10-51-S | 10-53-S | 10-55-S | 10-57-S |
|--|-----------|-----------|-----------|-----------|-----------|-----------|-----------|-----------|-----------|
| X (mm) | 800 | 900 | 900 | 1000 | 1000 | 1000 | 1000 | 1200 | 1200 |
| L (mm) | 3900 | 4200 | 4500 | 4700 | 4900 | 5100 | 5350 | 5550 | 5700 |
| O (mm) | 277 | 277 | 277 | 277 | 277 | 277 | 277 | 277 | 277 |
| K | 52° | 50° | 50° | 50° | 48° | 50° | 50° | 50° | 47° |
| R (mm) | 2600 | 2650 | 2725 | 2880 | 2880 | 3045 | 3045 | 3045 | 3045 |
| T (mm) | 130 | 130 | 130 | 130 | 130 | 130 | 130 | 130 | 130 |
| Weight ¹ (kg) | 1750 | 1800 | 1850 | 1930 | 1980 | 2050 | 2080 | 2100 | 2150 |
| DS (mm) | 1070 | 1127 | 950 | 1006 | 1062 | 1167 | 1167 | 1167 | 1167 |
| Min./max. container length (mm) | 3150-5000 | 3350-5300 | 3650-5600 | 3750-5800 | 3950-6000 | 4150-6200 | 4400-6450 | 4400-6650 | 4550-6800 |
| Loading (time) ² (s) | 22 | 23 | 24 | 28 | 28 | 28 | 28 | 29 | 29 |
| Unloading (time) ² (s) | 28 | 29 | 31 | 35 | 35 | 35 | 35 | 36 | 36 |
| Tipping (time) ² (s) | 23 | 23 | 26 | 30 | 30 | 30 | 30 | 30 | 30 |
| Fast unloading (time) ² (s) | 13 | 14 | 14 | 16 | 16 | 16 | 16 | 17 | 17 |

H = Hook height, CH = Chassis height, DS = Lowest pick up point (depending on hook- and chassis height)

¹ Rough estimation based on a standard system, filled with oil and without mounting kit accessories.

² Rough estimation based on PTO type C, pump 60 l/min., motor 1200rpm, PTO transmission i = 1.0 and dependent on cylinder thickness.

16 TONNE HOOK LOADER – S TYPE

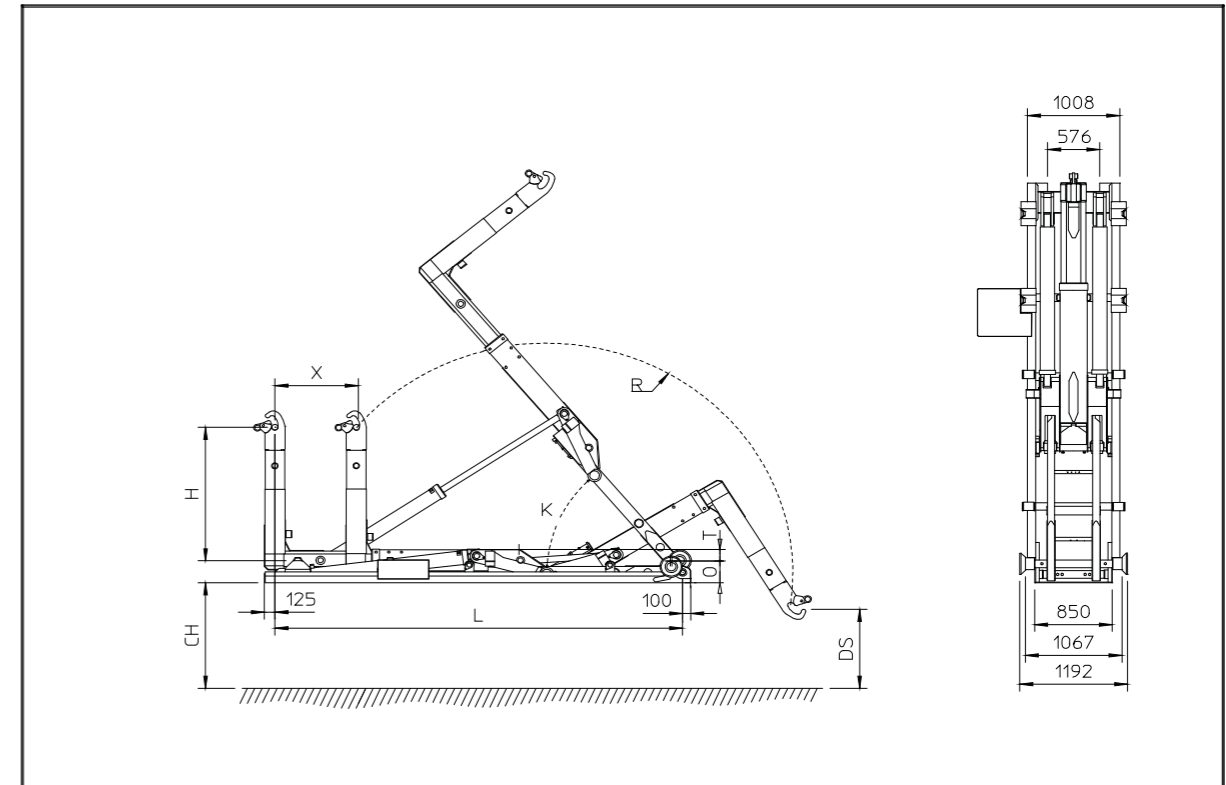

| TYPE: | 16-39-S | 16-42-S | 16-45-S | 16-47-S | 16-49-S | 16-51-S | 16-53-S | 16-55-S | 16-57-S |
|--|-----------|-----------|-----------|-----------|-----------|-----------|-----------|-----------|-----------|
| X (mm) | 800 | 900 | 900 | 1000 | 1000 | 1000 | 1000 | 1200 | 1200 |
| L (mm) | 3900 | 4200 | 4500 | 4700 | 4900 | 5100 | 5350 | 5550 | 5700 |
| O (mm) | 277 | 277 | 277 | 277 | 277 | 277 | 277 | 277 | 277 |
| K | 52° | 50° | 50° | 50° | 48° | 50° | 50° | 50° | 47° |
| R (mm) | 2600 | 2650 | 2725 | 2880 | 2880 | 3045 | 3045 | 3045 | 3045 |
| T (mm) | 130 | 130 | 130 | 130 | 130 | 130 | 130 | 130 | 130 |
| Weight ¹ (kg) | 1750 | 1800 | 1850 | 1930 | 1980 | 2050 | 2080 | 2100 | 2150 |
| DS (mm) | 1070 | 1127 | 950 | 1006 | 1062 | 1167 | 1167 | 1167 | 1167 |
| Min./max. container length (mm) | 3150-5000 | 3350-5300 | 3650-5600 | 3750-5800 | 3950-6000 | 4150-6200 | 4400-6450 | 4400-6650 | 4550-6800 |
| Loading (time) ² (s) | 27 | 28 | 30 | 34 | 34 | 34 | 34 | 38 | 38 |
| Unloading (time) ² (s) | 35 | 35 | 38 | 44 | 44 | 44 | 44 | 45 | 45 |
| Tipping (time) ² (s) | 30 | 30 | 33 | 39 | 39 | 39 | 39 | 39 | 39 |
| Fast unloading (time) ² (s) | 15 | 15 | 16 | 17 | 17 | 17 | 17 | 19 | 19 |

H = Hook height, CH = Chassis height, DS = Lowest pick up point (depending on hook- and chassis height)

¹ Rough estimation based on a standard system, filled with oil and without mounting kit accessories.

² Rough estimation based on PTO type C, pump 60 l/min., motor 1200rpm, PTO transmission i = 1.0 and dependent on cylinder thickness.

20 TONNE HOOK LOADER – S TYPE

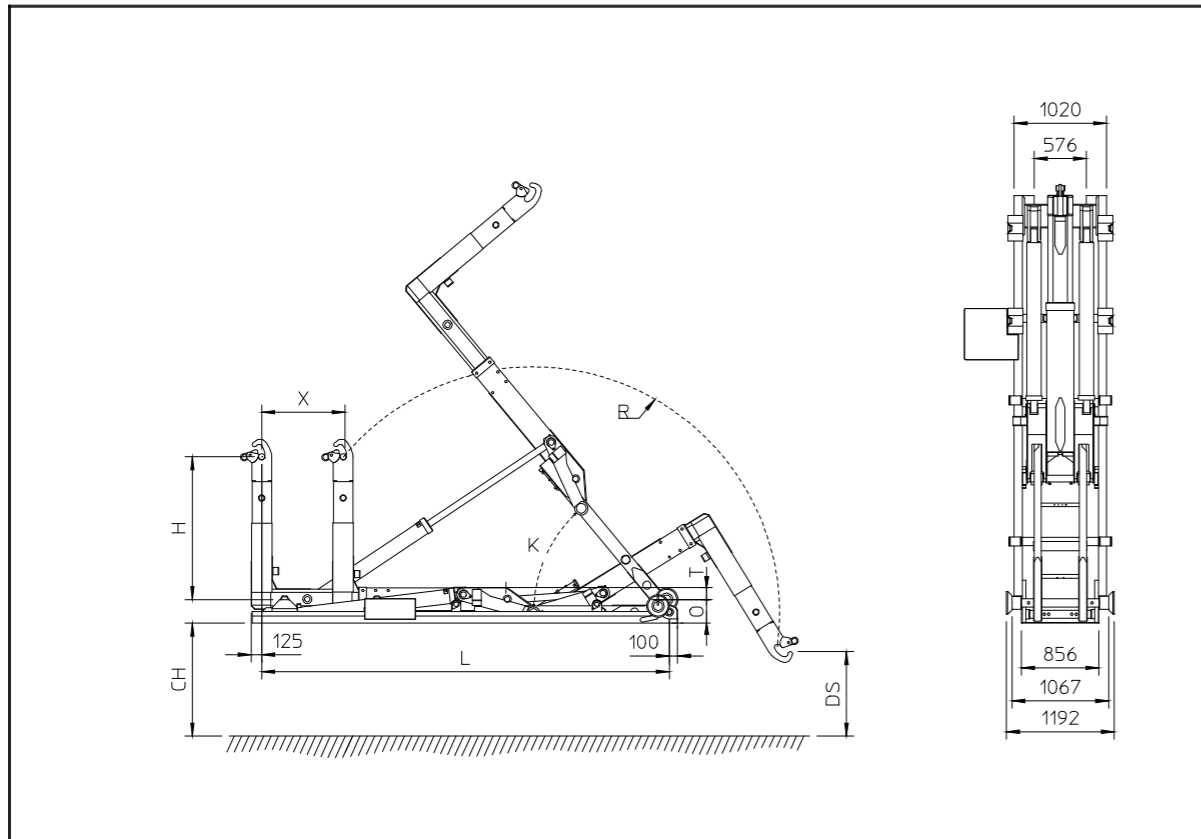

| TYPE: | 20-45-S | 20-47-S | 20-49-S | 20-51-S | 20-53-S | 20-55-S | 20-57-S | 20-58-S | 20-60-S | 20-62-S | 20-65-S | 20-67-S |
|--|-----------|-----------|-----------|-----------|-----------|-----------|-----------|-----------|-----------|-----------|-----------|-----------|
| X (mm) | 900 | 1000 | 1000 | 1000 | 1000 | 1200 | 1200 | 1200 | 1400 | 1400 | 1500 | 1600 |
| L (mm) | 4500 | 4700 | 4900 | 5100 | 5350 | 5550 | 5700 | 5800 | 6000 | 6200 | 6500 | 6700 |
| O (mm) | 280 | 280 | 280 | 280 | 280 | 280 | 280 | 280 | 280 | 280 | 280 | 280 |
| K | 50° | 57° | 53° | 53° | 49° | 49° | 47° | 49° | 49° | 47° | 48° | 48° |
| R (mm) | 2725 | 2880 | 2880 | 3045 | 3045 | 3045 | 3045 | 3125 | 3125 | 3125 | 3340 | 3340 |
| T (mm) | 130 | 130 | 130 | 130 | 130 | 130 | 130 | 130 | 130 | 130 | 130 | 130 |
| Weight ¹ (kg) | 2250 | 2275 | 2300 | 2350 | 2375 | 2450 | 2475 | 2525 | 2550 | 2575 | 2775 | 2800 |
| DS (mm) | 951 | 1054 | 1054 | 1167 | 1167 | 1167 | 1167 | 1120 | 1120 | 1120 | 1137 | 1137 |
| Min./max. container length (mm) | 3650-5600 | 3750-5800 | 3950-6000 | 4200-6200 | 4400-6450 | 4400-6550 | 4550-6800 | 4650-6900 | 4650-7100 | 4850-7300 | 5050-7600 | 5150-7800 |
| Loading (time) ² (s) | 34 | 34 | 34 | 39 | 39 | 40 | 40 | 39 | 40 | 46 | 49 | 56 |
| Unloading (time) ² (s) | 42 | 44 | 44 | 49 | 49 | 50 | 50 | 53 | 54 | 59 | 63 | 71 |
| Tipping (time) ² (s) | 37 | 39 | 39 | 43 | 43 | 43 | 43 | 46 | 46 | 51 | 55 | 61 |
| Fast unloading (time) ² (s) | 17 | 17 | 17 | 19 | 19 | 21 | 21 | 21 | 22 | 22 | 24 | 25 |

H = Hook height, CH = Chassis height, DS = Lowest pick up point (depending on hook- and chassis height)

¹ Rough estimation based on a standard system, filled with oil and without mounting kit accessories.

² Rough estimation based on PTO type C, pump 80 l/min., motor 1200rpm, PTO transmission i = 1.0 and dependent on cylinder thickness.

20 TONNE HOOK LOADER – SK TYPE

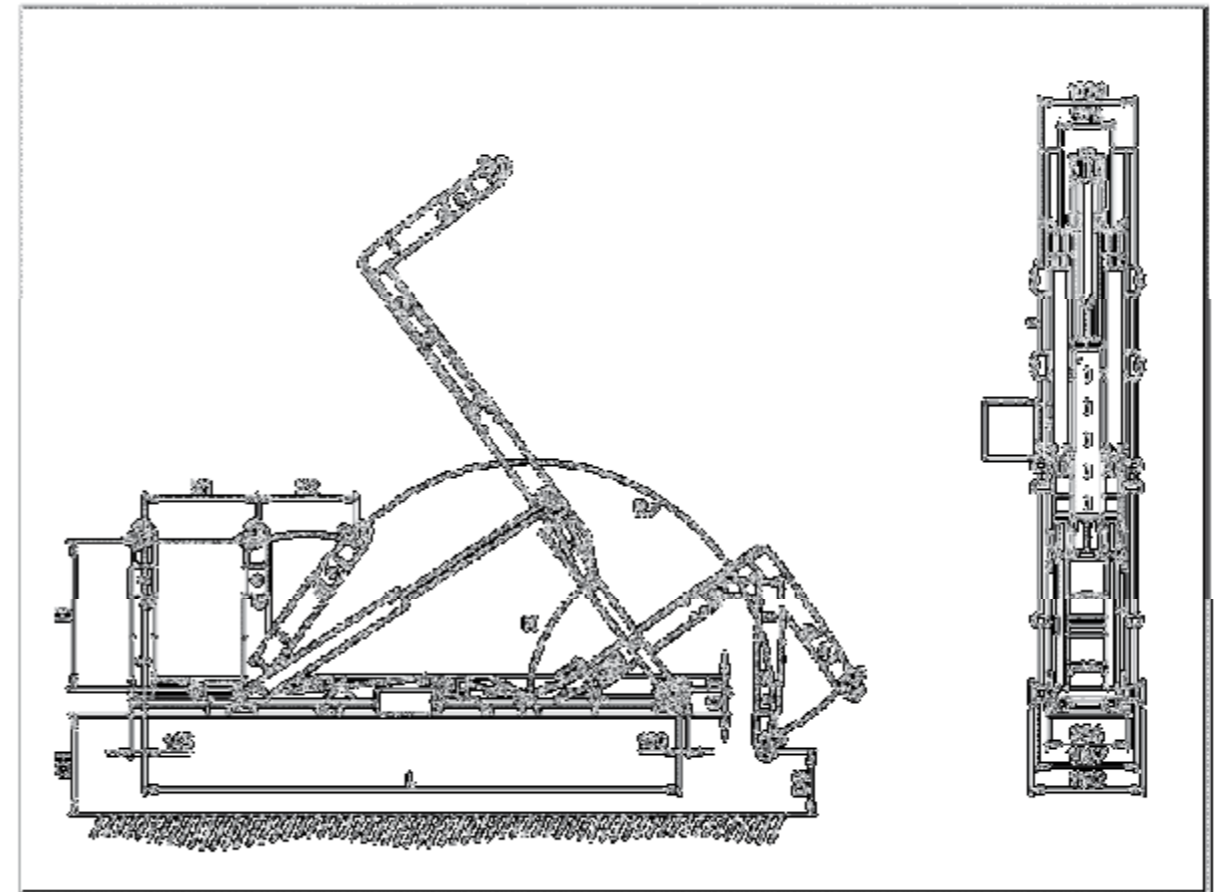

| TYPE: | 20-49-SK | 20-51-SK | 20-53-SK | 20-55-SK | 20-57-SK | 20-58-SK | 20-60-SK | 20-62-SK | 20-65-SK | 20-67-SK |
|--|-----------|-----------|-----------|-----------|-----------|-----------|-----------|-----------|-----------|-----------|
| X (mm) | 800 | 800 | 1000 | 1000 | 1200 | 1300 | 1300 | 1300 | 1300 | 1400 |
| L (mm) | 4900 | 5100 | 5350 | 5550 | 5700 | 5850 | 6000 | 6200 | 6500 | 6700 |
| O (mm) | 280 | 280 | 280 | 280 | 280 | 280 | 280 | 280 | 280 | 280 |
| K | 57° | 53° | 53° | 54° | 54° | 56° | 53° | 50° | 51° | 51° |
| R (mm) | 2310 | 2310 | 2345 | 2495 | 2455 | 2455 | 2495 | 2495 | 2720 | 2720 |
| T (mm) | 130 | 130 | 130 | 130 | 130 | 130 | 130 | 130 | 130 | 130 |
| Weight ¹ (kg) | 2650 | 2700 | 2725 | 2800 | 2825 | 2875 | 2925 | 2975 | 3100 | 3250 |
| DS (mm) | 550 | 550 | 578 | 691 | 662 | 580 | 607 | 607 | 687 | 687 |
| Min./max. container length (mm) | 3050-6000 | 3250-6200 | 3300-6450 | 3300-6650 | 3450-6800 | 3650-6900 | 3650-7100 | 3850-7300 | 4150-7600 | 4350-7800 |
| Loading (time) ² (s) | 38 | 40 | 41 | 41 | 47 | 49 | 49 | 49 | 52 | 59 |
| Unloading (time) ² (s) | 49 | 54 | 55 | 55 | 62 | 65 | 65 | 65 | 68 | 76 |
| Tipping (time) ² (s) | 39 | 43 | 43 | 43 | 49 | 51 | 51 | 51 | 55 | 61 |
| Fast unloading (time) ² (s) | 22 | 24 | 25 | 25 | 27 | 28 | 28 | 28 | 28 | 29 |

H = Hook height, CH = Chassis height, DS = Lowest pick up point (depending on hook- and chassis height)

¹ Rough estimation based on a standard system, filled with oil and without mounting kit accessories.

² Rough estimation based on PTO type C, pump 80 l/min., motor 1200rpm, PTO transmission i = 1.0 and dependent on cylinder thickness.

26 TONNE HOOK LOADER – SK TYPE

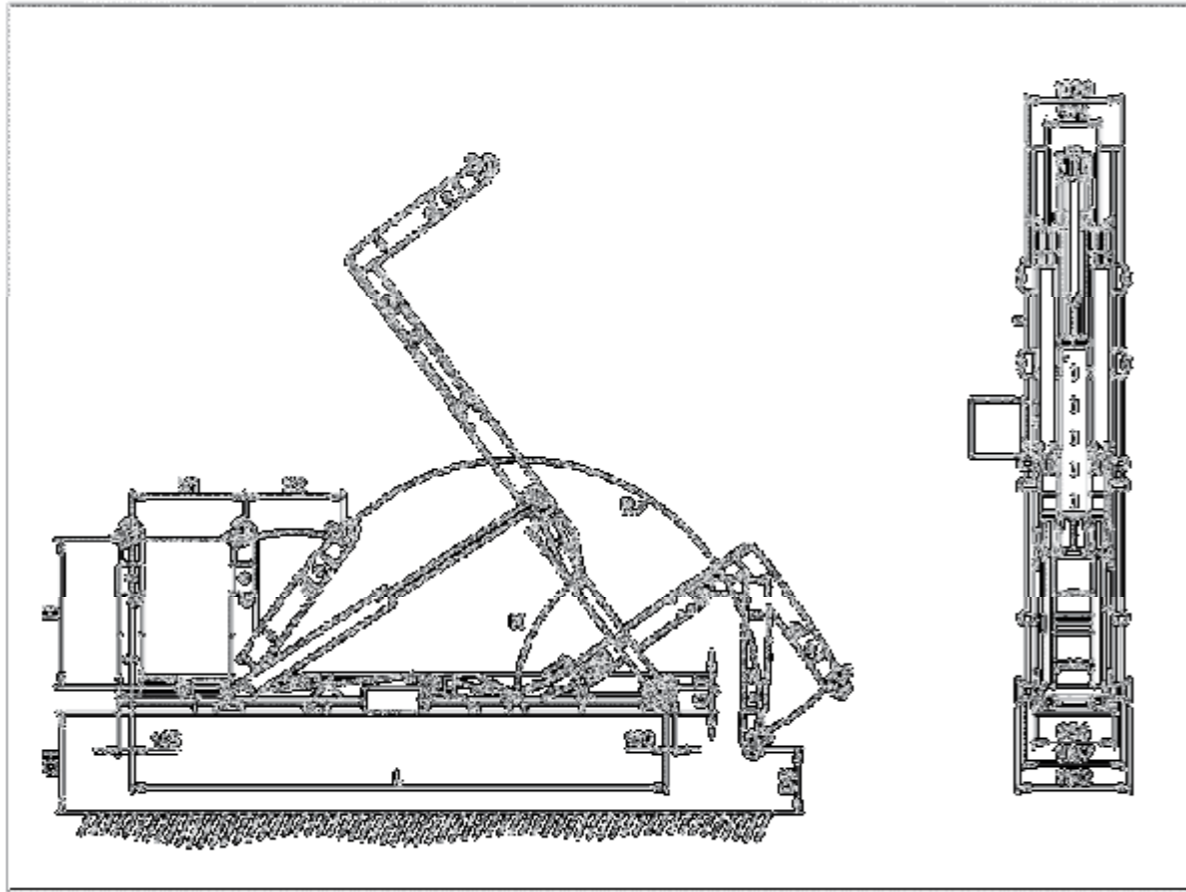

| TYPE: | 26-49-SK | 26-51-SK | 26-53-SK | 26-55-SK | 26-57-SK | 26-58-SK | 26-60-SK | 26-62-SK | 26-65-SK | 26-67-SK |
|--|---------------|---------------|---------------|---------------|---------------|---------------|---------------|---------------|---------------|---------------|
| X (mm) | 800 +1050 | 800 +1050 | 1000 +1050 | 1000 +1050 | 1200 +1050 | 1300 +1050 | 1300 +1050 | 1300 +1050 | 1300 +1050 | 1400 +1050 |
| L (mm) | 4900 | 5100 | 5350 | 5550 | 5700 | 5850 | 6000 | 6200 | 6500 | 6700 |
| O (mm) | 280 | 280 | 280 | 280 | 280 | 280 | 280 | 280 | 280 | 280 |
| K | 57° | 53° | 53° | 54° | 54° | 56° | 53° | 50° | 51° | 51° |
| R (mm) | 2310 | 2310 | 2345 | 2495 | 2455 | 2455 | 2495 | 2495 | 2720 | 2720 |
| T (mm) | 140 | 140 | 140 | 140 | 140 | 140 | 140 | 140 | 140 | 140 |
| Weight ¹ (kg) | 2700 | 2800 | 2850 | 2925 | 2950 | 2975 | 3025 | 3075 | 3200 | 3250 |
| DS (mm) | 550 | 550 | 578 | 691 | 662 | 580 | 607 | 607 | 687 | 687 |
| Min./max. container length (mm) | 3050- 6000 | 3250- 6200 | 3300- 6450 | 3300- 6650 | 3450- 6800 | 3650- 6900 | 3650- 7100 | 3850- 7300 | 4150- 7600 | 4350- 7800 |
| Loading (operating time) ² (s) | 51 | 51 | 52 | 52 | 53 | 55 | 55 | 55 | 58 | 59 |
| Unloading (operating time) ² (s) | 65 | 65 | 66 | 66 | 67 | 71 | 71 | 71 | 75 | 76 |
| Tipping (time) ² (s) | 54 | 54 | 54 | 54 | 54 | 57 | 57 | 57 | 61 | 61 |
| Fast unloading (operating time) ² (s) | 24 | 24 | 25 | 25 | 27 | 28 | 28 | 28 | 28 | 29 |

H = Hook height, CH = Chassis height, DS = Lowest pick up point (depending on hook- and chassis height)

¹ Rough estimation based on a standard system, filled with oil and without mounting kit accessories.

² Rough estimation based on PTO type C, pump 80 l/min., motor 1200rpm, PTO transmission i = 1.0 and dependent on cylinder thickness.



FERRARI
300
Series



RDC

A crane in Your Hand (Optional)

Innovative "Single Hand" radio remote control by Hetriconic

- Transmitter with compact dimensions and minimal weight
- Proportional control
- Single-hand control of every crane function by radio
- Safe stabilizer operation by radio control
- Cable control (optional)
- Transmitter operation with two 'AA' batteries.*



The operator can control the crane with high precision proportional levers in every position and, doing so, can supervise the loading and unloading operations. That means a great time saving and a higher safety.

All FERRARI CORPORATION remote controls have an identification code and are shielded from electromagnetic fields and from external radio signals.



Key selector box



Visual signaling of the load (With limiter)
Digital readout in bar of the load induced pressure



Sectional electro-hydraulic control valve by Bosch Rexroth
Up to 2 extra activations for control of bucket and rotator or winch;
Proportional valve for the regulation of speed;
Manual levers for emergency use.



Receiver



Visual and acoustic warning of 80% + 100% of the nominal capacity
With limiter device.

Electrohydraulic Power Pack



Electrohydraulic power packs allow the installer to use the crane in special locations or where there is no power take-off available.

Worm and gear rotation

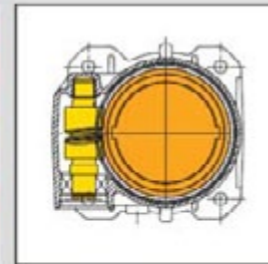

Completely enclosed cast housing with lubrication bath (no 310)

310

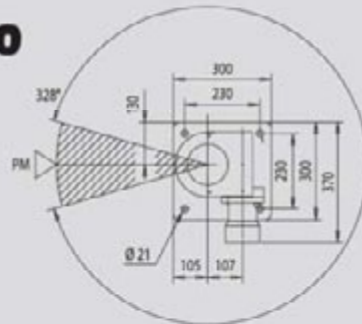

**315
317
322
326**

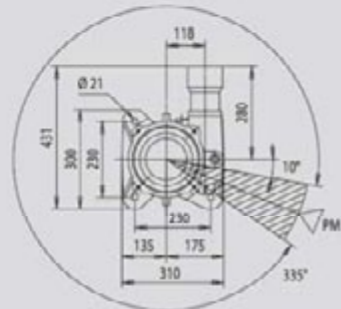

**330
350**

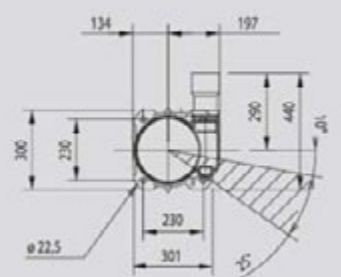

300 series



| MODELS | LIFTING MOMENT | HORIZ. EXTENSION | MAX. REACH LIFTING CAPACITY | SWAYING ANGLE | WEIGHT | PRESSURE | DIMENSIONS WxHxD |
|---------------|----------------|------------------|-----------------------------|---------------|--------|----------|------------------|
| | tm | m | kg | ° | kg | bar | mm |
| 310 A1 | 0.93 | 1.90 | 405 | 320 | 145 | 180 | 595x1240x370 |
| 310 A2 | - | 2.79 | 310 | 320 | 175 | 180 | 647x1240x370 |
| 315 A1 | 1.27 | 1.90 | 465 | 335 | 174 | 160 | 620x1241x430 |
| 315 A2 | - | 2.79 | 435 | 335 | 199 | 160 | 672x1241x430 |
| 317 A1 | 1.42 | 1.90 | 750 | 335 | 174 | 170 | 620x1241x430 |
| 317 A2 | - | 2.79 | 490 | 335 | 199 | 170 | 672x1241x430 |
| 322 A1 | 2.00 | 2.17 | 920 | 335 | 216 | 160 | 695x1487x430 |
| 322 A2 | - | 3.18 | 615 | 335 | 243 | 160 | 695x1487x430 |
| 322 A3 | - | 4.17 | 405 | 335 | 265 | 150 | 668x1521x430 |
| 326 A1 | 2.38 | 2.20 | 1075 | 335 | 217 | 170 | 930x1521x430 |
| 326 A2 | - | 3.20 | 715 | 335 | 252 | 170 | 1000x1521x430 |
| 326 A3 | - | 4.19 | 510 | 335 | 273 | 170 | 1000x1521x430 |
| 330 A1 | 2.75 | 2.26 | 1210 | 335 | 263 | 160 | 730x1587x440 |
| 330 A2 | - | 3.25 | 815 | 335 | 290 | 160 | 753x1587x440 |
| 330 A3 | - | 4.25 | 600 | 335 | 323 | 160 | 753x1587x440 |
| 350 A1 | 3.45 | 2.50 | 1380 | 395 | 305 | 175 | 976x1702x490 |
| 350 A2 | - | 3.64 | 925 | 395 | 339 | 175 | 1040x1702x490 |
| 350 A3 | - | 4.77 | 675 | 395 | 371 | 175 | 1040x1702x490 |
| 350 A4 | - | 5.91 | 520 | 395 | 399 | 175 | 1040x1702x490 |



Ferrari
500 Series



500 Series

Ferrari

Radio remote control

(Optional)



531
540
541
550
551
561 A1- A4
571 A1- A4



561 A3J1
571 A3J1
581



NO CE



CAN-bus CE

The operator can control the crane with high precision proportional levers in every position and, doing so, can supervise the loading and unloading operations. That means a great time saving and a higher safety.

All F.lli FERRARI CORPORATION remote controls have an identification code and are shielded from electromagnetic fields and from external radio signals.

RDC A crane in the Your Hand

Innovative "Single Hand" radio remote control by Metronic

- Transmitter with compact dimensions and minimal weight
- Proportional speed control
- Single-hand control of every crane function by radio
- Safe stabilizer operation by radio control
- Cable control (optional)
- Transmitter operation with two 'AA' batteries.



FUNCTION SELECTION

PROPORTIONAL SPEED CONTROL

Transmitter with compact dimensions and reduced weight

Receiver

Key selector box

Sectional electro-hydraulic control valve by Bosch Rexroth
Up to 2 extra activations for control of bucket and rotator or winch;
Proportional valve for the regulation of speed;
Manual levers for emergency use.

Visual signaling of the load (With limiter)
Digital readout in bar of the load induced pressure

Visual and acoustic warning of 90% + 100% of the nominal capacity
With limiter device.

METRONIC

500 series



- 561 = 4430 mm
- 551 = 4780 mm
- 550 = 4800 mm
- 541 = 4780 mm
- 540 = 4800 mm



RLC

This device shows the load at the hook on a display placed near the controls, making safe the use of the mechanical extensions following the European Standard EN12999. In case of a CE crane with mechanical extensions it is mandatory to mount the RLC device.

(from 550 upward)



| MODELS | LIFTING MOMENT | HORIZ. EXTENSION | MAX. REACH LIFTING CAPACITY | SLEWING ANGLE | WEIGHT | PRESSURE | DIMENSIONS |
|----------|----------------|------------------|-----------------------------|---------------|--------|----------|---------------|
| | tm | m | kg | ° | kg | bar | WxHxD mm |
| 531 A1 | 2.59 | 4.50 | 575 | 370 | 450 | 175 | 1840x1590x490 |
| 531 A2 | - | 5.95 | 485 | 370 | 485 | 175 | 1920x1590x490 |
| 531 A3 | - | 7.35 | 300 | 370 | 515 | 175 | 2000x1590x490 |
| 540 A1 | 3.83 | 5.80 | 725 | 370 | 601 | 215 | 1964x1780x525 |
| 540 A2 | - | 6.45 | 565 | 370 | 636 | 215 | 1964x1780x525 |
| 540 A3 | - | 7.90 | 455 | 370 | 684 | 215 | 2025x1780x520 |
| 541 A1 | 3.98 | 4.98 | 800 | 400 | 640 | 235 | 2110x1730x535 |
| 541 A2 | - | 6.39 | 590 | 400 | 690 | 235 | 2110x1730x535 |
| 541 A3 | - | 7.85 | 440 | 400 | 740 | 235 | 2110x1730x535 |
| 541 A4 | - | 9.31 | 320 | 400 | 785 | 235 | 2110x1730x535 |
| 550 A1 | 4.73 | 5.00 | 945 | 370 | 593 | 250 | 1964x1780x525 |
| 550 A2 | - | 6.45 | 680 | 370 | 636 | 250 | 1964x1780x525 |
| 550 A3 | - | 7.90 | 510 | 370 | 677 | 250 | 2025x1780x520 |
| 551 A1 | 4.84 | 4.87 | 950 | 400 | 640 | 265 | 2110x1730x535 |
| 551 A2 | - | 6.34 | 690 | 400 | 690 | 265 | 2110x1730x535 |
| 551 A3 | - | 7.79 | 510 | 400 | 740 | 265 | 2110x1730x535 |
| 551 A4 | - | 9.25 | 380 | 400 | 785 | 265 | 2110x1730x535 |
| 561 A1 | 6.58 | 5.49 | 1195 | 387 | 880 | 245 | 2285x1960x810 |
| 561 A2 | - | 7.85 | 865 | 387 | 950 | 245 | 2285x1960x810 |
| 561 A3 | - | 8.79 | 645 | 387 | 1080 | 245 | 2285x1960x810 |
| 561 A4 | - | 10.45 | 485 | 387 | 1160 | 245 | 2285x1960x810 |
| 561 A3J1 | - | 12.25 | 295 | 387 | 1190 | 245 | 2285x1960x735 |
| 571 A1 | 7.87 | 5.55 | 1265 | 387 | 880 | 265 | 2310x2000x800 |
| 571 A2 | - | 7.87 | 925 | 387 | 940 | 265 | 2310x2000x800 |
| 571 A3 | - | 8.81 | 695 | 387 | 1020 | 265 | 2310x2000x800 |
| 571 A4 | - | 10.45 | 520 | 387 | 1080 | 265 | 2310x2000x800 |
| 571 A3J1 | - | 12.25 | 345 | 387 | 1200 | 265 | 2310x2000x730 |
| 581 A1 | 7.87 | 5.55 | 1405 | 387 | 910 | 285 | 2310x2000x800 |
| 581 A2 | - | 7.20 | 1030 | 387 | 990 | 285 | 2310x2000x800 |
| 581 A3 | - | 8.81 | 780 | 387 | 1050 | 285 | 2310x2000x800 |
| 581 A4 | - | 10.50 | 590 | 387 | 1180 | 285 | 2310x2000x800 |
| 581 A3J2 | - | 13.75 | 315 | 387 | 1260 | 285 | 2310x2000x730 |

700 Series

700 Series

| MODELS | LIFTING MOMENT | HORIZ. EXTENSION | MAX. REACH LIFTING CAPACITY | SLEWING ANGLE | WEIGHT | PRESSURE | DIMENSIONS |
|----------|----------------|------------------|-----------------------------|---------------|--------|----------|----------------|
| | tm | m | kg | ° | kg | bar | WxHxD mm |
| 710 A1 | 9.94 | 5.73 | 1670 | 403 | 1315 | 250 | 2290x2230x670 |
| 710 A2 | - | 7.62 | 1200 | 403 | 1410 | 250 | 2290x2230x670 |
| 710 A3 | - | 9.51 | 875 | 403 | 1500 | 250 | 2300x2230x670 |
| 710 A4 | - | 11.40 | 610 | 403 | 1590 | 235 | 2300x2230x750 |
| 710 A3J2 | - | 14.41 | 350 | 403 | 1720 | 245 | 2300x2230x820 |
| SC710 A1 | 9.33 | 4.23 | 2230 | 403 | 1200 | 240 | 2290x2230x670 |
| SC710 A2 | - | 6.12 | 1490 | 403 | 1375 | 240 | 2290x2230x670 |
| SC710 A3 | - | 8.00 | 1070 | 403 | 1465 | 240 | 2315x2230x670 |
| SC710 A4 | - | 9.87 | 670 | 403 | 1555 | 240 | 2315x2230x750 |
| 712 A2 | 11.7 | 8.32 | 1250 | 403 | 1700 | 265 | 2490x2280x750 |
| 712 A3 | - | 10.41 | 800 | 403 | 1815 | 265 | 2490x2280x750 |
| 712 A4 | - | 12.54 | 450 | 403 | 1930 | 265 | 2490x2280x750 |
| 712 A5 | - | 14.64 | 470 | 403 | 2015 | 265 | 2490x2280x835 |
| 712 A4J2 | - | 17.53 | 290 | 403 | 2160 | 265 | 2490x2300x940 |
| SC712 A1 | 11.9 | 4.41 | 2715 | 403 | 1465 | 260 | 2500x2280x750 |
| SC712 A2 | - | 6.45 | 1770 | 403 | 1605 | 260 | 2500x2280x750 |
| SC712 A3 | - | 8.53 | 1235 | 403 | 1720 | 255 | 2500x2280x750 |
| SC712 A4 | - | 10.67 | 875 | 403 | 1835 | 250 | 2500x2280x750 |
| SC712 A5 | - | 12.76 | 580 | 403 | 1920 | 235 | 2500x2280x835 |
| 714 A1 | 14.0 | 6.29 | 2215 | 403 | 1560 | 295 | 2490x2280x750 |
| 714 A2 | - | 8.33 | 1540 | 403 | 1700 | 295 | 2490x2280x750 |
| 714 A3 | - | 10.41 | 1140 | 403 | 1815 | 295 | 2490x2280x750 |
| 714 A4 | - | 12.55 | 850 | 403 | 1930 | 295 | 2490x2280x750 |
| 714 A5 | - | 14.64 | 640 | 403 | 2015 | 305 | 2490x2280x835 |
| 714 A4J2 | - | 17.47 | 355 | 403 | 2160 | 305 | 2490x2300x940 |
| 717 A1 | 15.3 | 6.20 | 2475 | 400 | 2070 | 290 | 2500x2300x915 |
| 717 A2 | - | 8.25 | 1715 | 400 | 2215 | 290 | 2500x2300x915 |
| 717 A3 | - | 10.29 | 1240 | 400 | 2350 | 290 | 2500x2300x915 |
| 717 A4 | - | 12.38 | 920 | 400 | 2475 | 290 | 2500x2300x915 |
| 717 A5 | - | 14.52 | 680 | 400 | 2585 | 290 | 2500x2300x1020 |
| 717 A6 | - | 16.60 | 510 | 400 | 2675 | 290 | 2500x2300x1020 |
| 717 A3J3 | - | 17.76 | 390 | 400 | 2810 | 290 | 2500x2400x1100 |
| 717 A4J2 | - | 18.10 | 320 | 400 | 2890 | 290 | 2510x2450x1100 |
| 717 A4J3 | - | 19.86 | 240 | 400 | 2945 | 290 | 2510x2450x1100 |
| 719 A1 | 16.0 | 6.20 | 2575 | 400 | 2070 | 310 | 2500x2300x915 |
| 719 A2 | - | 8.25 | 1800 | 400 | 2215 | 310 | 2500x2300x915 |
| 719 A3 | - | 10.29 | 1310 | 400 | 2350 | 310 | 2500x2300x915 |
| 719 A4 | - | 12.38 | 980 | 400 | 2475 | 310 | 2500x2300x915 |
| 719 A5 | - | 14.52 | 730 | 400 | 2585 | 310 | 2500x2300x1020 |
| 719 A6 | - | 16.60 | 555 | 400 | 2675 | 310 | 2500x2300x1020 |
| 719 A3J3 | - | 17.76 | 445 | 400 | 2810 | 310 | 2500x2400x1100 |
| 719 A4J2 | - | 18.10 | 365 | 400 | 2890 | 310 | 2510x2450x1100 |
| 719 A4J3 | - | 19.86 | 280 | 400 | 2945 | 310 | 2510x2450x1100 |
| 721 A1 | 19.2 | 6.40 | 3000 | 400 | 2450 | 290 | 2520x2300x1040 |
| 721 A2 | - | 8.31 | 2150 | 400 | 2600 | 290 | 2520x2300x1040 |
| 721 A3 | - | 10.29 | 1600 | 400 | 2750 | 290 | 2520x2300x1040 |
| 721 A4 | - | 12.22 | 1220 | 400 | 2890 | 290 | 2520x2300x1040 |
| 721 A5 | - | 14.31 | 925 | 400 | 3010 | 290 | 2520x2300x1040 |
| 721 A6 | - | 16.40 | 700 | 400 | 3130 | 290 | 2520x2300x1040 |
| 721 A7 | - | 18.50 | 520 | 400 | 3230 | 290 | 2520x2300x1100 |
| 721 A8 | - | 20.40 | 375 | 400 | 3320 | 290 | 2520x2300x1100 |
| 721 A4J3 | - | 20.40 | 300 | 400 | 3490 | 290 | 2520x2545x1150 |
| 721 A6J2 | - | 21.95 | 305 | 400 | 3430 | 290 | 2520x2450x1150 |
| SC721 A2 | 19.0 | 6.41 | 2880 | 400 | 2550 | 290 | 2520x2300x1035 |
| SC721 A3 | - | 8.39 | 2070 | 400 | 2700 | 290 | 2520x2300x1035 |
| SC721 A4 | - | 10.33 | 1545 | 400 | 2815 | 290 | 2520x2300x1035 |
| SC721 A5 | - | 12.41 | 1170 | 400 | 2960 | 290 | 2520x2300x1035 |
| SC721 A6 | - | 14.50 | 900 | 400 | 3060 | 290 | 2520x2300x1035 |
| 723 A1 | 19.8 | 6.40 | 3180 | 400 | 2450 | 300 | 2520x2300x1040 |
| 723 A2 | - | 8.31 | 2250 | 400 | 2600 | 300 | 2520x2300x1040 |
| 723 A3 | - | 10.29 | 1685 | 400 | 2750 | 300 | 2520x2300x1040 |
| 723 A4 | - | 12.22 | 1300 | 400 | 2890 | 300 | 2520x2300x1040 |
| 723 A5 | - | 14.31 | 995 | 400 | 3010 | 300 | 2520x2300x1040 |
| 723 A6 | - | 16.40 | 760 | 400 | 3130 | 300 | 2520x2300x1040 |
| 723 A7 | - | 18.50 | 565 | 400 | 3230 | 300 | 2520x2300x1100 |
| 723 A8 | - | 20.40 | 405 | 400 | 3320 | 300 | 2520x2300x1100 |
| 723 A4J3 | - | 20.40 | 325 | 400 | 3490 | 300 | 2520x2545x1150 |
| 723 A6J2 | - | 21.95 | 330 | 400 | 3430 | 300 | 2520x2450x1150 |
| SC723 A2 | 19.3 | 6.41 | 2975 | 400 | 2550 | 300 | 2520x2300x1035 |
| SC723 A3 | - | 8.39 | 2150 | 400 | 2700 | 300 | 2520x2300x1035 |
| SC723 A4 | - | 10.33 | 1620 | 400 | 2815 | 300 | 2520x2300x1035 |
| SC723 A5 | - | 12.41 | 1240 | 400 | 2960 | 300 | 2520x2300x1035 |
| SC723 A6 | - | 14.50 | 965 | 400 | 3060 | 300 | 2520x2300x1035 |



This device shows the load at the hook on a display placed near the controls, making safe the use of the mechanical extensions following the European Standard EN12999. In case of a CE crane with mechanical extensions it is mandatory to mount the RLC device.

RADIO REMOTE CONTROL (R Version)



The operator can control the crane with high precision proportional levers in every position and, doing so, can supervise the loading and unloading operations. That means a great time saving and higher safety.



All Fjli FERRARI CORPORATION remote controls have an identification code and are shielded from electromagnetic fields and from external radio signals.

ECM4



(Radiocontrol)



(Radiocontrol)



700 Series



RED POWER, TWICE THE POWER*

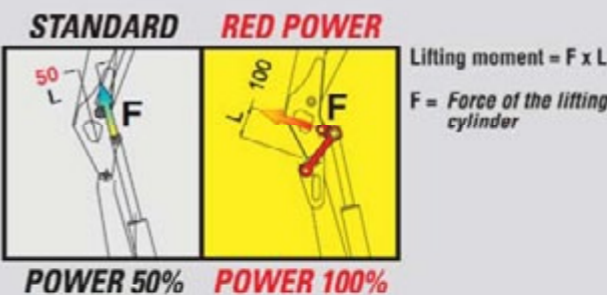

*"Red Power" means more leverage to the crane booms. This leverage is achieved through an articulating connecting rod system.



RED POWER

| MODELS | LIFTING MOMENT | HORIZ. EXTENSION | MAX. REACH LIFTING CAPACITY | SLEWING ANGLE | WEIGHT | PRESSURE | DIMENSIONS |
|----------|----------------|------------------|-----------------------------|---------------|--------|----------|---------------|
| | tm | m | kg | ° | kg | bar | WxHxD mm |
| 726 A1 | 21.4 | 6.40 | 3345 | 400 | 2620 | 325 | 2520x2390x805 |
| 726 A2 | - | 8.31 | 2510 | 400 | 2770 | 325 | 2520x2390x805 |
| 726 A3 | - | 10.29 | 1915 | 400 | 2920 | 325 | 2520x2390x820 |
| 726 A4 | - | 12.22 | 1490 | 400 | 3040 | 325 | 2520x2390x820 |
| 726 A5 | - | 14.31 | 1160 | 400 | 3200 | 325 | 2520x2390x820 |
| 726 A6 | - | 16.40 | 890 | 400 | 3290 | 325 | 2520x2390x820 |
| 726 A7 | - | 18.50 | 640 | 400 | 3410 | 325 | 2520x2390x820 |
| 726 A8 | - | 20.40 | 495 | 400 | 3500 | 325 | 2520x2390x820 |
| 726 A4J2 | - | 21.95 | 495 | 400 | 3570 | 325 | 2520x2470x840 |
| 726 A4J3 | - | 20.40 | 372 | 400 | 3660 | 325 | 2520x2470x840 |
| 726 A6J2 | - | 21.95 | 485 | 400 | 3650 | 325 | 2520x2470x840 |
| SC726 A2 | 20.3 | 6.51 | 3120 | 400 | 2700 | 325 | 2520x2390x805 |
| SC726 A3 | - | 8.49 | 2300 | 400 | 2850 | 325 | 2520x2390x820 |
| SC726 A4 | - | 10.42 | 1750 | 400 | 2990 | 325 | 2520x2390x820 |
| SC726 A5 | - | 12.51 | 1350 | 400 | 3110 | 325 | 2520x2390x820 |
| SC726 A6 | - | 14.60 | 1000 | 400 | 3230 | 325 | 2520x2390x820 |
| 729 A2 | 27.3 | 8.15 | 3225 | 425 | 3305 | 325 | 2500x2360x870 |
| 729 A3 | - | 10.15 | 2440 | 425 | 3445 | 325 | 2500x2360x870 |
| 729 A4 | - | 12.10 | 1905 | 425 | 3620 | 325 | 2500x2360x870 |
| 729 A5 | - | 14.20 | 1485 | 425 | 3760 | 325 | 2500x2360x870 |
| 729 A6 | - | 16.47 | 1160 | 425 | 3885 | 325 | 2500x2360x870 |
| 729 A7 | - | 18.76 | 900 | 425 | 4000 | 325 | 2500x2360x870 |
| 729 A8 | - | 21.04 | 710 | 425 | 4100 | 325 | 2500x2360x870 |
| 729 A6J4 | - | 22.50 | 320 | 425 | 4435 | 325 | 2500x2710x840 |
| 732 A1 | 31.2 | 5.85 | 5340 | 397 | 3590 | 300 | 2500x2355x870 |
| 732 A2 | - | 7.70 | 3850 | 397 | 3820 | 300 | 2500x2355x870 |
| 732 A3 | - | 9.70 | 2870 | 397 | 4040 | 300 | 2500x2355x870 |
| 732 A4 | - | 11.80 | 2180 | 397 | 4270 | 300 | 2500x2355x870 |
| 732 A5 | - | 14.00 | 1670 | 397 | 4440 | 300 | 2500x2355x870 |
| 732 A6 | - | 16.40 | 1290 | 397 | 4600 | 300 | 2500x2405x870 |
| 732 A7 | - | 18.75 | 1000 | 397 | 4720 | 300 | 2500x2405x870 |
| 732 A8 | - | 21.05 | 790 | 397 | 4840 | 300 | 2500x2405x870 |
| 732 A4J4 | - | 21.70 | 605 | 397 | 5110 | 290 | 2515x2620x830 |
| 732 A5J4 | - | 23.90 | 425 | 397 | 5200 | 290 | 2515x2620x830 |
| SC732 A2 | 30.3 | 6.21 | 4875 | 397 | 3820 | 300 | 2500x2355x870 |
| SC732 A3 | - | 8.22 | 3540 | 397 | 4040 | 300 | 2500x2355x870 |
| SC732 A4 | - | 10.30 | 2625 | 397 | 4270 | 300 | 2500x2355x870 |
| SC732 A5 | - | 12.40 | 2015 | 397 | 4440 | 300 | 2500x2355x870 |
| SC732 A6 | - | 14.90 | 1550 | 397 | 4600 | 300 | 2500x2405x870 |
| SC732 A7 | - | 17.20 | 1155 | 397 | 4720 | 300 | 2500x2405x870 |
| SC732 A8 | - | 19.50 | 800 | 397 | 4840 | 300 | 2500x2405x870 |
| 736 A1 | 32.4 | 5.85 | 5340 | 397 | 3590 | 310 | 2500x2355x870 |
| 736 A2 | - | 7.70 | 4020 | 397 | 3820 | 310 | 2500x2355x870 |
| 736 A3 | - | 9.70 | 3040 | 397 | 4040 | 310 | 2500x2355x870 |
| 736 A4 | - | 11.80 | 2340 | 397 | 4270 | 310 | 2500x2355x870 |
| 736 A5 | - | 14.00 | 1810 | 397 | 4440 | 310 | 2500x2355x870 |
| 736 A6 | - | 16.40 | 1420 | 397 | 4600 | 310 | 2500x2405x870 |
| 736 A7 | - | 18.75 | 1120 | 397 | 4720 | 310 | 2500x2405x870 |
| 736 A8 | - | 21.05 | 890 | 397 | 4840 | 310 | 2500x2405x870 |
| 736 A4J4 | - | 21.70 | 705 | 397 | 5110 | 310 | 2515x2620x830 |
| 736 A5J4 | - | 23.90 | 475 | 397 | 5200 | 310 | 2515x2620x830 |
| SC736 A2 | 31.0 | 6.21 | 5060 | 397 | 3820 | 310 | 2500x2355x870 |
| SC736 A3 | - | 8.22 | 3710 | 397 | 4040 | 310 | 2500x2355x870 |
| SC736 A4 | - | 10.30 | 2775 | 397 | 4270 | 310 | 2500x2355x870 |
| SC736 A5 | - | 12.40 | 2165 | 397 | 4440 | 310 | 2500x2355x870 |
| SC736 A6 | - | 14.90 | 1680 | 397 | 4600 | 3 | |

GRABS AND ROTATORS ATTACHMENTS FOR TRUCK MOUNTED CRANE



Brick Stack Grapple
H 332



Pallet Fork
H 415



Orange Peel Grapple
H 650



Clamshell Bucket
H 604HPX



Small Volume Clamshell Bucket
H 626HPX



Clamshell Bucket with Open Shells
H 604U HPX



Rock Grapple
H 613HPX



Timber Grapple
H 632HPX



Hay and Forestry Grapple
H 641HPX



Universal Grapple for Z-Cranes
H 930



Pole Grapple
H 930-1000 Special



Special Grapple for Barrels
H 930 F



Our location In Thornton NSW Offers:

- An extensive range of products
- Customer oriented counselling for original equipment
- Short delivery times through high storage capacities
- Professional workshop operation
- High standards of quality through years of operation
- Fully equipped service centre and machine workshop



About Hyva Group



Hyva Group is a leading global provider of innovative and highly efficient transport solutions for the commercial vehicle and environmental service industries. The company is committed to the development, production, marketing and distribution of components used in hydraulic loading and unloading systems on trucks and trailers. Its products are used worldwide across a range of sectors including transport, construction, mining, materials handling and environmental services providers.

Hyva produces the strongest front end hydraulic telescopic cylinder in the world, double acting cylinders, mobile and static compactors and waste collection units. Hyva's portfolio comprises: Hydraulics (cylinders and tipping gear), Container Handling Systems (hook and skip loaders), Floors (horizontal unloading/loading floors) and Cranes (fixed and rolling). These products are designed and marketed under several well respected brands: Hyva, Kennis, F.Ili Ferrari and AmcoVeba. Hyva is also a distributor of high value components.

Founded in 1979 in The Netherlands, Hyva has significant manufacturing facilities in Brazil, China, Germany, India, Italy and The Netherlands. Operating in more than 130 countries the company has more than 2,400 employees around the world, encompassing 36 subsidiaries and 13 production facilities. Hyva has more than 25,000 customers.



HYVA Pacific Pty Ltd
72 Glenwood Drive
Thornton, NSW. 2322
www.hyva.com
Tel: 1800 041 733
Tel: 02 4966 3777
Fax: 024966 3144

